

DALI PHANTOM M

WHITE PAPER

DEC 2022

M-250

M-375

M-675



DALI

IN ADMIRATION OF MUSIC

A long story in short

Built on experience from the highly acclaimed DALI PHANTOM S-Series, DALI proudly presents the slimline PHANTOM M-Series in-wall speakers.

DALI PHANTOM M-SERIES

The DALI PHANTOM M-Series is slim and versatile and comprises DALI PHANTOM M-250, the more advanced DALI PHANTOM M-375, and, perfect for generous spaces and more ambitious audio systems, the M-675.

M-SERIES SOUND

The DALI PHANTOM M-Series creates spacious and involving sound, regardless of whether you listen actively or passively. And as with all DALI speakers, the PHANTOM M-Series offers DALI's signature wide dispersion for room-filling sound.

M-SERIES ENCLOSURES

The two smaller DALI PHANTOM M-Series models, the M-250 and M-375, share common dimensions of 250 mm width, 775 mm height and just 100 mm depth, while the larger M-675 shares the same depth and width but adds a further 545 mm to the height. The enclosure for all three models is constructed from structural, glass filled ABS combined with a wood composite front panel. The result is hugely rigid and almost completely inert.

M-SERIES BASS/MIDRANGE DRIVERS

The DALI PHANTOM M-250 incorporates two 5 inch bass drivers working with two generously flared bass reflex ports in the front baffle.

The DALI PHANTOM M-375 integrates a larger, 7 inch bass driver matched with two 7 inch passive radiators.

The DALI PHANTOM M-675 expands on the M-375 to integrate two 7 inch bass drivers matched with four 7 inch passive radiators.



DALI PHANTOM M-675



DALI PHANTOM M-375



DALI PHANTOM M-250

A long story in short

M-SERIES TWEETERS

The DALI PHANTOM M-250 incorporates a DALI 28mm soft dome tweeter, while the M-375 and M-675 both feature a state-of-the-art DALI hybrid soft dome and ribbon tweeter.

M-SERIES CROSSOVERS

All three DALI PHANTOM M-Series models benefit from advanced crossover design and techniques that ensure optimal driver integration and wide dispersion.

M-SERIES MOTOR SYSTEM AND SMC

The PHANTOM M-250 bass/midrange driver features a 4-layer 25 mm diameter voice-coil with an iron/SMC composite pole-piece. The M-375 and M-675 bass/midrange drivers incorporates a larger 38 mm diameter voice-coil and a pure SMC pole-piece.

Employing SMC in DALI drivers minimises hysteresis losses and distortion, and results in a more satisfying and enjoyable musical experience.

M-SERIES INSTALLATION

The DALI PHANTOM M-Series is perfect for both stereo and multi-channel systems. Drywall installation requires only 10 cm aperture depth, however installation using accessory on-wall frames is also possible.

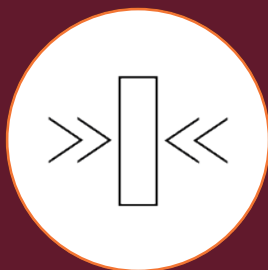

Slim

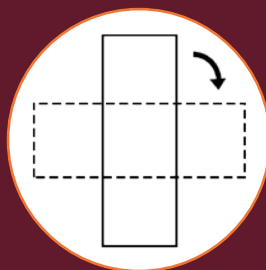

Versatile (LCR)



Easy installation



Wide Dispersion

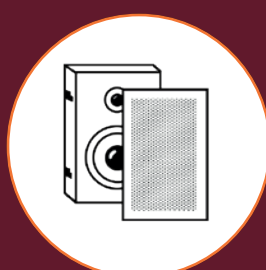

Integrated backbox

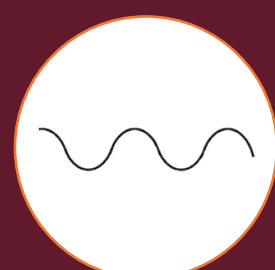

Authentic DALI sound

DALI PHANTOM M-Series

The DALI PHANTOM M-Series comprises three high performance models, all versatile, slim and flexible in application.

All three M-Series models were developed with multi-channel applications in mind, and can be mounted in either portrait or landscape orientation. And all three models are equally suited to front, centre or surround channel roles.

Additionally, as all three models express DALI's long-standing speaker design principles, they can also work perfectly in a custom installed conventional stereo hi-fi system.

DALI PHANTOM M-250

The M-250 utilises two relatively compact bass/ midrange drivers, loaded by twin port reflex ports and integrated with a high performance soft dome tweeter.



5 inch
bass/midrange driver

Soft dome tweeter

5 inch
bass/midrange driver

DALI PHANTOM M-375

The M-375 is configured with a larger bass/ midrange driver matched with two passive radiators and integrated with a hybrid soft dome and a ribbon tweeter.



7 inch
passive radiator

7 inch
bass/midrange driver

Soft dome tweeter

Ribbon tweeter

7 inch
passive radiator



7 inch
passive radiator

7 inch
bass/midrange
driver

Soft dome tweeter

Ribbon tweeter

7 inch
bass/midrange
driver

7 inch
passive radiator

DALI PHANTOM M-675

The M-675 employs two bass/midrange drivers related to the M-375 but upgraded with enhanced surround and voice-coil components. They are matched with four passive radiators in a larger enclosure. Like the M-375, the M-675 utilises DALI's unique hybrid soft dome and ribbon tweeter.

All three DALI PHANTOM M-Series models employ a similar enclosure construction of structural glass reinforced ABS combined with rigid 21 mm thick MDF front panels. Complex internal bracing helps ensure immense mechanical rigidity.

A useful benefit of the common enclosure dimensions of the M-275 and M-375 is that they also share wall aperture and on-wall frame dimensions. This means that customers can try both models in their homes and systems before deciding on which model is the best option.

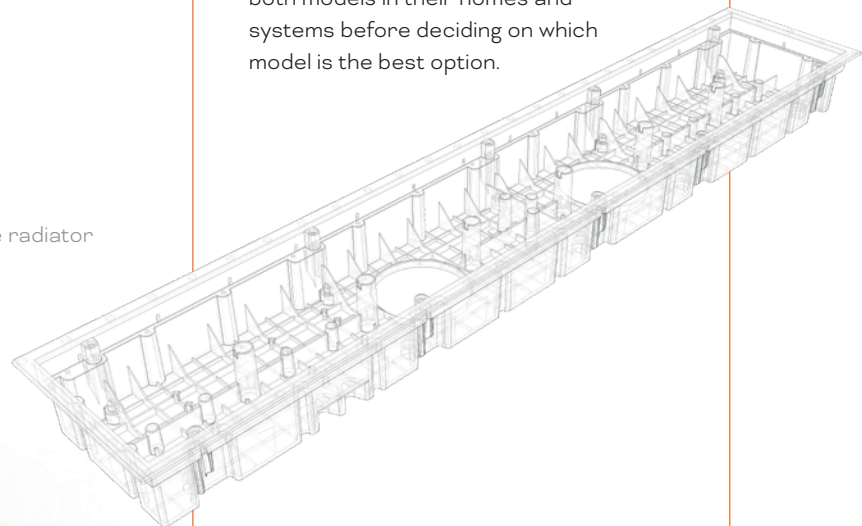

Spacious sound

Listening to music can be either an active or a passive activity.

Active listening is when you sit in front of a speaker and focus on the composition, meaning and details of the music. Passive listening takes place typically whilst socialising, relaxing or perhaps working, with music playing in the background to create an atmosphere.

There is a tendency in many homes to use a single-point speaker, chosen for convenient domestic integration, as the primary source of music. However, a single-point speaker often needs to be fairly loud in order to be heard throughout a room. And during passive listening, high volumes can easily become intrusive, degrading the audio experience and preventing conversation.

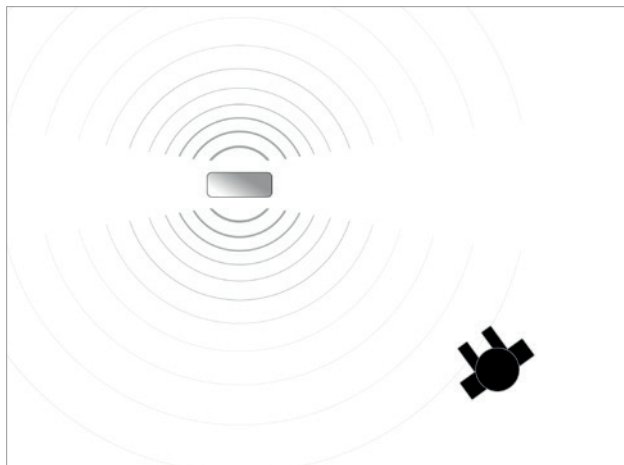

A single-point speaker with blurred sound intensity, during passive listening.

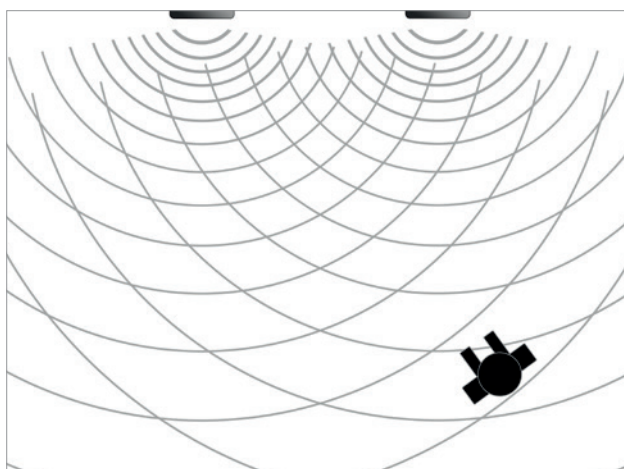

Two speakers provide a stereo perspective, making the music clearer and more detailed. The improved distribution of sound means less volume is required, making conversation easier.

In comparison, multi-speaker systems (stereo or home theatre) provide spacious, room-filling sound more suited to passive listening, due to the speakers more evenly distributing acoustic energy throughout the room. Floor standing or stand mounted speakers can be a great solution, however they may not be suitable for every home. So at DALI, we have set out to provide custom installation solutions that offer authentic DALI performance without taking up interior space.

Following the success of the award-winning DALI PHANTOM S-Series, we decided to build on its legacy. The resulting PHANTOM M-Series offers spacious, detailed and musical audio from remarkably slim in-wall and wall mount enclosures.

Wide dispersion

By specifically designing our drivers for wide dispersion they deliver a smooth and well dispersed sound, making them easy to integrate into any room.

This technology works particularly well with the DALI PHANTOM M-Series as they are mounted flush against the wall. Off-axis optimisation creates a larger sweet spot and perfect sound stage for the listener. It also enables high quality sound from outside the sweet spot for passive listening.

By optimising the audio signal for off-axis listening, both the signal directly reaching the ear and the signal reflected from room surfaces, will convey the same high quality.



DALI's wide dispersion technology fills every corner of the room with in high quality audio and allows the listener to experience the music even if not placed ideally in the sweet spot.

PHANTOM M enclosure

The two smaller DALI PHANTOM M-Series models, the M-250 and M-375, share common dimensions of 250 mm width, 775 mm height and just 100 mm depth, while the larger M-675 shares the same depth and width but adds a further 545 mm to the height to reach 1320 mm.

The PHANTOM M-Series enclosures are incredibly slim for in-wall hi-fi speakers. However, the enclosure engineering requirements to achieve the slim dimensions presented our designers with significant challenges.

To achieve the interior enclosure volume required for low frequency reproduction within the dimensional limitations, the design team designed a 3D Matrix Enclosure in a glass-reinforced ABS compound with a 21 mm thick front panel. Extensive design analysis and testing was applied to optimise both the ABS compound and the dimensions of the 3D Matrix housing.

In order to reduce mechanical vibrations and to benefit midrange and high frequency performance, M-Series enclosures are extensively reinforced internally using MDF brace panels.

The M-Series front panels and bezels carry a matt black finish with no distracting reflective detailing. This helps enable visual integration in home theatre installations by preventing reflections from the projector. M-Series front grilles are magnetically secured, and fully paintable.

A rubber gasket fitted on the rear of the enclosure front bezel both seals the speaker against the wall and minimises the possibility of buzzing.

The integrated terminals are spring-loaded for reliable, durable, and easy connection, and can accommodate cables up to 4.5 mm thick (3.0 mm/AWG 12 is recommended in normal situations).

Six dogleg clamps are integrated in M-Series enclosures. These high performance clamps ensuring secure and tight installation that minimises the risk of buzzing or rattling. The clamps are spring-loaded for ease of use and have a reversible action for gripping extra thick walls – up to 70mm.

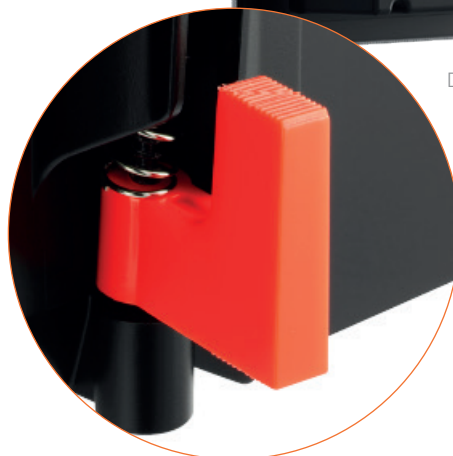

Dogleg used for securing PHANTOM M-Series.

The design of the enclosure benefited from extensive 3D computer modelling and optimisation to ensure maximum strength in combination with minimum resonance.



Bass/midrange drivers

Like all DALI drivers dedicated to reproducing the low frequency and delicate midrange bands, the PHANTOM M-Series bass/midrange drivers feature wood fibre diaphragms.

The PHANTOM M-250 is equipped with twin 5 inch bass/midrange drivers and two reflex ports, whereas the DALI PHANTOM M-375 and M-675 feature 7 inch bass/midrange drivers combined with multiple 7 inch passive radiators – two in the case of the M-375 and four in the case of the M-675.

The bass/midrange drivers on M-250 employ extremely lightweight, copper-clad aluminium wire voice-coils, whereas the M-375 and M-675 use a voice-coil made of pure copper, to provide a better low-frequency response and higher power handling. All three models also incorporate DALI's patented SMC technology to minimise hysteresis and distortion in their magnet systems.

The diaphragm is perforated between the spider and the dust cap in order to improve the airflow and motor system cooling. This ensures better power handling and reduces thermal compression.

The wood fibre diaphragm is a blend of a fine grain paper pulp, reinforced with wood fibres, which result in a rigid, light-weight and well-behaving structure.

In combination with a low-loss surround and spider suspension, this diaphragm reproduces the micro dynamics of the signal - unfiltered and with high accuracy.

**M-250 BASS/
MIDRANGE**

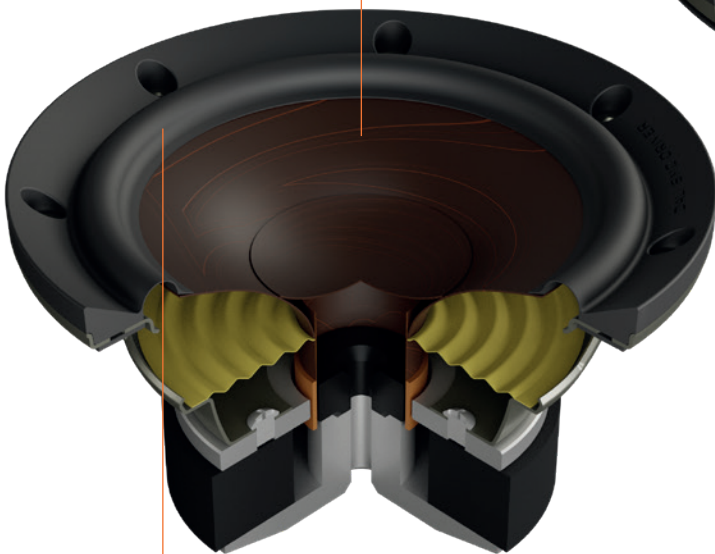

The diaphragm is terminated by rubber surround, chosen for its flexibility and minimal hysteresis. The surround allows the diaphragm to move freely, with very little damping effect, and enables the motor system better control of diaphragm movement.

**M-375 &
M-675 BASS/
MIDRANGE**

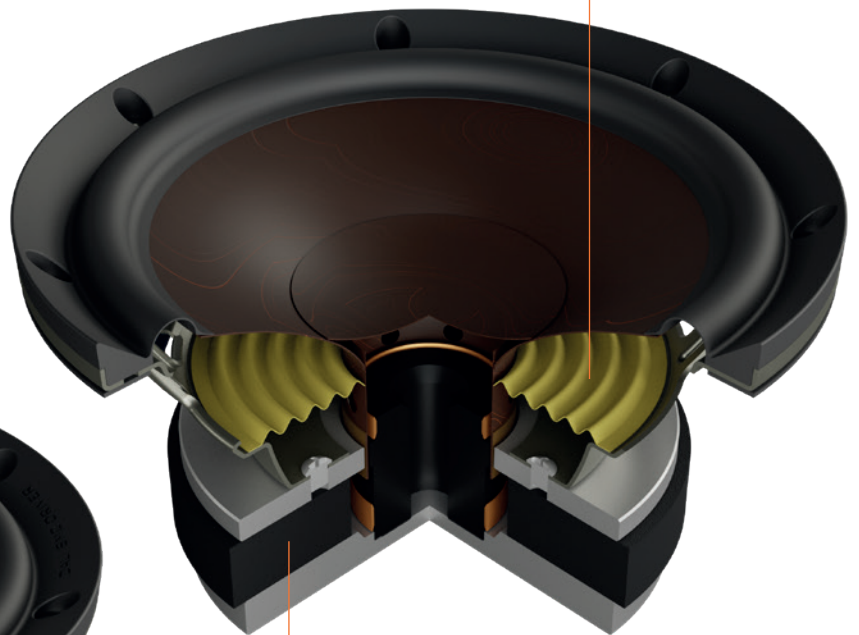

The magnet of the M-375 has a diameter of 120mm, ensuring maximum control of the driver.

Passive radiators

The dual and quad 180mm passive radiators of the M-375 and M-675 respectively are optimised for the two enclosure volumes. The rear surface of the passive radiator diaphragms are loaded with small steel weights used to tune the combined driver and enclosure systems for optimal low frequency performance.



The twin reflex ports of the M-250 reinforce the low frequency performance to increase both bandwidth and maximum volume. Both ports have been fully optimized for lowest possible port noise by using our custom Dual Flare bass reflex technology.



There are two passive 7" radiators on the M-375

Whilst the PHANTOM M-250 employs two reflex ports, the PHANTOM M-375 and M-675 employ passive radiators. Passive radiators work in a similar manner to reflex ports; using the low frequency energy radiated from the rear of the bass/midrange drivers to extend bandwidth, but they can be tuned more effectively, especially in slim enclosures, and enable higher volume levels to be achieved without compression or port noise.

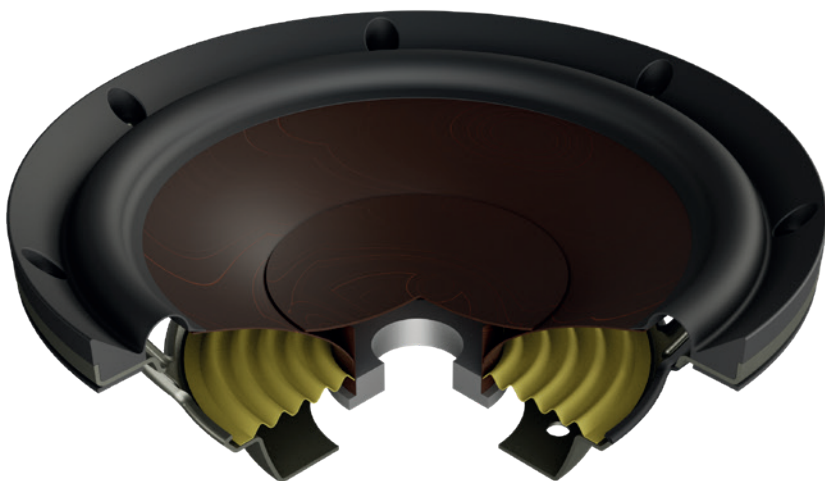

The M-375 and M-675 passive radiators feature an oversize suspension made from a Nomex® material that does not degrade over time as can conventional suspension materials when subjected to the high displacement demands of a passive radiator. The Nomex® spider is also more robust and durable at high sound pressure levels.

Tweeter

Dome tweeter

The in-house manufactured, ultra-lightweight 28mm soft dome tweeter of the PHANTOM M-Series takes care of the high frequency band. Built for maximum dynamics, high power handling and fantastic integration with midrange frequencies, the tweeter is more than a match for any musical challenge.

The 28 mm diameter dome is based on an ultra-lightweight woven fabric. At 0.06 mg per mm², the dome material is less than half the density of comparable soft dome tweeter materials. The relatively large-sized dome enables the tweeter to generate high sound pressure levels with less excursion, keeping voice-coil displacement to a minimum. And the tweeter is particularly optimised for extended response in its lower frequency band. This helps ensure optimal integration with the bass/midrange drivers and ensures balanced, informative and coherent midrange performance.

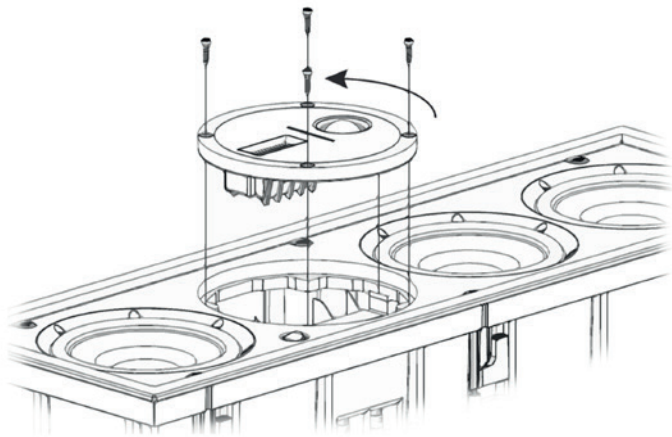

Ribbon tweeter

The unique combination of the soft dome and ribbon tweeter forms the DALI hybrid tweeter used in the PHANTOM M-375 and M-675. The ribbon tweeter is gradually rolled-in above 10 kHz, and reaches a full contribution from 14 kHz to well beyond 30 kHz. The ribbon tweeter adds ambience and detail to the system's high frequency performance. The ribbon tweeter is also exceptional in wide horizontal dispersion of high frequencies, and a superb partner for the soft dome tweeter's abilities at lower frequencies.

DALI PHANTOM M-250:
28 mm ultra-light soft
dome tweeter

Equipped with a damped rear chamber and structural bracing, the ribbon tweeter is isolated from the influence of the bass/midrange drivers and passive radiators.



DALI PHANTOM M-375 & M-675:
The rotatable hybrid tweeter consists of a combined 28 mm ultra-light soft dome unit and a ribbon tweeter.

When using the M-375 or M-675 in a landscape orientation centre channel role, the hybrid tweeter module can be rotated in order to maintain wide and symmetrical horizontal dispersion. To rotate the hybrid tweeter module it is simply unscrewed and turned 90° so that the ribbon tweeter is positioned uppermost.



The the ribbon tweeter chassis is made from glass reinforced ABS covered by a thin aluminium trim.

Crossover

Crossovers networks use high and low-pass filters to combine the bass/midrange and tweeter driver outputs and create linear, wide-bandwidth acoustic performance. Crossover configurations are designed and optimised for each type of speaker model.

The crossovers of the M-250, M-375 and M-675 are similar in concept but differentiated in detail to match their respective driver configurations.

DALI PHANTOM M-250 CROSSOVER

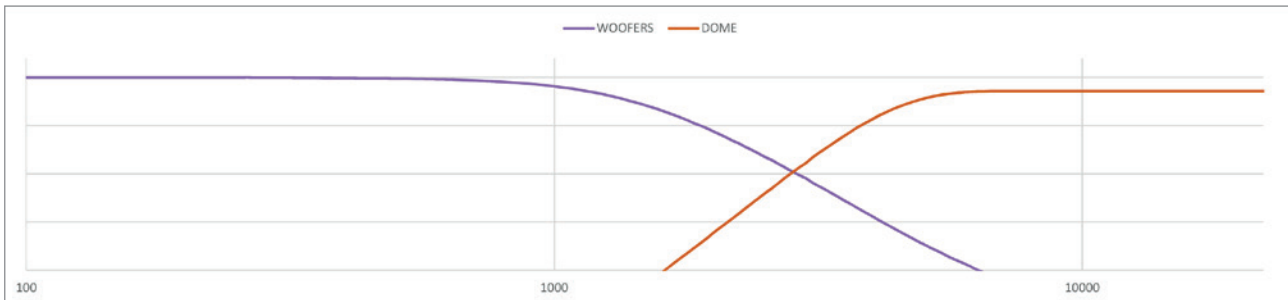

On the M-250, the crossover frequency between the bass/midrange driver and dome tweeter occurs at around 2.7kHz. This is where the bass/midrange driver rolls-off and the tweeter rolls-in.

DALI PHANTOM M-375 & M-675 CROSSOVER

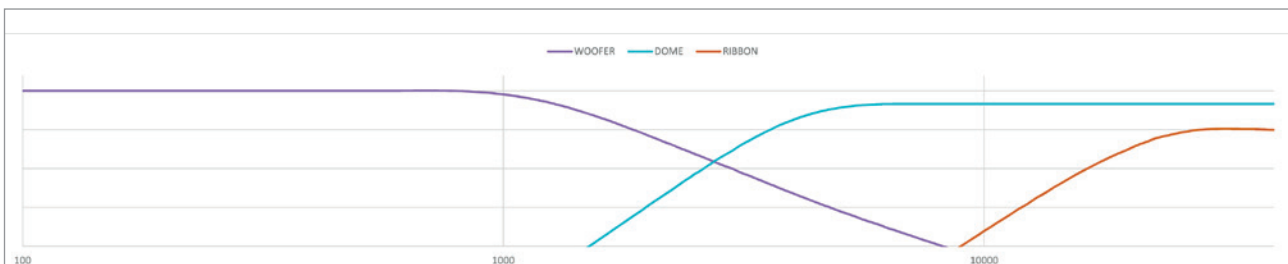

On the M-375 and M-675, the crossover frequency between the bass/midrange driver and dome tweeter occurs at around 2.7kHz. This is where the bass/midrange driver rolls-off and the tweeter rolls-in. At 15kHz the ribbon tweeter is rolled-in to support the dome tweeter.

Overload protection EQ options

The PHANTOM M-Series feature PTC (Positive Temperature Coefficient) overload protection systems on both bass/midrange drivers and tweeters. The PTC systems will attenuate the input signal if the volume is too loud for an extended period in order to prevent loudspeaker damage. Once the input signal is removed, the PTC system will automatically reset, however following a PTC protection event, the system may display slightly increased sensitive for a few days.

The HF+ switch adjusts the crossover to boost high frequencies slightly. This can be useful if, for example, M-Series speakers are located behind a video/projector screen that is not fully acoustically transparent.



Voice-coil in detail

DALI PHANTOM M-250

The PHANTOM M-250 bass/midrange driver features a 4-layer 25 mm coil. While a 4-layer voice-coil is effective for a high force factor, the higher moving mass will often present a challenge for the midrange response, impairing intelligibility in voice reproduction. Our solution is to minimise moving mass by using a copper clad aluminium voice-coil wire.

Combining the high conductivity/weight ratio of aluminium (205% the value of copper), with the superior resistance properties and better mechanical strength of copper -we get a lightweight voice-coil with high conductivity, capable of handling high peak signal levels.

The result is seriously improved bass control, well controlled reproduction of micro details and exceptional transient capabilities.

Cross section of a four layer voice-coil.

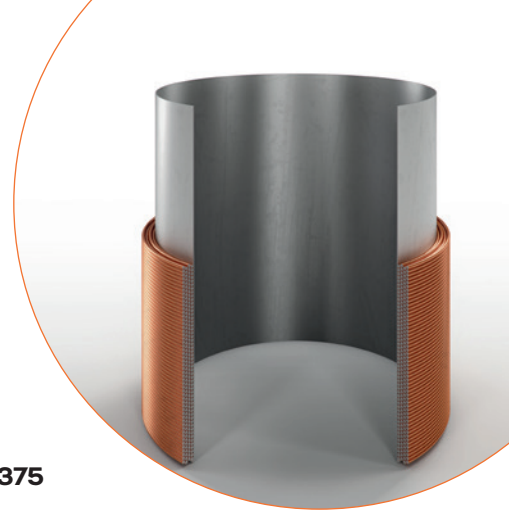

DALI PHANTOM M-375 and M-675

The PHANTOM M-375 and M-675 bass/midrange drivers incorporate a diaphragm similar to the acclaimed 8 inch DALI PHANTOM S driver, but downscaled to 7 inch. The diaphragm profile is optimised to reduce any breakup modes.

The PHANTOM M-375 voice-coil is not just inspired by the DALI PHANTOM S – it is identical. It comprises a two-layer pure copper voice-coil with a diameter of 38 mm to ensure fantastic power handling and minimal thermal compression.

On the M-675 the bass/midrange drivers are upgraded with new rubber surrounds and new four-layer pure copper voice-coils to provide a better low frequency response and a higher power handling.

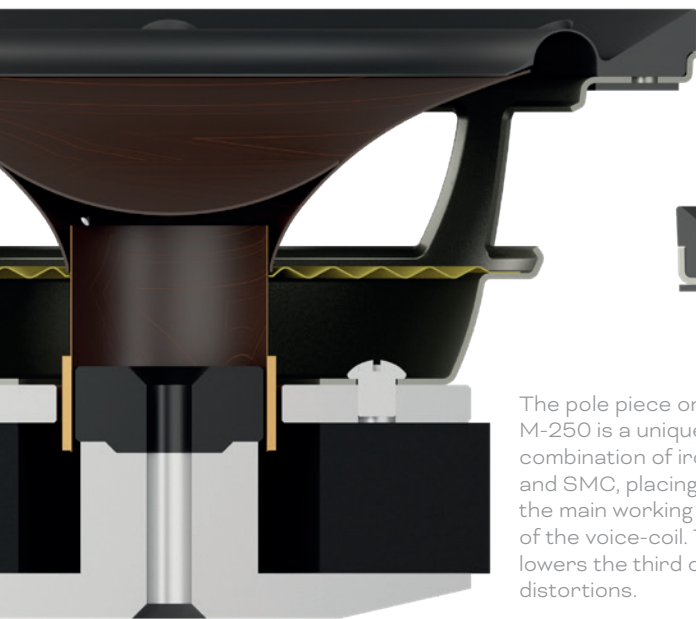

The pole piece on M-250 is a unique combination of iron and SMC, placing it in the main working area of the voice-coil. This lowers the third order distortions.

The polepiece

The pole piece of the M-375 and M-675 magnet system applies the same amount of SMC as found in the DALI PHANTOM S series.

The two metallic rings on the pole piece are used as shielding to concentrate the magnetic flux. On the M-375 the rings are made from aluminium, and on M-675 they are made from copper.

This technology is used for lowering distortion to an absolute minimum.

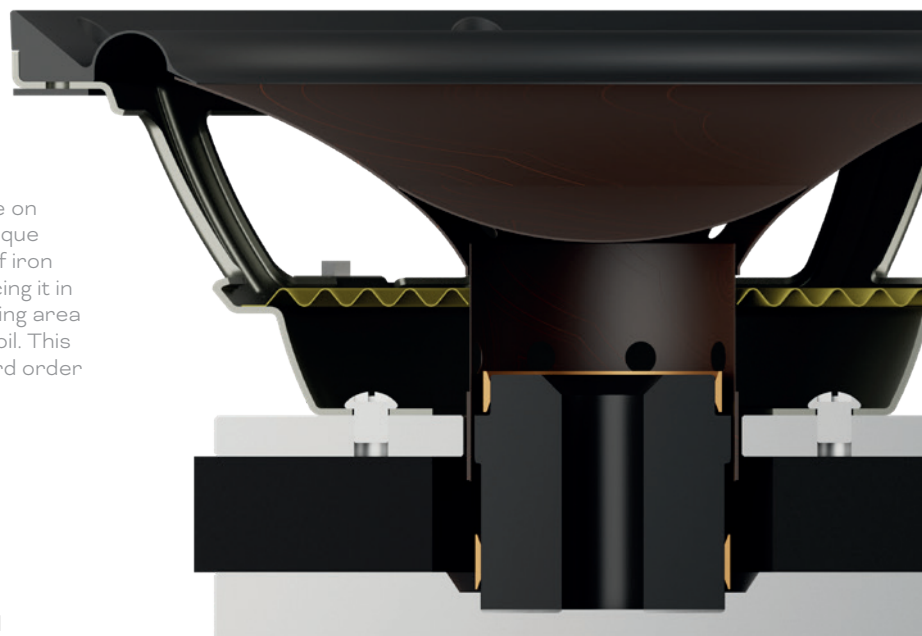

The pole piece on M-375 has a core of pure SMC, minimizing distortion even further.

SMC in details

Low Loss Magnetism

The use of SMC (Soft Magnetic Compound) has many advantages, but the overriding result is a significant reduction of distortion from losses in the motor system (magnet assembly and voice-coil).

SMC's unique ability to deliver a high magnetic conductivity and very low electrical conductivity results in all the desired qualities of an exceptional speaker magnet, without the traditional disadvantages.

When using iron-based components in speakers, the magnetisation and demagnetisation introduced by the shifting current directions, do not happen at the same pace. The demagnetisation process is slower than magnetisation. This phenomenon is called hysteresis, and is a known problem in almost all speaker motor systems.

The problem with hysteresis is that it introduces an unintended resistance to the voice-coil, resulting in distortion. The reason hysteresis occurs is because iron is not only magnetically conductive, but also electrically conductive.



Exploded view of the voice-coil used in the DALI PHANTOM M bass/midrange driver

SMC, on the other hand, is highly magnetically conductive, but has a very low electrical conductivity (approx. 1/10,000's of iron). The result of using SMC is minimal hysteresis and distortion.

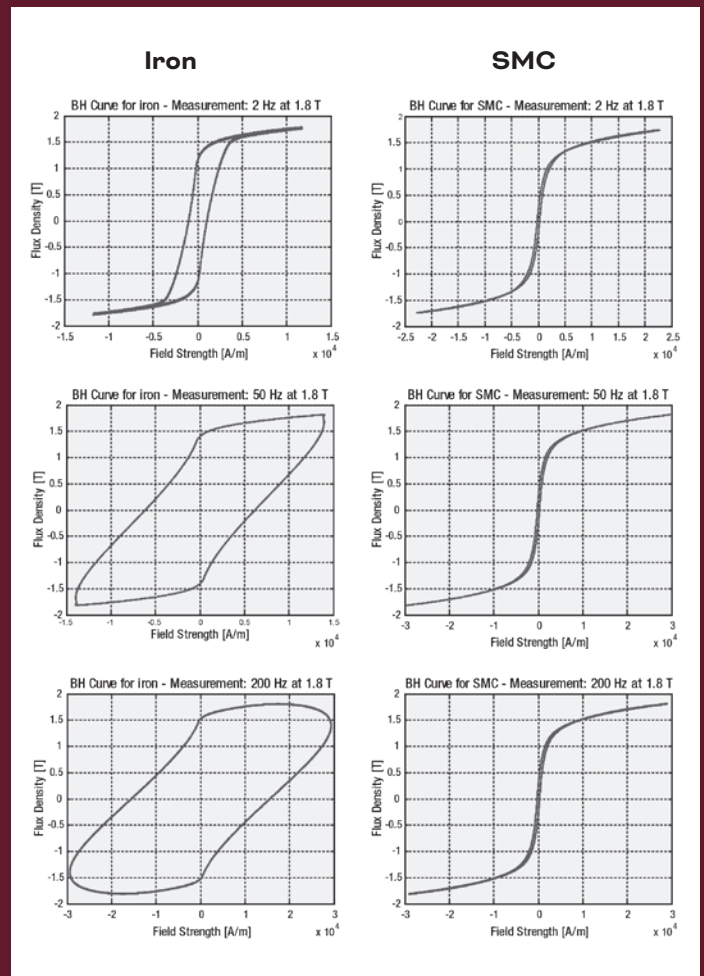

The above graphs show the hysteresis of iron based magnets in comparison to SMC. There is almost no hysteresis, and therefore no distortion, when using SMC.

Current linearity

In a traditional iron magnet system, the current in the voice-coil will modulate the flux in the magnet gap. This flux modulation is a cause of distortion and creates a working environment for the voice-coil, this is far from ideal. The modulation of the magnetic flux is caused by the iron being electrically conductive.

By introducing SMC into the area close to the magnet gap, the modulation is significantly less influenced by the current in the voice-coil. As a result, distortion from current-generated flux variations is much reduced.

Inductance Linearization

Making DALI speakers amplifier-friendly is an important part of the design process. To get the best from the amplifier, the speaker has to deliver a stable impedance. By keeping the impedance as linear as possible across the entire audio range, the amplifier is able to deliver the same amount of power at all frequencies. However, in many traditional speaker motor systems the voice-coil inductance depends on the position of the voice-coil, which means the impedance varies with both frequency and level.

The fine grain
of SMC

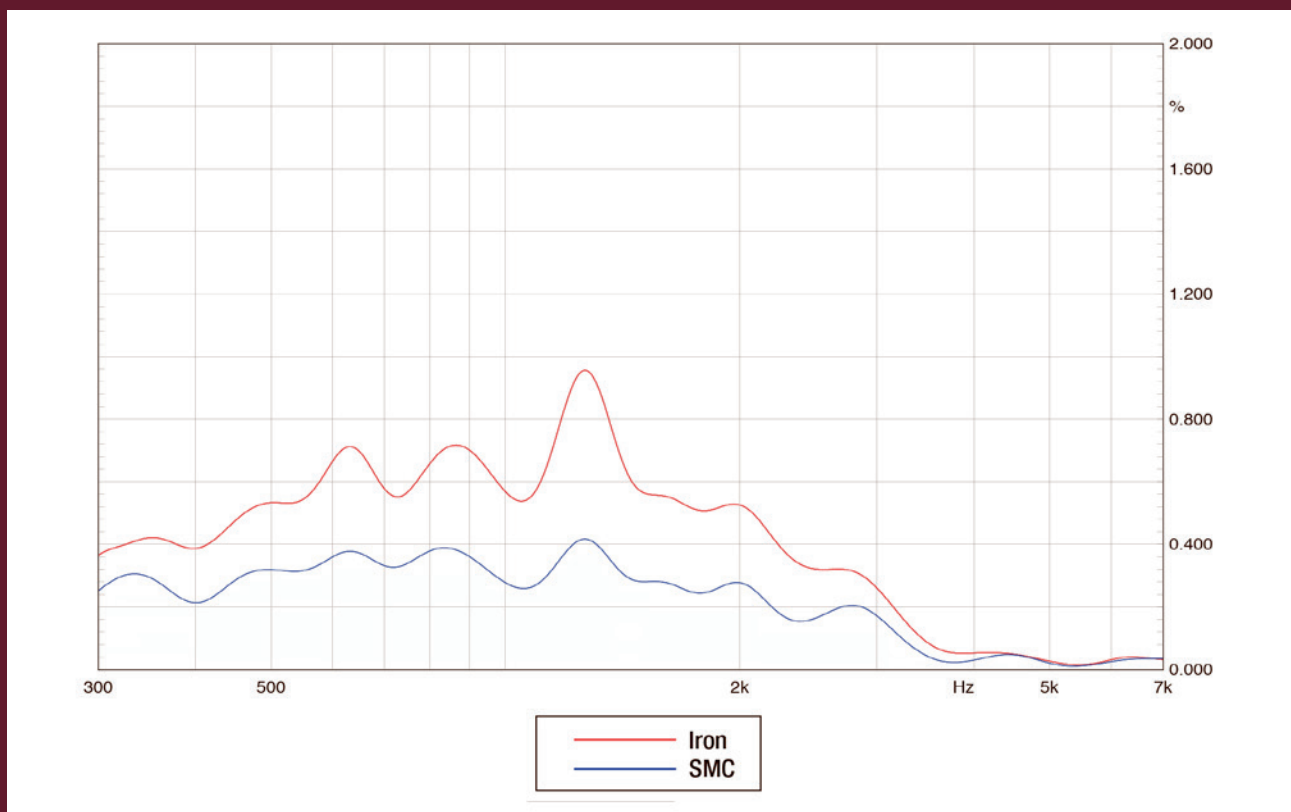
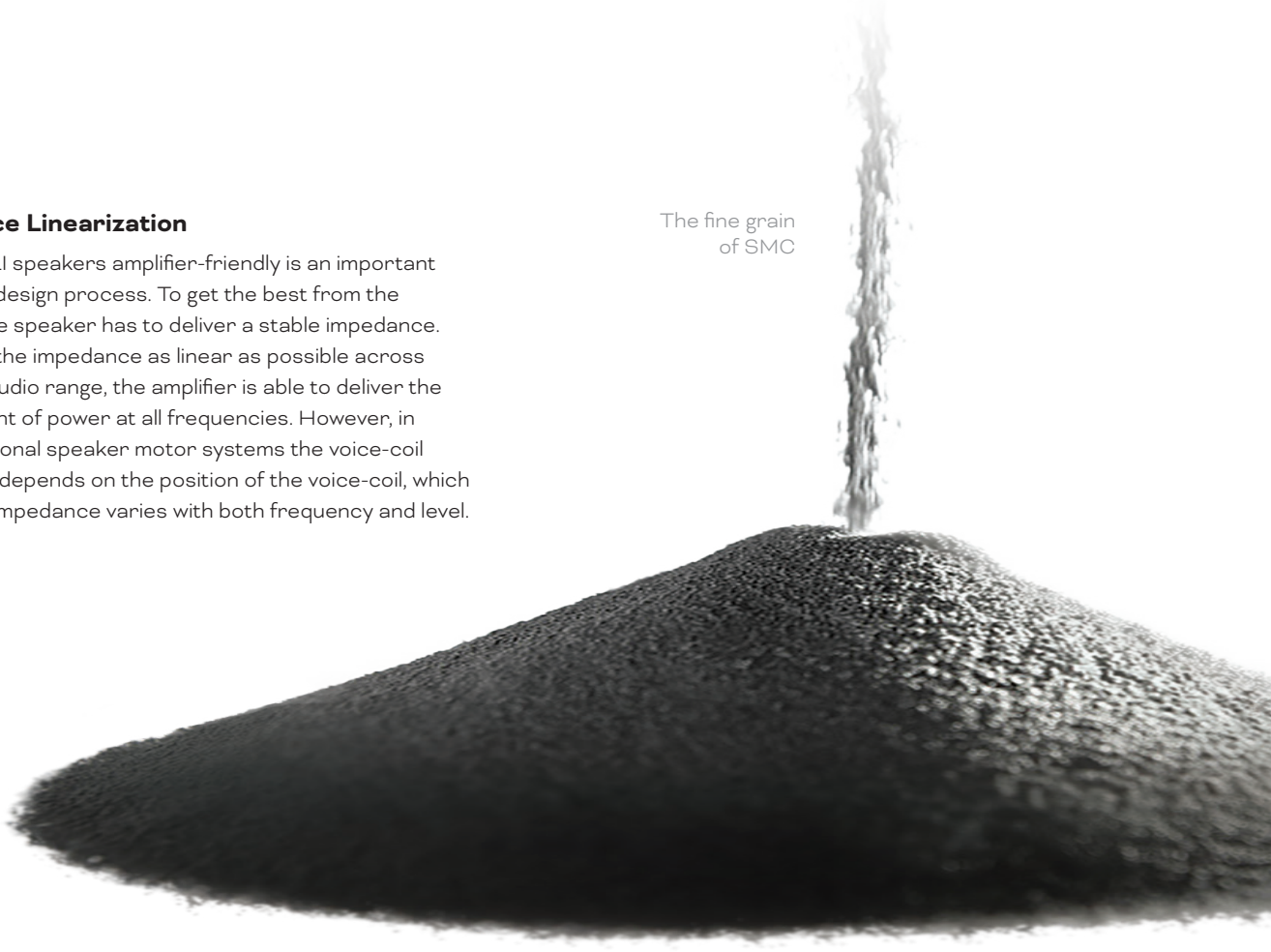

Generic example of 3rd-order distortion of iron, compared to SMC.

Speaker positioning

For active listening, speaker positioning can be just as significant as their inherent sound quality. The listener may need to spend time considering the positioning of their speakers in order to achieve the optimal setup. With both stereo and surround systems, the distance between the listener and the sound source needs to be considered in order to optimise the speakers performance.

The enclosure is 10 cm in depth and measures 0,6 cm from the wall after being installed.



The installed frame will fit with a minor distance from the wall and with a very discreet expression when attaching the grill.

If wall apertures are impractical or undesired, on-wall frame accessories are available for all DALI M-Series speakers. Frames can be mounted directly onto the wall and then the speakers installed within.

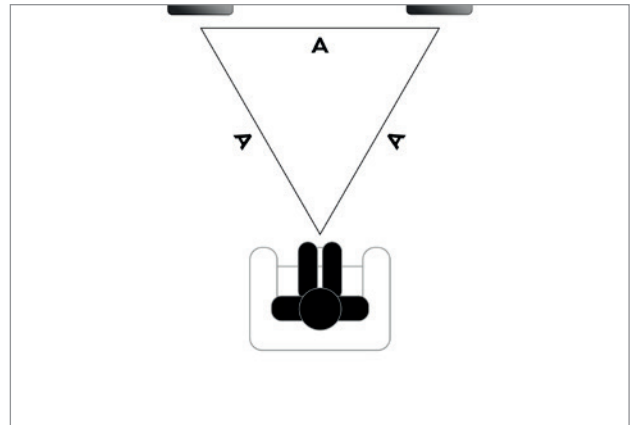

STEREO SETUP: The optimal setup is created by arranging an equilateral triangle between the loudspeakers and listening position, as shown in dimensions A.

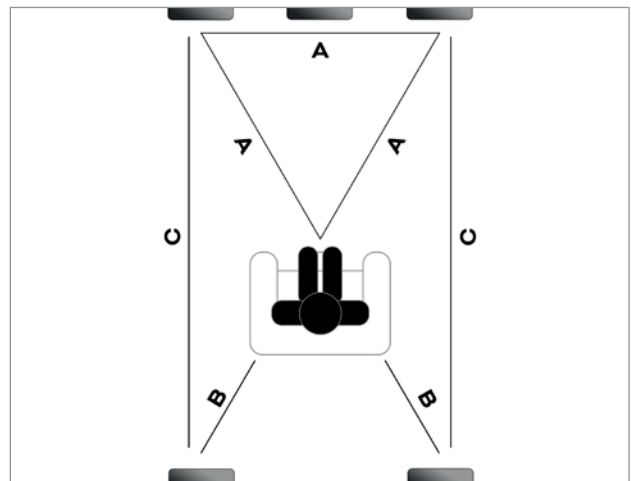

SURROUND SETUP: The optimal setup is created by creating an equilateral triangle, as shown in dimensions A. The rear speakers should be parallel with the front speakers, shown in dimension B. Dimension C can be less than dimension A.

The On-wall frame accessory for DALI PHANTOM M-Series speakers.



Technical specifications

| DALI PHANTOM | M-250 | M-375 | M-675 |
|---|--|---|---|
| Frequency range | 58 - 24,000 Hz ±3 dB | 57 - 25,000 Hz ±3 dB | 49 - 25,000 Hz ±3 dB |
| Sensitivity | 89 dB @ 1 m for 2.83 V | 89 dB @ 1 m for 2.83 V | 90 dB @ 1 m for 2.83 V |
| Nominal impedance | 6 ohm | 6 ohm | 4 ohm |
| Maximum SPL | 107 dB | 107 dB | 110 dB |
| Crossover frequency | 2,700 Hz | 2,500 / 15,000 Hz | 1,000 / 2,800 / 15,000 Hz |
| Recommended amplifier power | 30 - 180 Watt | 30 - 180 Watt | 40 - 300 Watt |
| High frequency driver | 1 x 28 mm soft dome | 1 x 28 mm soft dome 1 x 17 x 45 mm ribbon | 1 x 28 mm soft dome 1 x 17 x 45 mm ribbon |
| High frequency diaphragm | Soft woven fabric | Soft woven fabric | Soft woven fabric |
| Low frequency driver/ Mid-range driver | 2 x 5 inch | 1 x 7 inch | 2 x 7 inch |
| Low/Mid frequency diaphragm | Wood fibre cone | Wood fibre cone | Wood fibre cone |
| Connection input | Single wire | Single wire | Single wire |
| Enclosure type | Bass reflex enclosure, 2 x ports | Tuned mass enclosure, 2 x 7 inch passive radiators | Tuned mass enclosure, 4 x 7 inch passive radiators |
| Functions | Normal / HF+ | Normal / HF+ | Normal / HF+ |
| Installation location | In-wall / On-wall | In-wall / On-wall | In-wall / On-wall |
| Recommended placement | Front / Centre / Rear / Surround | Front / Centre / Rear / Surround | Front / Centre / Rear / Surround |
| Dimensions (H x W x D) | 775 x 250 x 106 mm 30.5 x 9.8 x 4.17 inches | 775 x 250 x 106 mm 30.5 x 9.8 x 4.17 inches | 1322 x 250 x 106 mm 52 x 9.8 x 4.17 inches |
| Cut-out dimensions (H x W x D) | 751 x 226 x 105 mm 29.6 x 8.9 x 4.13 inches | 751 x 226 x 105 mm 29.6 x 8.9 x 4.13 inches | 1298 x 226 x 105 mm 51.1 x 8.9 x 4.13 inches |
| Installation depth | 100 mm 3.94 inches | 100 mm 3.94 inches | 100 mm 3.94 inches |
| Panel thickness | 8 - 48 mm 0.3 - 1.9 inches | 8 - 48 mm 0.3 - 1.9 inches | 8 - 48 mm 0.3 - 1.9 inches |
| Panel thickness (Reversed doglegs) | 48 - 68 mm 1.9 - 2.7 inches | 48 - 68 mm 1.9 - 2.7 inches | 48 - 68 mm 1.9 - 2.7 inches |
| Weight | 9 kg 19.8 lb | 9.18 kg 20.2 lb | 16 kg 35.2 lb |
| Shipping weight | 10 kg 22 lb | 10.2 kg 22.5 lb | 17.7 kg 39 lb |
| Finish | White | White | White |
| Accessories | Manual Cut-out template Front grille | Manual Cut-out template Front grille | Manual Cut-out template Front grille |
| Optional accessories | On-wall frame | On-wall frame | On-wall frame |

All technical specifications are subject to change without notice.