

## Highlights:

- Punched square holes for use with snap-in cage nuts
- 400 mm usable depth
- Detachable front & rear cover
- High quality 15 mm plywood
- Hardware by Penn Elcom
- Protective rubber feet
- Truly modular & flexible solution for 19" equipment
- Ergonomic carry handles
- Durable & scratch resistant textured EPDM paintwork
- Perforated rack rail on both sides
- Open sides for optimal ventilation
- Cable feedthrough on rear side
- Protruding Teflon tongue profile for transport fixation
- Compatible with FCE series trunk cases



The FCI102 is a modular rack system for professional equipment handling, allowing storage for 19" equipment up to two rack spaces which compliant to the ANSI/EIA RS-310D, DIN41491 and IEC60297 standards for 19" equipment installation.

It offers a flexible solution for carrying your gear in a convenient and secure way to your job. Multiple FCI units can be combined together in matching trunk cases for transportation, while storage and usage is possible when removed from the transportation cases. The construction is made of high-quality 15 mm plywood materials finished in a durable and scratch resistant EPDM paintwork. Its front and rear covers are removable through firm slam locks. Mounting of the equipment can be done on both front and rear side using the perforated rack rail with punched holes and cage nuts. Ergonomic carry handles offer easy carriage of the system while a rear side cable inlet allows everything to be connected while the rear cover is attached. Optimal ventilation is guaranteed through open sides.

The inside usable depth measures 400 mm from profile to profile, with a maximum depth of 430 mm. Superior durability is guaranteed through Penn-Elcom® slam latches.

## Product Features:

Dimensions	542 x 130 (133) x 545 mm (W x H (incl. feet) x D)
Max. usable depth	(profile to profile) 400mm ~ (max depth) 430 mm
Construction	15 mm high-quality plywood
Finish	Durable & scratch resistant textured EPDM paintwork
Handles	2 x Integrated ergonomic carry handles (front)
Latches	4 x Mini slam latch (L2455)

## Variants:

---

- FCI102/B - Black version

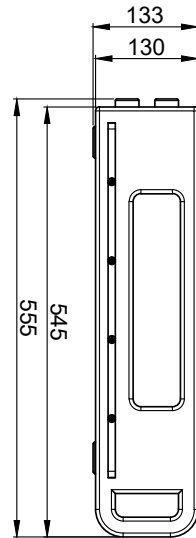
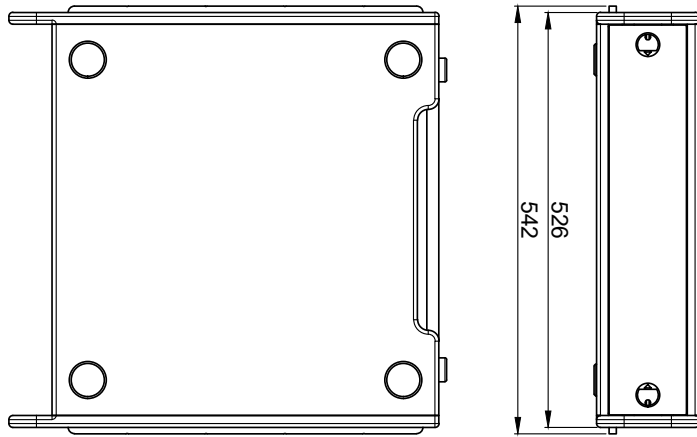

		<b>FCI102</b>	<b>Product description:</b> 19" RACK INSERT FOR FLIGHTCASE - 2 HE - 545 MM DEPTH	<b>Outer dimensions:</b> (w x h x d) 542 x 133 x 555	<b>Unit height:</b> 2 HE