

Specifications

SMART wall mount kits for SMART Board® interactive displays

Models WM-SBID-501 and WM-SBID-502

Overview

SMART offers two wall mount kits for installing SMART Board® interactive displays. Both wall mounting kits use a VESA-standard mounting hole pattern and are also compatible with SMART's wall stand kit.

Dimensions and weights¹

WM-SBID-501

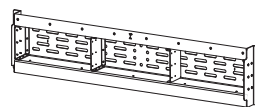
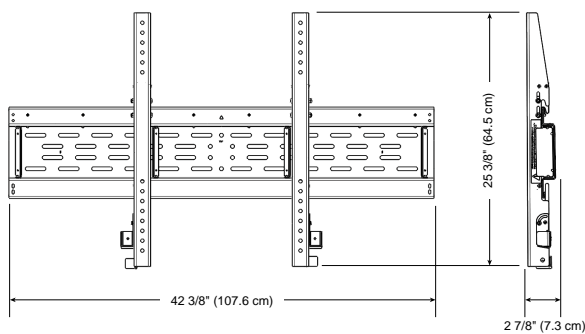

Maximum supported interactive display weight

276 lb. (125 kg)

Shipping dimensions

46" W × 12 1/2" H × 11" D
 (117 cm × 32 cm × 28.1 cm)

Shipping weight

31 lb. (14 kg)

WM-SBID-502

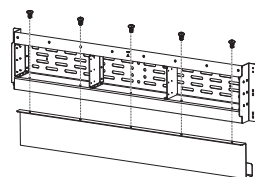
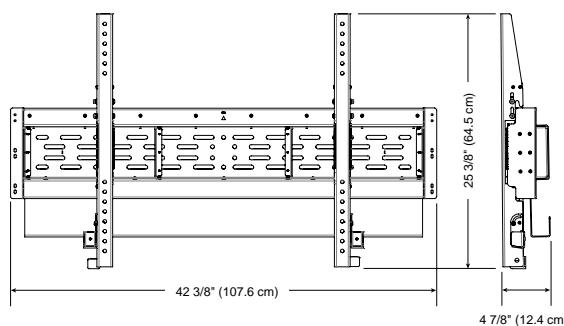

Maximum supported interactive display weight

276 lb. (125 kg)

Shipping dimensions

46" W × 17 1/2" H × 13 3/8" D
 (117 cm × 44.3 cm × 33.9 cm)

Shipping weight

46 lb. (21 kg)

¹All dimensions ± 1/8" (0.3 cm). All weights ± 2 lb. (0.9 kg).

Standard features

VESA mounting compatibility The WM-SBID-501 and WM-SBID-502 wall mount kits are compatible with the following range of VESA mounting hole patterns: 400mm × 300mm to 900mm × 500mm.

Included hardware Includes hardware for mounting the brackets to a SMART display and to the wall. (The hardware for connecting the display to the mount may not be compatible with non-SMART displays.) The wall mounting hardware is included for mounting on solid concrete or wood-framed walls.

Storage and operation requirements

Operating temperature 41–95°F (5–35°C)

Storage temperature -40–140°F (-40–60°C)

Humidity Humidity 85% relative humidity, non-condensing

Certification and compliance

Regulatory certification cULus

Environmental compliance

European Union REACH, RoHS and Packaging

U.S. CONEG Packaging, California Proposition 65 and Conflict Minerals

Purchasing information

Order numbers

WM-SBID-501 SMART wall mount kit for SMART Board interactive flat panels

WM-SBID-502 SMART wall mount kit for SMART Board interactive flat panels

Related products sold separately

WSK-SINGLE Single wall stand kit, including one wall stand and one cable raceway

WSK-DUAL Dual wall stand kit, including two wall stands and one cable raceway

See smarttech.com/kb/170526 for more information on these products.

Warranty One-year limited equipment warranty

smarttech.com/support
smarttech.com/contactsupport

© 2018 SMART Technologies ULC. All rights reserved. SMART Board, smarttech, the SMART logo and all SMART taglines are trademarks or registered trademarks of SMART Technologies ULC in the U.S. and/or other countries. All third-party product and company names may be trademarks of their respective owners. This product and/or use thereof is covered by one or more of the following U.S. patents: www.smarttech.com/patents. Contents are subject to change without notice. 10/2018.