

## EC declaration of conformity

Manufacturer: celexon Germany GmbH & Co. KG  
Address: Gutenbergstraße 2, 48282 Emsdetten, DE

Hereby declares that the following product

Product name: celexon projector lift PL1000  
Part number: PL1000  
Manufacturer: celexon Germany GmbH & Co. KG,  
48282 Emsdetten, DE

Complies with the following standards:

**CE EN 50081-1, CE EN 50082-1**

### Notes:

The tests were carried out in normal mode and refer to the tested device under the specified tests. This certificate applies only to the devices tested.

Emsdetten, 10.07.2017

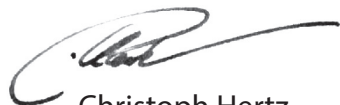

Christoph Hertz  
Managing Director



**celexon**<sup>TM</sup> 

[www.celexon.com](http://www.celexon.com)



# Installation Manual

celexon projector lift PL1000

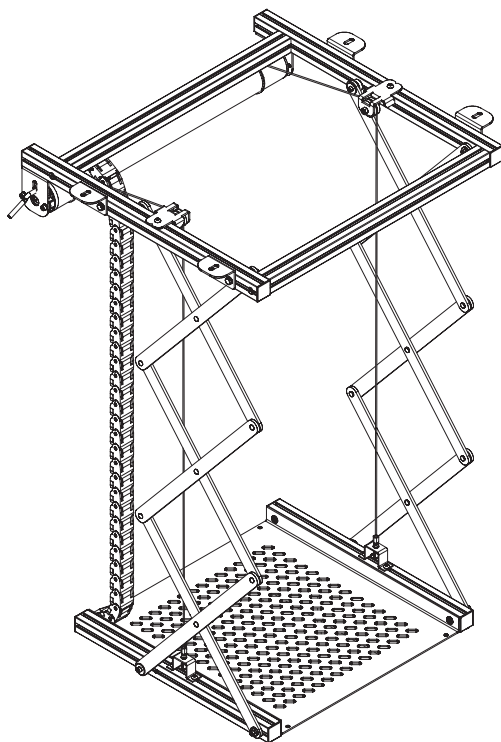

Thank you for purchasing this product. Before installing the projector lift, please read the following instructions carefully.

---

## Safety instructions

---

- Do not start installation before reading the complete installation manual and the safety warnings.
- This product should only be installed by qualified personnel (with mechanical and electrical experience).
- Please ensure that the ceiling can carry the complete weight of ceiling lift and mounted hardware.
- If necessary, carry out the installation with another person to ensure safe installation.
- Tighten the screws but ensure that they are not overtightened as this would reduce the load bearing capacity.
- This product is designed for indoor use only. Outdoor use could result in damage to the product and may cause injury.
- Hanging loads must be tested at least twice a year for strength and carrying capacity.
- Do not stand under the ceiling lift during operation.
- Do not dismantle the lift into its piece parts.
- Do not lean heavy loads against the projector or lift.

---

## Disclaimer

---

The information in this document is subject to change without prior notice. Changes will be documented in future editions of this manual. The manufacturer does not guarantee accuracy of the information contained in this document.

---

## Cleaning instructions

---

Clean the product only with a soft and clean cloth. If necessary, use a mild soapy solution to remove any dirt.

## Symbols



### Important:

This symbol is used to indicate recommendations, guidelines and information that are important when using the product.



### Danger:

This symbol is used to indicate safety instructions in this manual which must be strictly adhered to in order to ensure safe handling of this product. Failure to do so may result in serious injury or death.



### Warning:

This symbol is used to indicate safety warnings in this manual which could lead to injury or damage to the product if not observed.

## Product label

This ceiling lift is clearly identified by a product identification label that contains its key technical information.

- A Product type
- B Product name
- C Serial number
- D Year of manufacture
- E Operating voltage
- F Power frequency
- G Phases
- H Power consumption

<b>celexon Germany GmbH &amp; Co. KG</b> Gutenbergstraße 2 48282 Emsdetten Deutschland www.celexon.com					
A		C			
B		D			
E	F	G	H		

## Position of product label

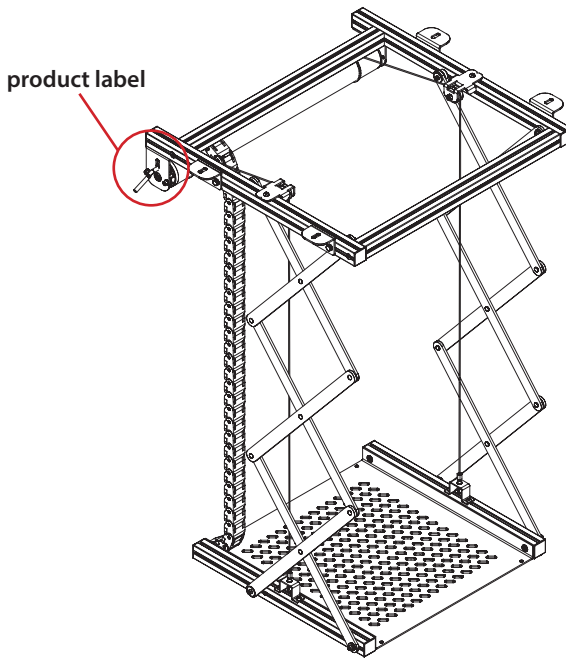

## Warnings

Warning 1 is important and must be followed:

It is possible to be harmed by the scissor joint if you are positioned too close. Please ensure that there is sufficient distance when using the lift and that people, cables or other objects are kept a safe distance from the mechanism.



Warning 1

## Warnings

Warning 2 refers to the maximum load capacity of the lift which is the total of the weight of the projector, the lift itself and the ceiling tile that is attached to the lift. The actual weight must never exceed the maximum load specified.

MAX LOAD   A   KG

MASSIMO CARICO   A   KG

Warning 2

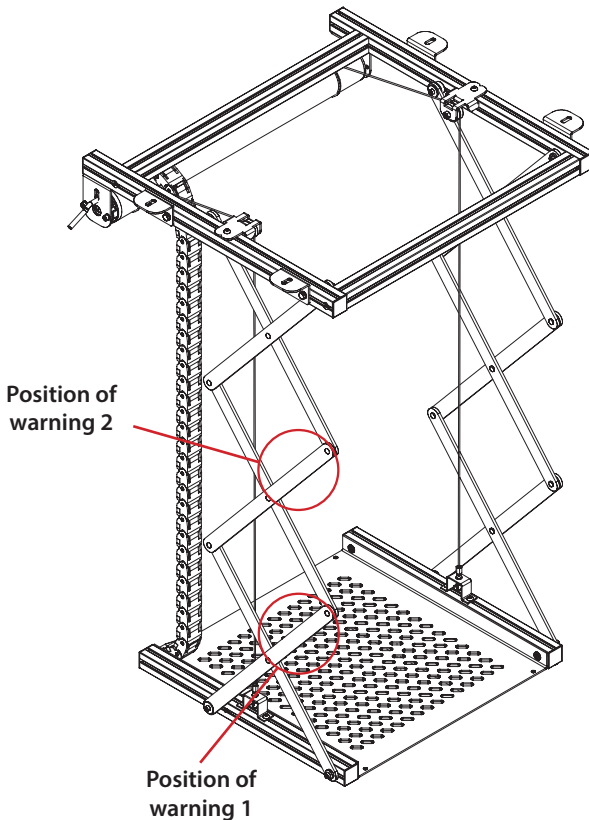

## Important advice for the installation and use

### **Important advice for the installation and use of the ceiling lift:**

The celexon ceiling lift PL1000 is a motorised lift for projectors. The lift should only be installed indoors, protected from environmental factors such as humidity, cold or heat.

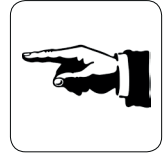

This product should only be installed by qualified personnel (with mechanical and electrical experience). After installation, only the owner or authorised personnel should use the ceiling lift. Please avoid misuse by third parties.

Before using the lift, you should be adequately instructed in its functions, as well as of any possible risks when using the lift. Operation should be strictly in accordance with the instructions in this manual.

It is strictly forbidden to use the lift contrary to these instructions or for a purpose that it was not intended for.

The above instructions must be observed by installers, technicians and all users.

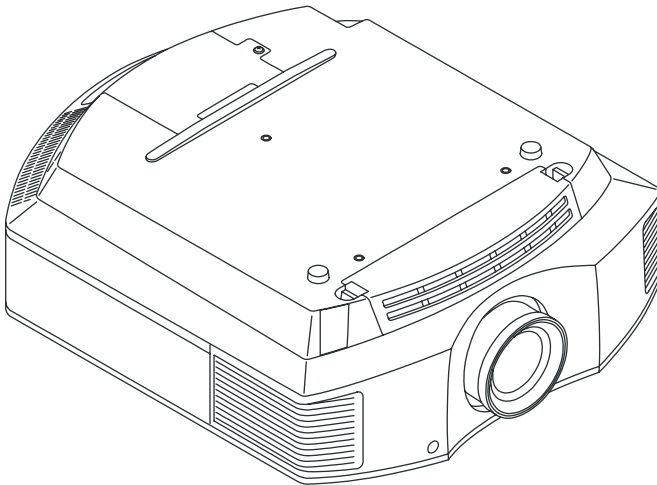

## Important advice for the installation and use

The lift is designed for professional use only. Failure to comply with these instructions may result in damage to the lift itself or to the video projector located therein and/or may create dangerous situations for which the manufacturer is not responsible or liable.

It is strictly **forbidden** to:

- Connect the lift to a different AC voltage than specified on the product label
- Use the lift to move animals or objects other than a projector
- Exceed the maximum load specified
- Install and use the lift outdoors



## Safety instructions and possible risks

- The lift should only be used for the purposes intended. The manufacturer does not accept liability for injury to people, animals or damage to objects due to improper or negligent use. **MAKE SURE THAT THE LIFT IS DISCONNECTED FROM THE MAINS BEFORE STARTING INSTALLATION, CLEANING OR MAINTENANCE WORK.**
- Do not remove any warnings or stickers attached to the lift.
- Do not activate the lift if it is not fully assembled and / or safety device is dismantled or safety warnings are missing.
- It is possible to stop the lift at any time by using the up / down switch if necessary.
- In the case of a defect or malfunction, please do not attempt any repairs on the lift, but contact your dealer or manufacturer.
- To connect the lift with the power cable you must follow the instructions in this manual (see section Electric connections).





## Description of safety devices

The lift is equipped with two safety screws which are located on the bottom left profile and the bottom right profile (see illustration below).

The screws can be positioned freely and will prevent the lift from dropping in the event of a defective rope.

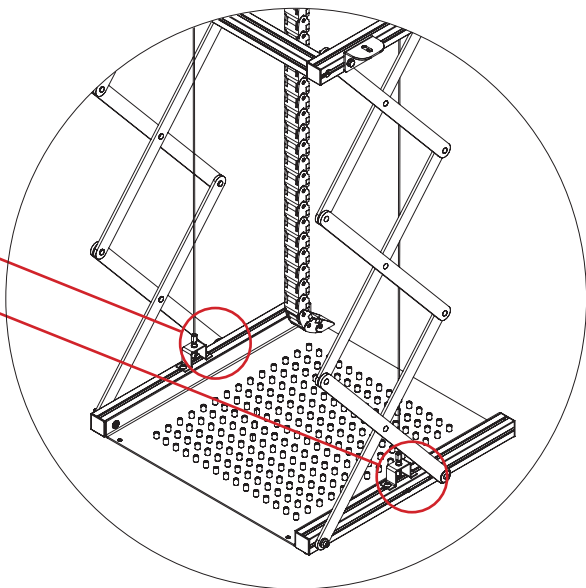
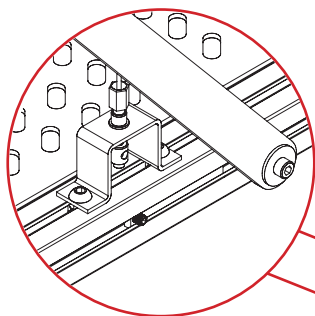

**Warning:** Once the lower stop position point has been set, fix both safety screws tightly with an allen key at a distance of 10mm from the scissor joint.

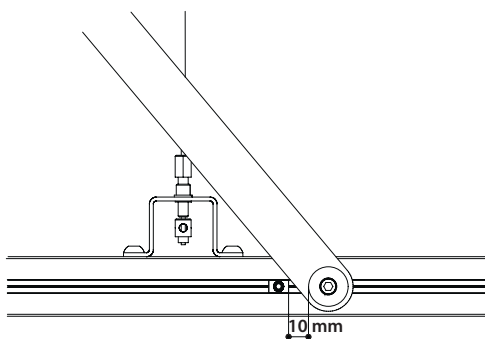

## Residual risks (rs)

Please ensure that no people, animals or objects are underneath the lift or near the area that the lift needs to move in and out when the lift is in use.

The drawing below identifies the residual risk area which should be avoided when using the lift and during installation of the projector.

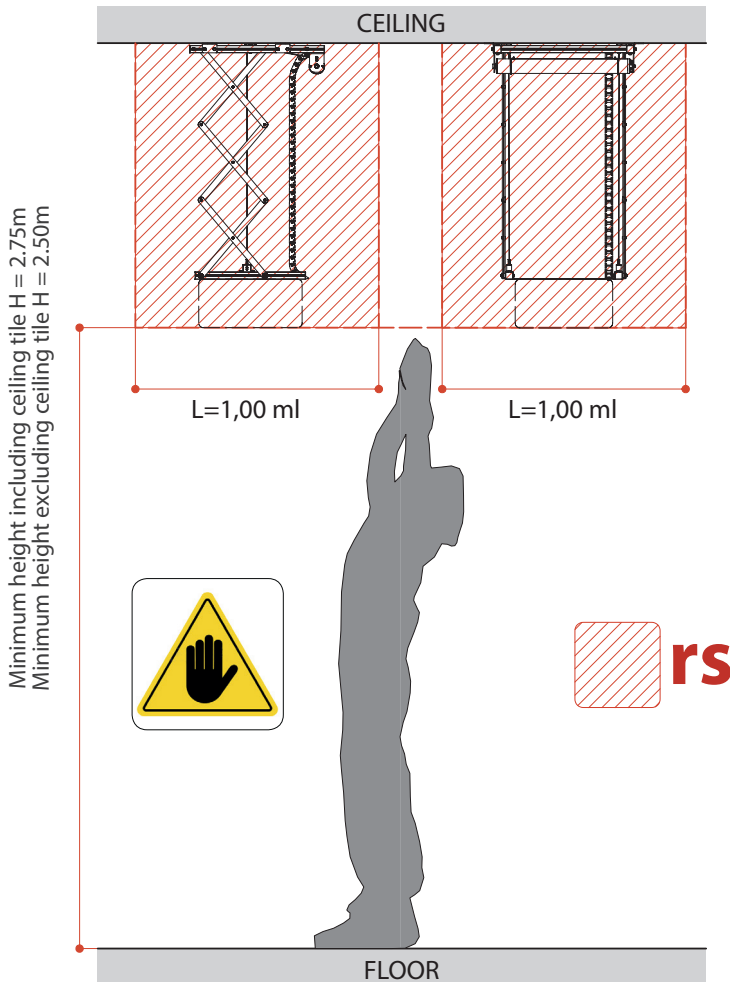

## General description of the projector lift

The following drawing provides an overview of the main components of the lift:

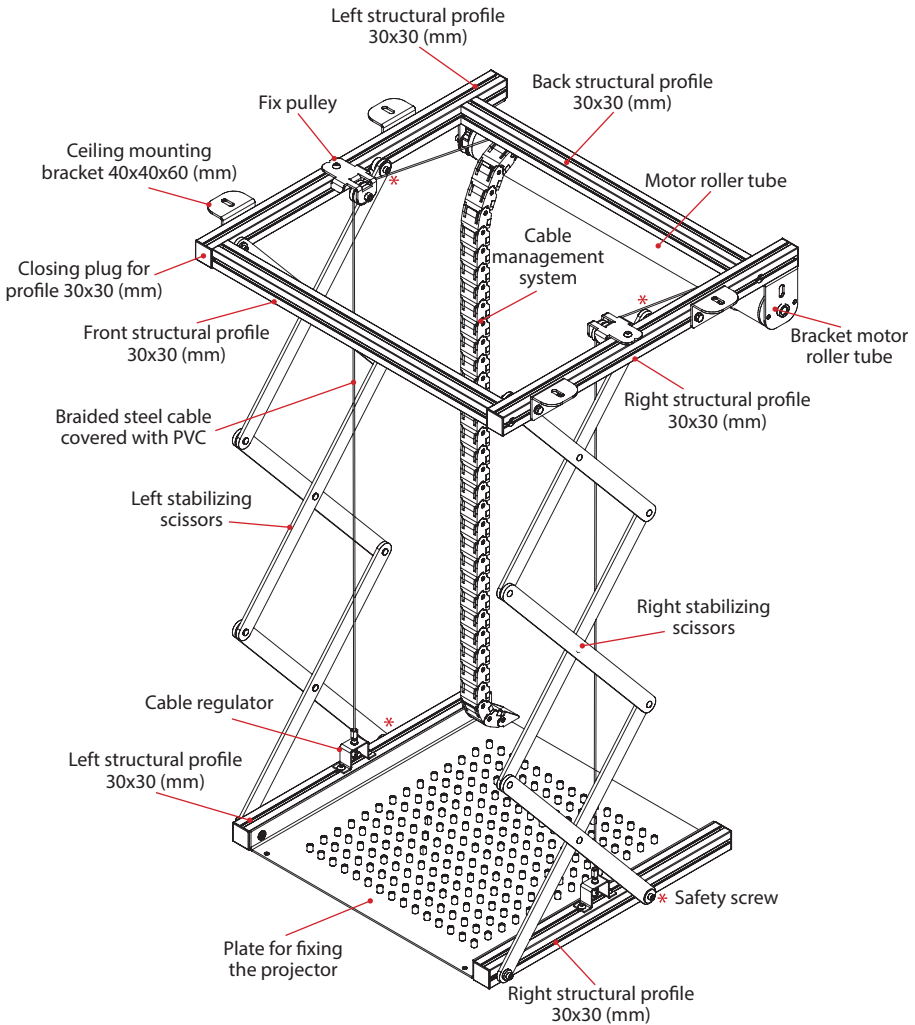

# Dimensions

Side view

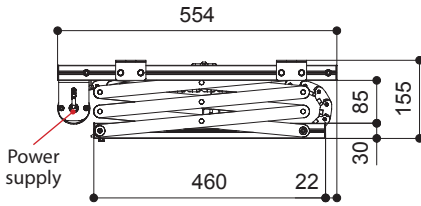

Rear view

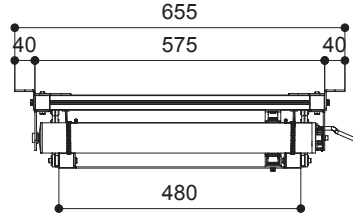
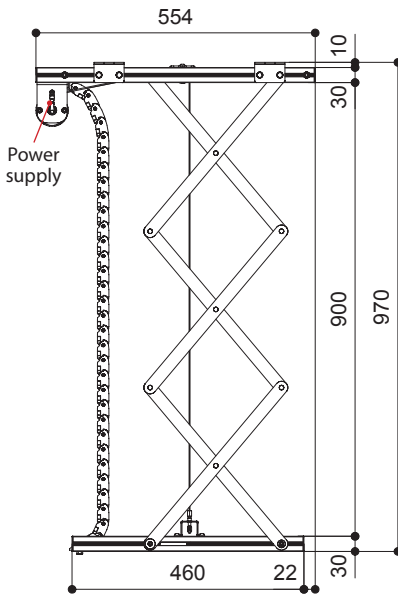

Fig: Lift retracted (mm)

Side view



Rear view

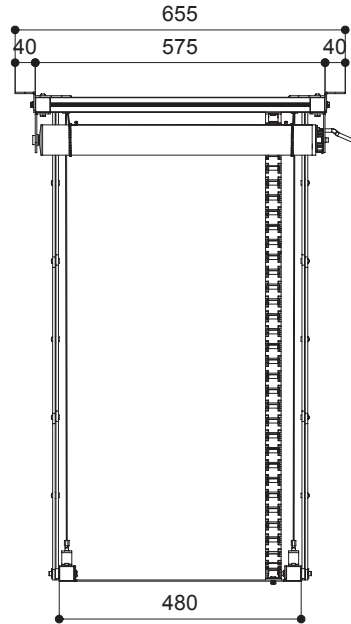

Fig: Lift extended (mm)

## Technische Spezifikationen

Dimensions 'lift retracted':	575 x 155 x 554 mm (WxHxD)
Dimensions 'lift extended':	575 x 970 x 554 mm (WxHxD)
Max usable area - projector hanging:	410 x 450 mm (WxD)
Max usable area - projector sitting:	350 x 450 mm (WxD)
Max size area of projector fixing points:	320 x 350 mm (WxD)
Max projector size:	560 x 550 mm (WxD)
Max load:	15 kg
Net weight of projector lift:	12 kg
Cable management system (inside):	20 x 18 mm (WxH)

## Motor specifications

GAPOSA motor, series XQ50P

Cod. XQ5P1017

Tubular motor with mechanical end stop points

Power supply:	230 V
Frequency:	50 HZ
Length of cable:	2.5 m
Cross-section lead :	4 x 0.75 mm <sup>2</sup>
Operating temperature:	-10°C / 40°C
Thermal protection:	4 Min.
IP protection class:	44
Torque:	10 Nm
Speed:	17 UpM
Max. power consumption:	156 W
Current consumption:	0.7 A

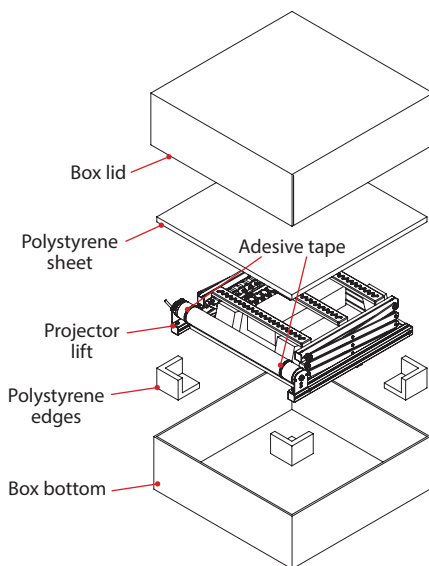

## Installation

Please check **PRIOR** to installation that you have received all the components listed below. In case one or more parts are missing, please contact your dealer from whom you purchased the product.

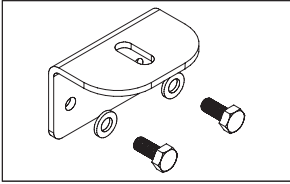

4 x L brackets for ceiling mounting  
with 8 screws and 8 washers

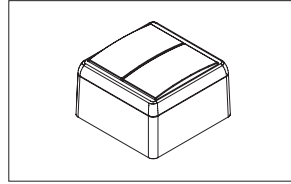

1 x wall mounted switch

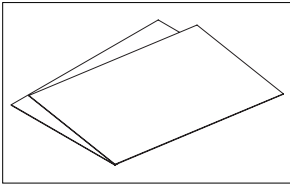

Installation and user guide

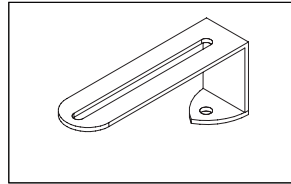

4 x sliding brackets to support false ceiling  
rods

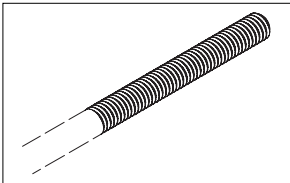

4 x M6x25mm threaded rod

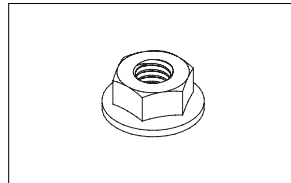

12 x M6 nuts

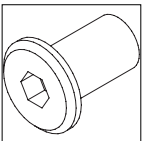

4 x M6 threaded sleeves

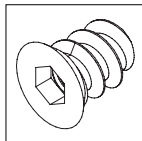

4 x M6 screws for  
connecting false ceiling  
tile

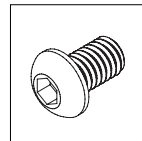

4 x M6x10 Hex head screws

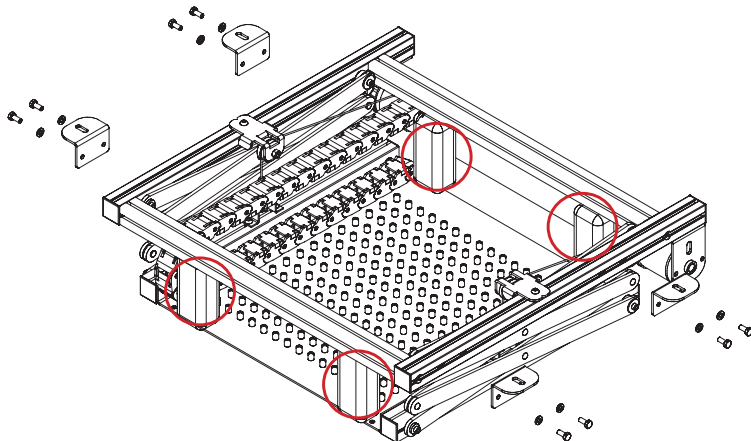

Do not remove the transport safety protection until the ceiling lift has been mounted. The spacers ensure the required tension of the wire ropes.

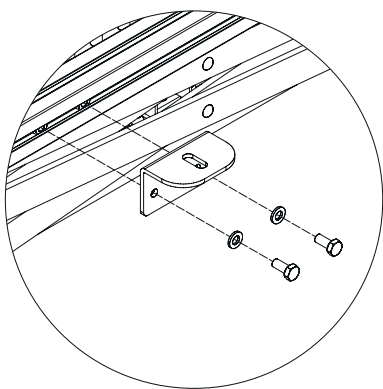

### Ceiling Installation

Attach the L brackets (A) to the frame profiles. Use the appropriate screws and washers. The nuts are already in the frame profiles (left and right).

## Installation

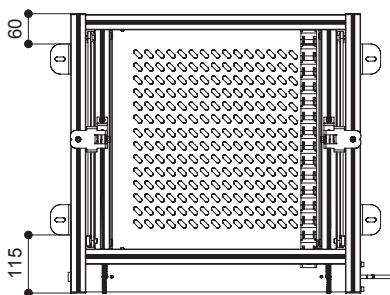

For a safe installation, it is recommended to position the L brackets similar as per the illustration. We assume in this manual that the installation is to a flat and horizontal ceiling. Please use a spirit level to ensure a horizontal installation.

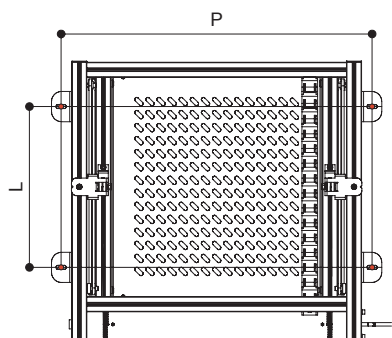

Measure and mark the position of the mounting points on the ceiling. The ceiling should be clean and flat.

Drill the four holes into the ceiling fitting your screws and wall plugs (not supplied). We recommend:  $\varnothing$  8mm

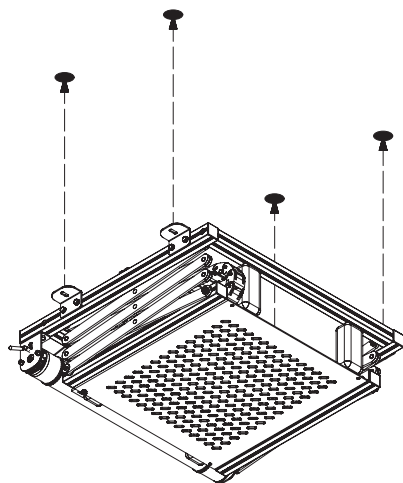

Mount the upper frame profile onto the ceiling.

Please verify that the lift is perfectly horizontal to ensure silent and safe movement.



## Installation

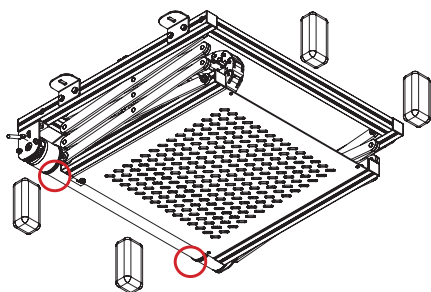

Once the lift has been mounted on the ceiling, remove the transport safety protection.

## Electrical connection

### Wall switch

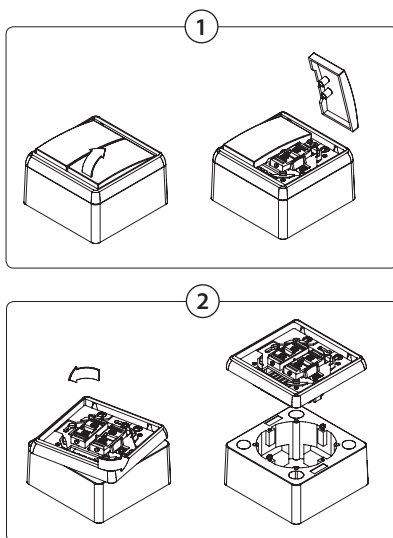
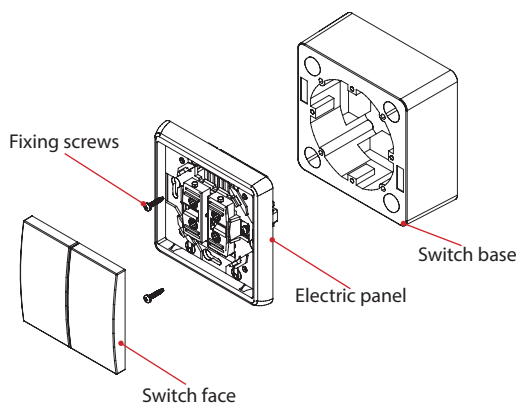

- 1 Remove the up / down switch face by pulling it upwards. Please do not use any tools to avoid causing damage
- 2 If necessary, loosen the screws, turn the switch face and remove it from the electric panel of the switch

The wall switch can be used with the provided switch base (A) or the electric panel can be flush mounted to the wall (B).

## Electrical connection

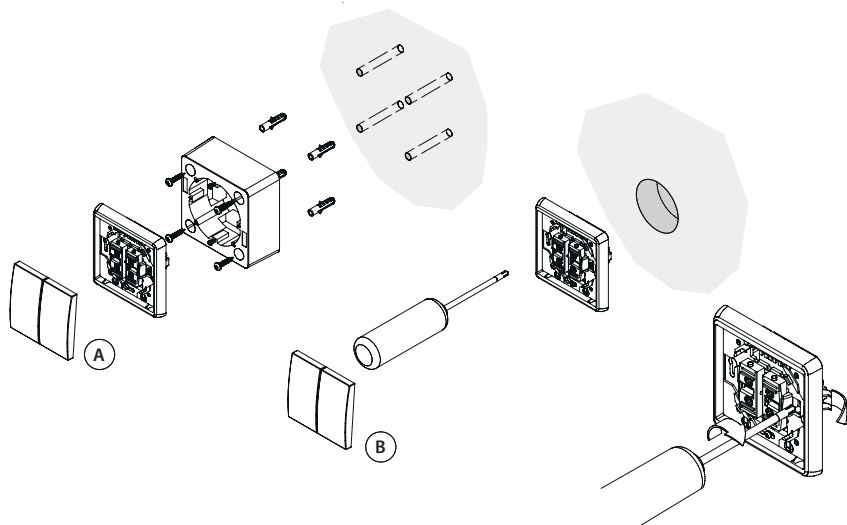

Select the power cable in accordance with power consumption of the lift. The cable should be protected against high temperatures, oils, sharp edges and being crushed by other components. The following illustration shows the electrical connection to the supplied wall switch.

- 1: Blue (Neutral)
- 2: Brown (Live)
- 3: Black (Live)
- ⊕: Yellow/green (Earth)

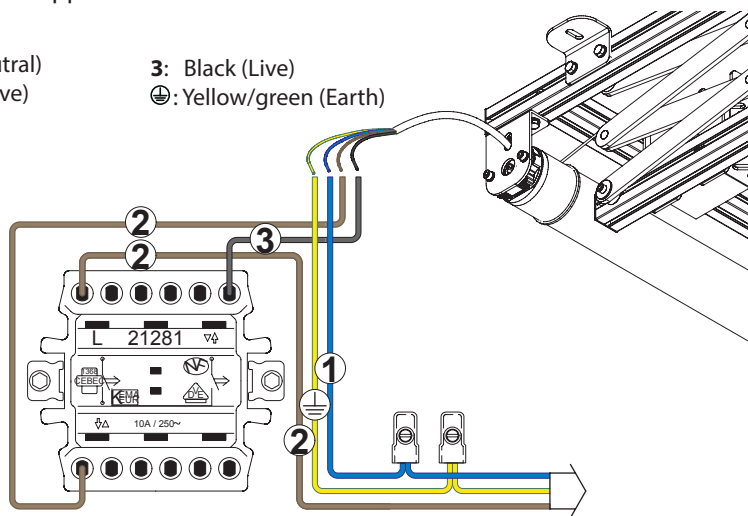

Installation and maintenance work may only be carried out by qualified personnel with technical and electrical expertise.

## Setting up the stop positions

You can adjust the stop position points with the allen key adjusting points to meet your requirements. Please carry out this step with the lift **ONLY** without the projector or ceiling tile attached.



### Upper Stop Position (when projector is in ceiling)

PLEASE NOTE: The upper stop position comes supplied in its highest position and being moved higher could seriously damage the lift.

To lower the upper stop position and get the ceiling tile level with the ceiling you must turn the rear adjuster clockwise. If you have lowered the lift too much then you can turn the adjuster anticlockwise to make it stop higher. Please adjust in very small increments and test the progress after every adjustment by operating the lift.

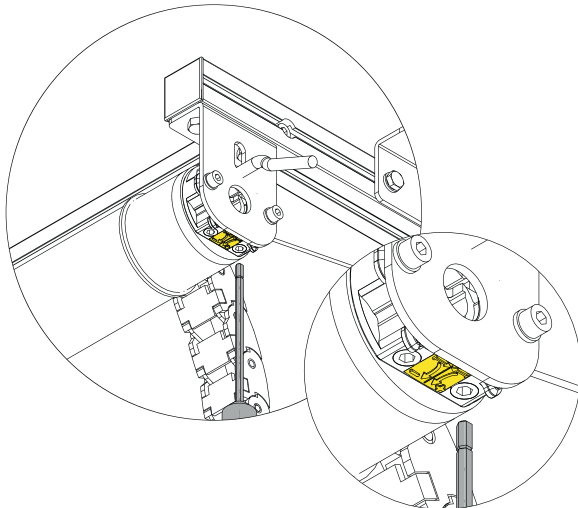
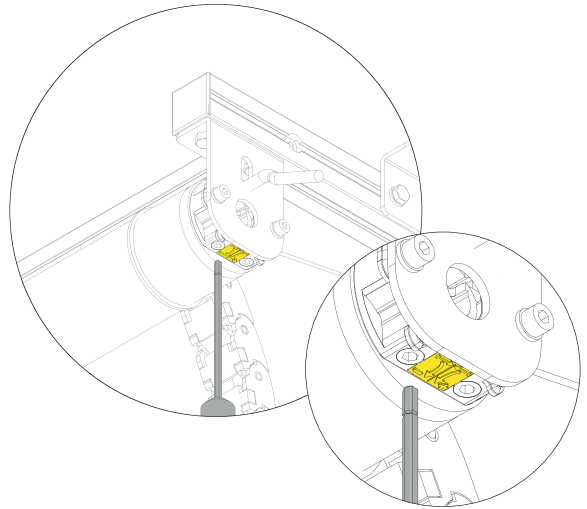

### Lower Stop Position (when projector is down)

To make the lift stop higher when the projector is down, turn the front adjuster clockwise. Or if you need to make the lift drop to a lower position – turn the front adjuster anticlockwise. Again, please adjust in very small increments and test the progress after every adjustment by operating the lift.

## Installation of the projector

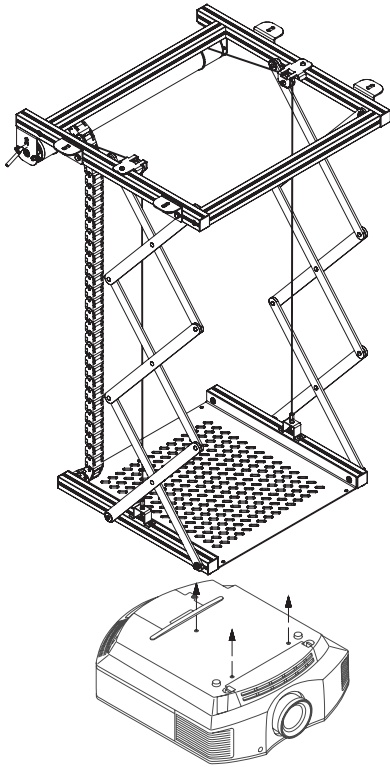

When you mount the projector to the lift, the lift has to be completely extended. Attach the projector to the profiles using appropriate screws (not supplied).

**Please ensure that the projector is installed with the centre of gravity in the centre of the lift.**

Please ensure that the projector is aligned completely horizontal using a spirit level to check.

Group together the cables into the plastic spiral cable management system (K). Please ensure that it does not get caught in the scissor joint or motor shaft when the lift is moving.

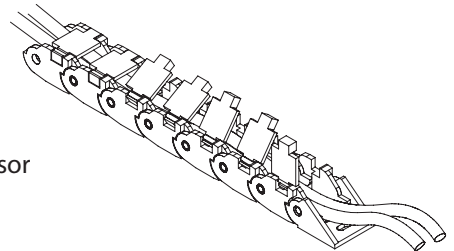

### **Danger:**

Only flexible cables should be used. Do not use cables that cannot be bent easily. Only attach cables when the lift is fully extended.

## Installation of the ceiling tile

First attach the four sliding brackets (D) to the lower right and left frame profiles of the ceiling lift. Use the hex head screws (I) and screw them into the nuts already on the frame profiles.

Attach the threaded rods (E) to the mounting brackets using the nuts (F). If necessary, you can shorten the threaded rods as required.

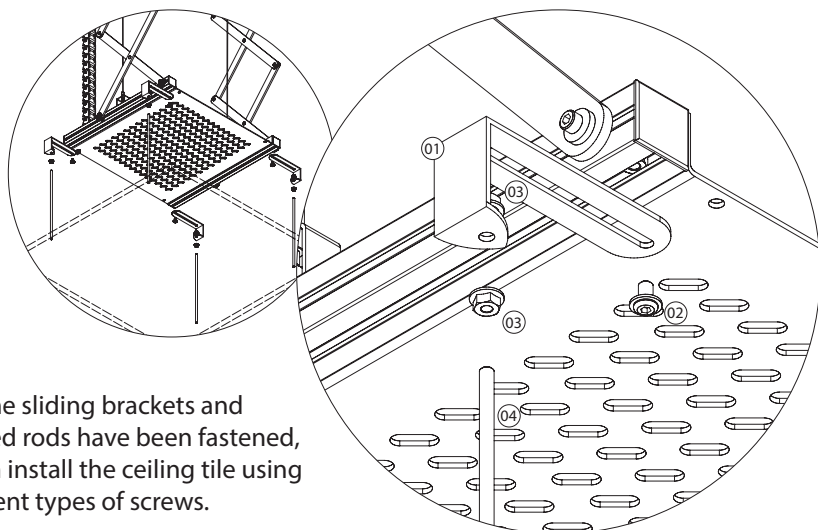

Once the sliding brackets and threaded rods have been fastened, you can install the ceiling tile using 2 different types of screws.

Visible screw	Invisible screw
Drill four holes in the ceiling plate. The diameter should not exceed that of the threaded sleeves. Insert the threaded sleeves (G) into the plate from below and then screw them onto the threaded rods, securing the ceiling tile to the lift safely.	Drill a small blind hole in the ceiling tile and screw in the self-tapping screw (H). If using a soft tile, the screw can be fixed in directly. Attach the ceiling tile to the threaded rods safely ensuring it is secure.



**Danger:**  
The ceiling tile must not weigh more than 2kg.

---

## Disposal

The disposal of the components must be carried out in accordance with the laws of the country in which the ceiling lift has been installed.

The EC directives must be observed:

- 91 / 156 / CEE waste
- 91 / 689 / CEE hazardous waste
- 94 / 62 / CE packaging and packaging waste

---

## Maintenance and repair

The ceiling lift should be subject to a safety check every six months. Only in this way can a safe and smooth operation be ensured.

The following points should be checked:

- Extending and retracting functions work properly without rubbing or delays.
- The steel ropes and their plastic coating should not be damaged.
- The projector lift should be fixed firmly to the ceiling.
- The end positions should be set correctly and the lift should be switched off when fully extended.
- The screws for fixing the steel ropes must be firmly tightened.
- The screws for fixing the projector must be tightened.

The results of the six-monthly check must be documented.

## Maintenance and repair

Date			Notes
Day	Month	Year	
Positive result			
Negative result			
			Signature

Date			Notes
Day	Month	Year	
Positive result			
Negative result			
			Signature

## Maintenance and repair

Date			Notes
Day	Month	Year	
Positive result			
Negative result			
			Signature

Date			Notes
Day	Month	Year	
Positive result			
Negative result			
			Signature