

UMB202

User Guide

IMPORTANT: Please read this User Guide to obtain important information on installing and using your product in a safe manner, as well as registering your product for future service. Warranty information contained in this User Guide will describe your limited coverage from ViewSonic® Corporation, which is also found on our web site at <http://www.viewsonic.com> in English, or in specific languages using the Regional selection box of our website.

Model No. VS19887
P/N: UMB202

Thank you for choosing ViewSonic®

As a world-leading provider of visual solutions, ViewSonic® is dedicated to exceeding the world's expectations for technological evolution, innovation, and simplicity. At ViewSonic®, we believe that our products have the potential to make a positive impact in the world, and we are confident that the ViewSonic® product you have chosen will serve you well.

Once again, thank you for choosing ViewSonic®!

Safety Precautions

Please read the following **Safety Precautions** before you start using the device.

- Keep this user guide in a safe place for later reference.
- Read all warnings and follow all instructions.
- To prevent damage, avoid any physical pressure, vibration, or immersion during transportation, possession, or installation of the product.
- Always place the product on a flat, stable surface.
- Avoid contacting any liquids, gas, or corrosive materials with the shell of the product.
- This product has no parts which can be repaired by the user. Any damage caused by the user's own disassembly is not covered by warranty.
- Electromagnetic fields at specific frequencies may affect the image of machine.

Contents

Safety Precautions.....	3
Introduction	6
Package Contents	6
Product Overview	7
Remote Control	8
Installing the Camera.....	10
Wall Mounting.....	10
VB-WMK-002 Mounting	11
Mounting UMB202 and VB-WMK-002 onto an IFP	12
Making Connections	13
Connecting to Power	13
Power Adapter (DC IN)	13
Ethernet (Power over Ethernet).....	13
Connecting to External Devices	14
USB Connection.....	15
Appendix.....	16
Specifications.....	16
Camera	16
USB	16
Input/Output Interface	16
General.....	17
Audio	17
Compatibility List.....	18
LED Indicators.....	20
Troubleshooting	21
Maintenance.....	22
General Precautions.....	22
Cleaning the Camera Lens.....	22
Cleaning the Case	22

Regulatory and Service Information	23
Compliance Information.....	23
FCC Compliance Statement.....	23
CE Conformity for European Countries.....	24
Declaration of RoHS2 Compliance.....	25
Indian Restriction of Hazardous Substances	26
Product Disposal at End of Product Life	26
Copyright Information	27
Customer Service	28
Limited Warranty	29
Mexico Limited Warranty.....	32

Introduction

Package Contents

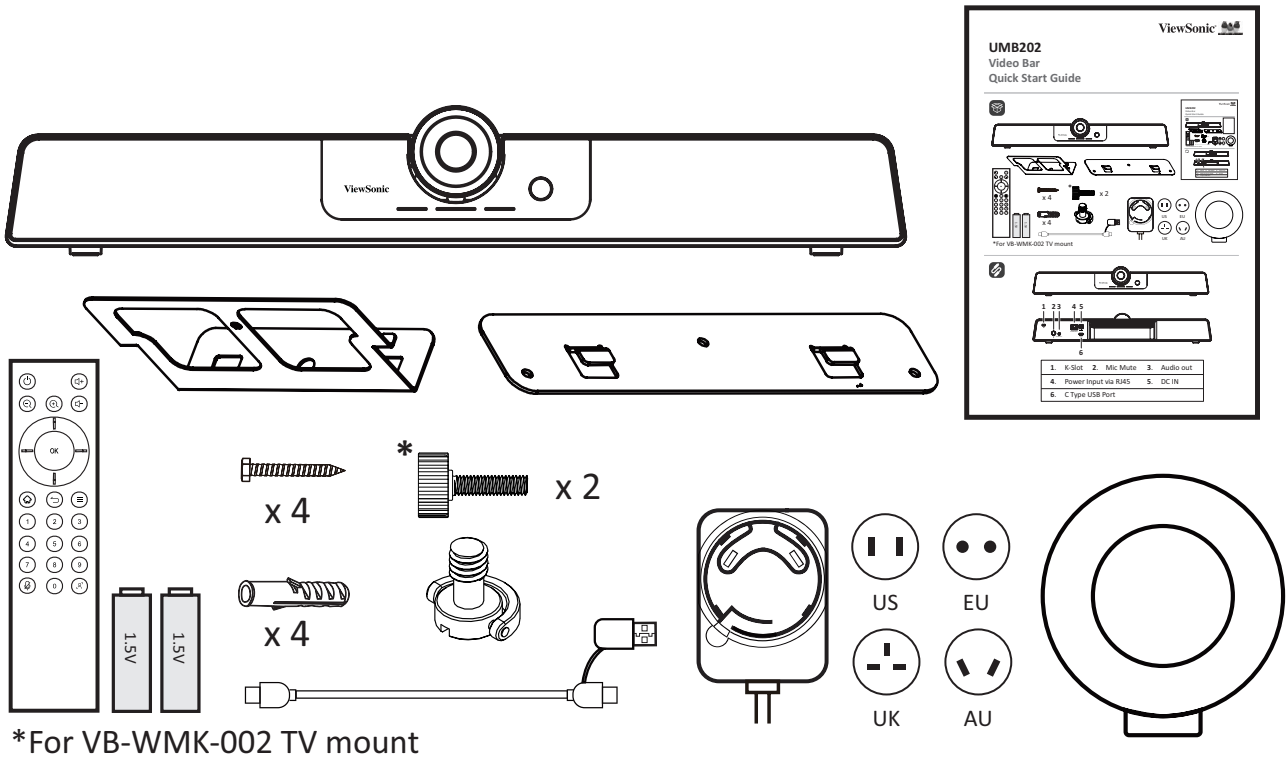

- UMB202
- Remote Control
- AAA Batteries x 2
- Wall Mounting Kit with Anchors and Screws
- TV Mount Screws
- USB Type C Cable with USB Type A Adapter
- Power Adapter with US/EU/UK/AU plug adapters
- Lens Cover
- Quick Start Guide

Product Overview

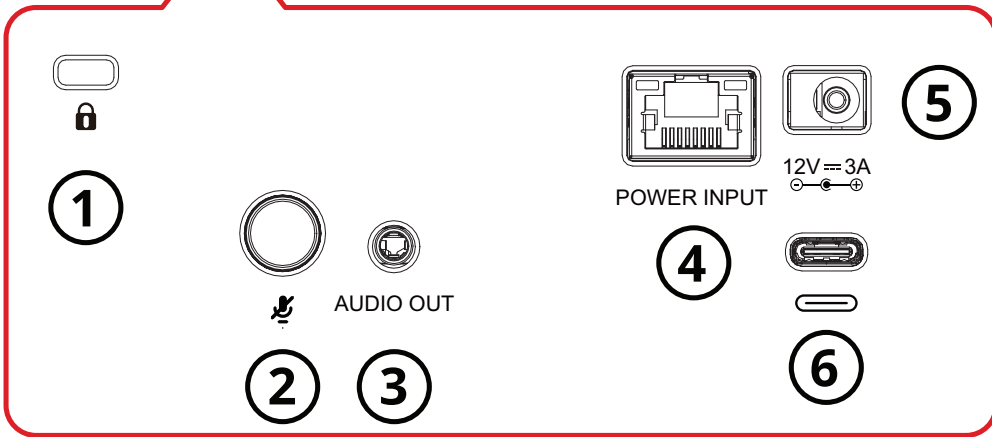
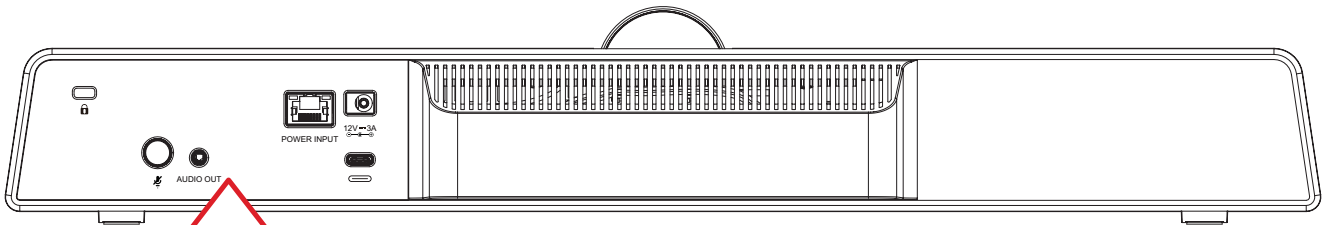
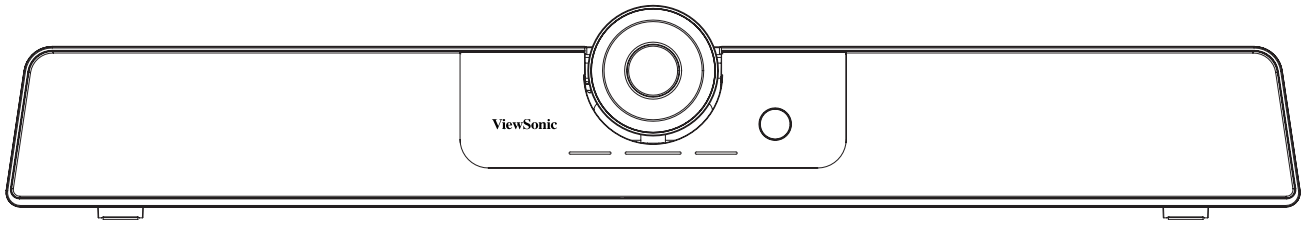

- 1. Security Slot
- 2. Mic Mute
- 3. Audio Out
- 4. Power Input (RJ45)
- 5. DC IN
- 6. USB Type C

NOTE: The RJ45 port only supports Power over Ethernet.

Remote Control

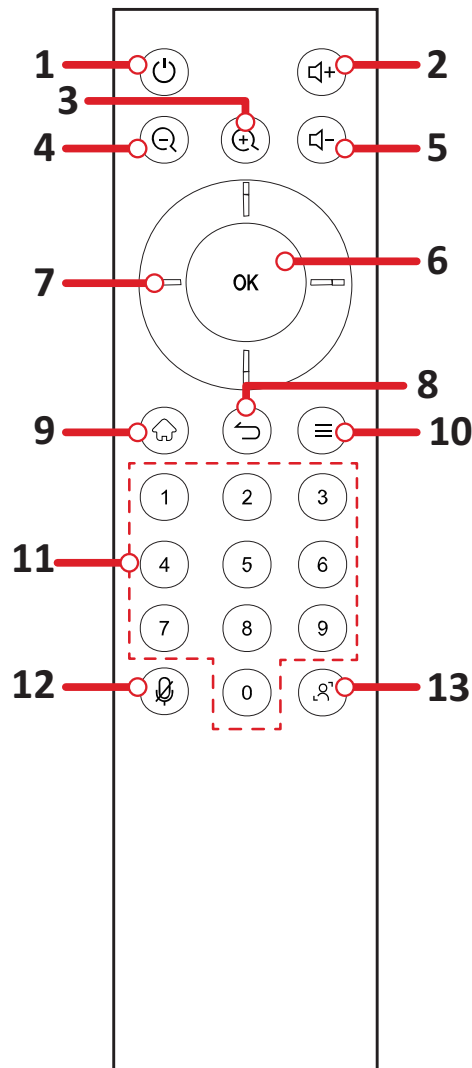

Number	Button	Description
1	Power On/Standby	Turn on the UMB202, or put into standby.
2	Volume Up	Increase the volume level.
3	Digital Zoom In	Increase the zoom level.
4	Digital Zoom Out	Decrease the zoom level.
5	Volume Down	Decrease the volume level.
6	OK (Confirm)	Confirm selection.
7	Directional	Adjust settings.
8		<i>No Function</i>
9		<i>No Function</i>
10		<i>No Function</i>
11	Number Pad	Press and hold a number for three seconds to save the image position to the pressed number.
12	Microphone Mute	Disable the microphone.
13	Framing Mode Adjust	Change the Framing Mode (Manual/Auto Framing and Voice Tracking/Voice Tracking Only).

Replacing the Batteries of the Remote Control

1. Remove the cover on the rear of the remote control.
2. Insert two “AAA” batteries, ensuring the “+” symbol on the battery matches the “+” on the battery post.
3. Replace the cover by aligning it with the slot on the remote control and snapping the latch shut.

NOTE:

- Avoid leaving the remote control or batteries in excessive heat or humidity.
- Always dispose of old batteries in an environmentally friendly way. Contact your local government for more information on how to dispose of batteries safely.
- Remove the batteries if the remote control will not be in use for an extended period of time.
- It is recommended that you do not mix battery types.

Installing the Camera

Wall Mounting

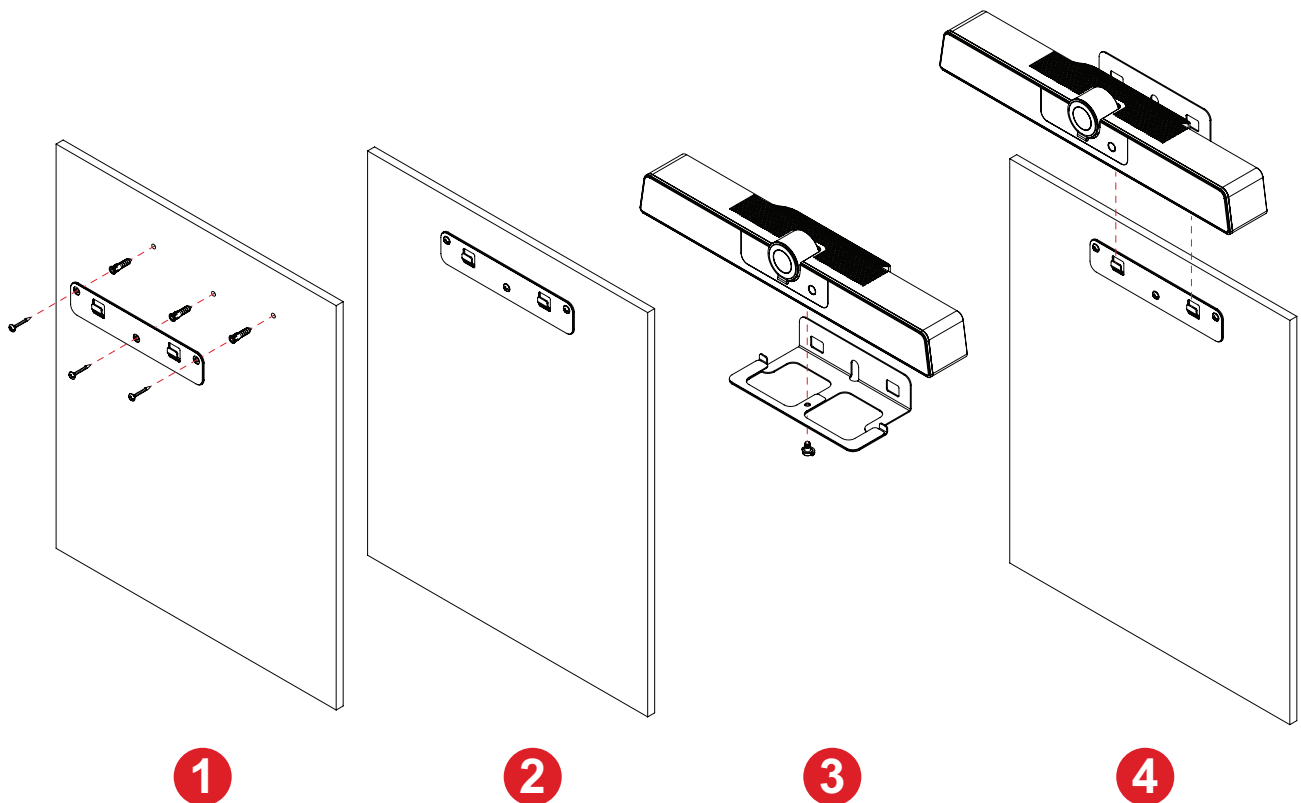

1. Pre-drill three holes into the wall and install the three wall anchors.
2. Align the wall bracket with the three anchors and secure the wall bracket with the three bracket screws.
3. Secure the camera to the mounting plate.
4. Attach the mounting plate to the wall bracket to complete the installation.

NOTE: When installing the camera, please note that there is a dimensional tolerance of 3%. It's advisable to manually measure the size and the distance between the users and the camera prior to final installation.

VB-WMK-002 Mounting

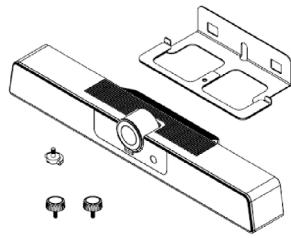

UMB202

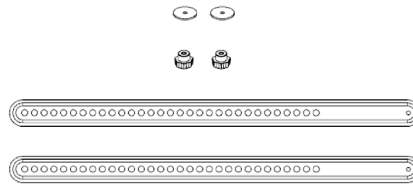

VB-WMK-002

NOTE: Some parts are optional accessories included in other ViewSonic products. Please refer to our website for more information.

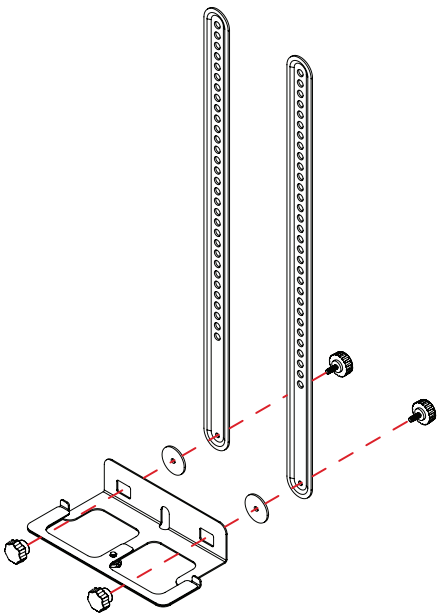

1

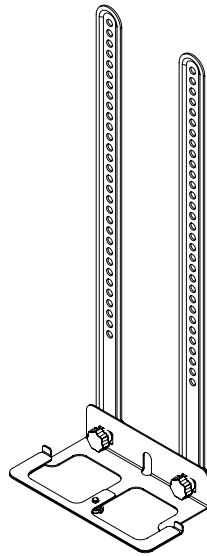

2

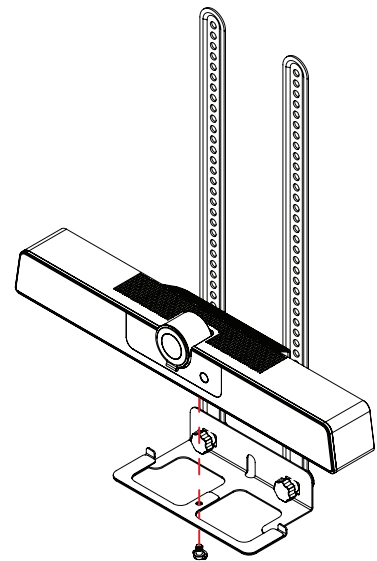

3

NOTE: The mounting plate and screws are included as accessories with UMB202.

1. Line up the mounting plate with the VB-WMK-002.
2. Attach the mounting plate to the VB-WMK-002 with the screws.
3. Secure the camera to the mounting plate.
4. For more information, refer to the VB-WMK-002 user guide.

NOTE: When installing the camera, please note that there is a dimensional tolerance of 3%. It's advisable to manually measure the size and the distance between the users and the camera prior to final installation.

Mounting UMB202 and VB-WMK-002 onto an IFP

After installing the UMB202 onto the VB-WMK-002, it can be set on an IFP as shown in the image below.

On the Top

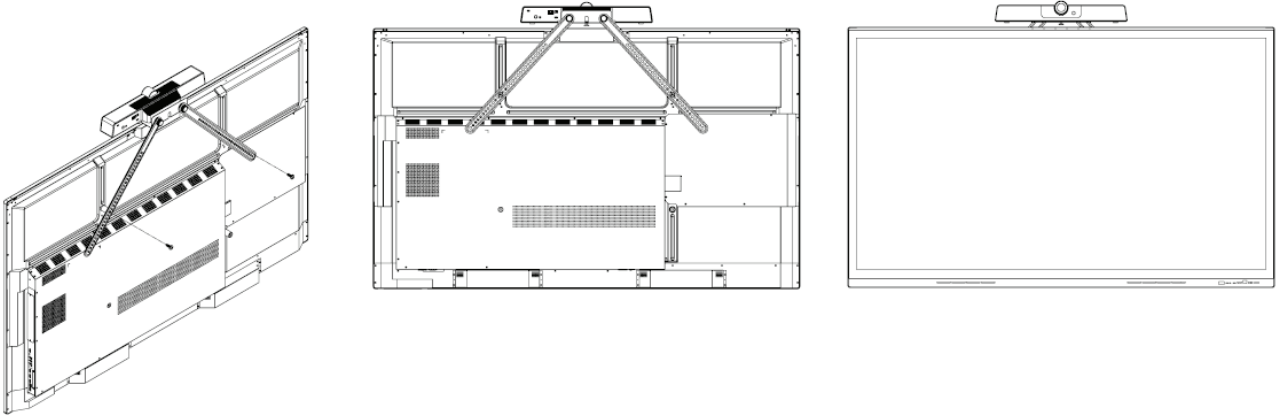

On the Bottom

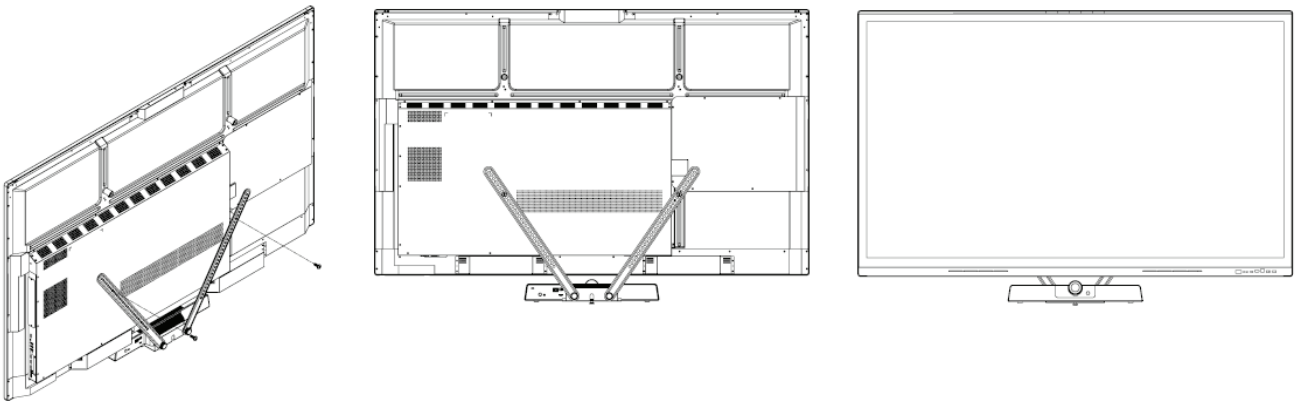

NOTE: Please refer to the Compatibility List on page 18 or contact our local service provider for more information.

Making Connections

Connecting to Power

Power Adapter (DC IN)

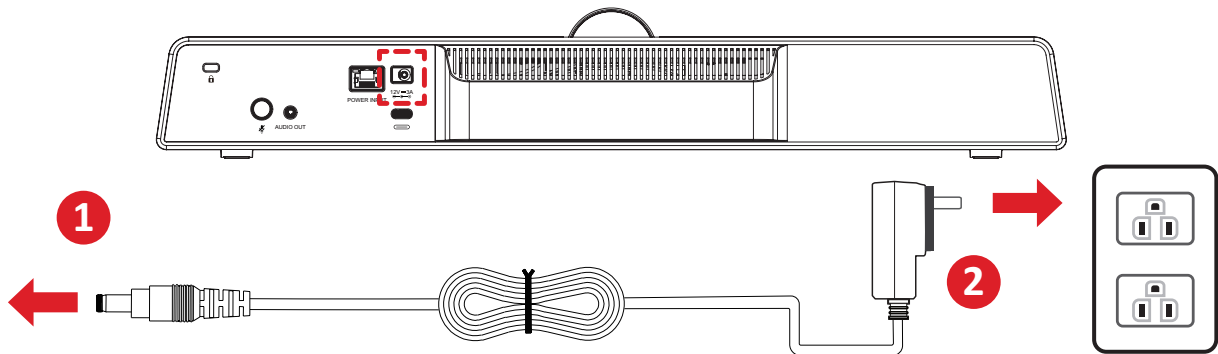

1. Connect the power cord to the DC IN jack at the rear of the camera.
2. Plug the power cord plug into a power outlet.

NOTE: The power adapter includes four different plug faces.

Ethernet (Power over Ethernet)

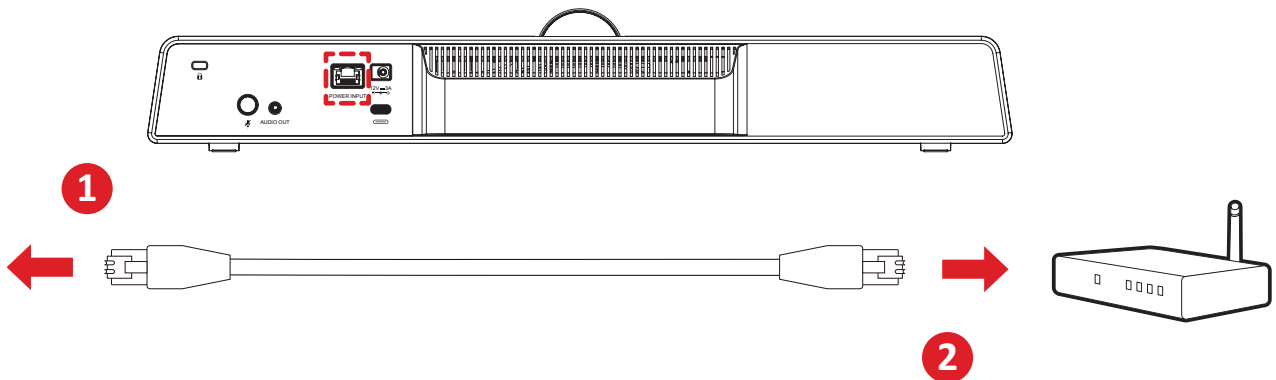

1. Connect the Ethernet cable to the RJ45 port at the rear of the camera.
2. Plug the other end of the Ethernet cable into an Ethernet injector or similar equipment.

Connecting to External Devices

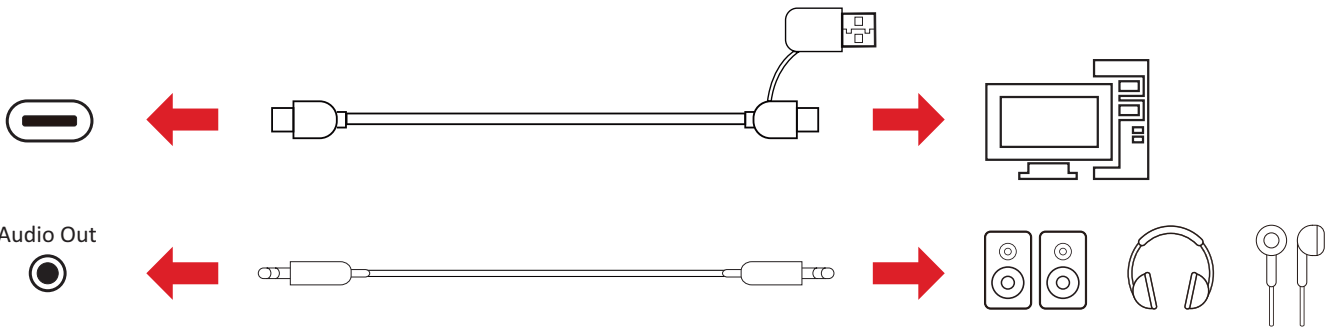
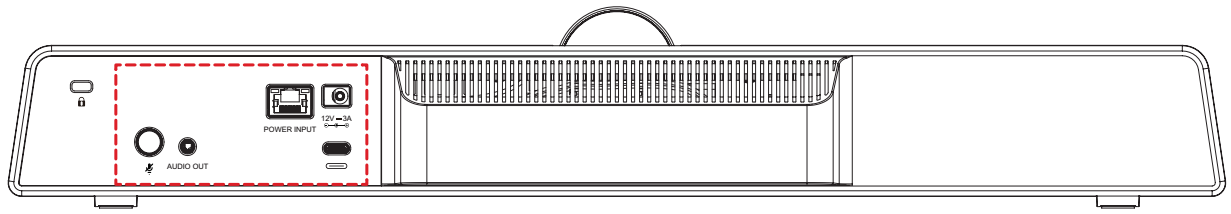

NOTE: Ensure the camera (UMB202) is the default video and audio output device when being used.

USB Connection

Connect one end of the USB cable to the camera's USB port. Then, plug the other end into a USB port on your PC, Interactive Flat Panel (IFP), or Conference PC (MPC310-W31-TU).

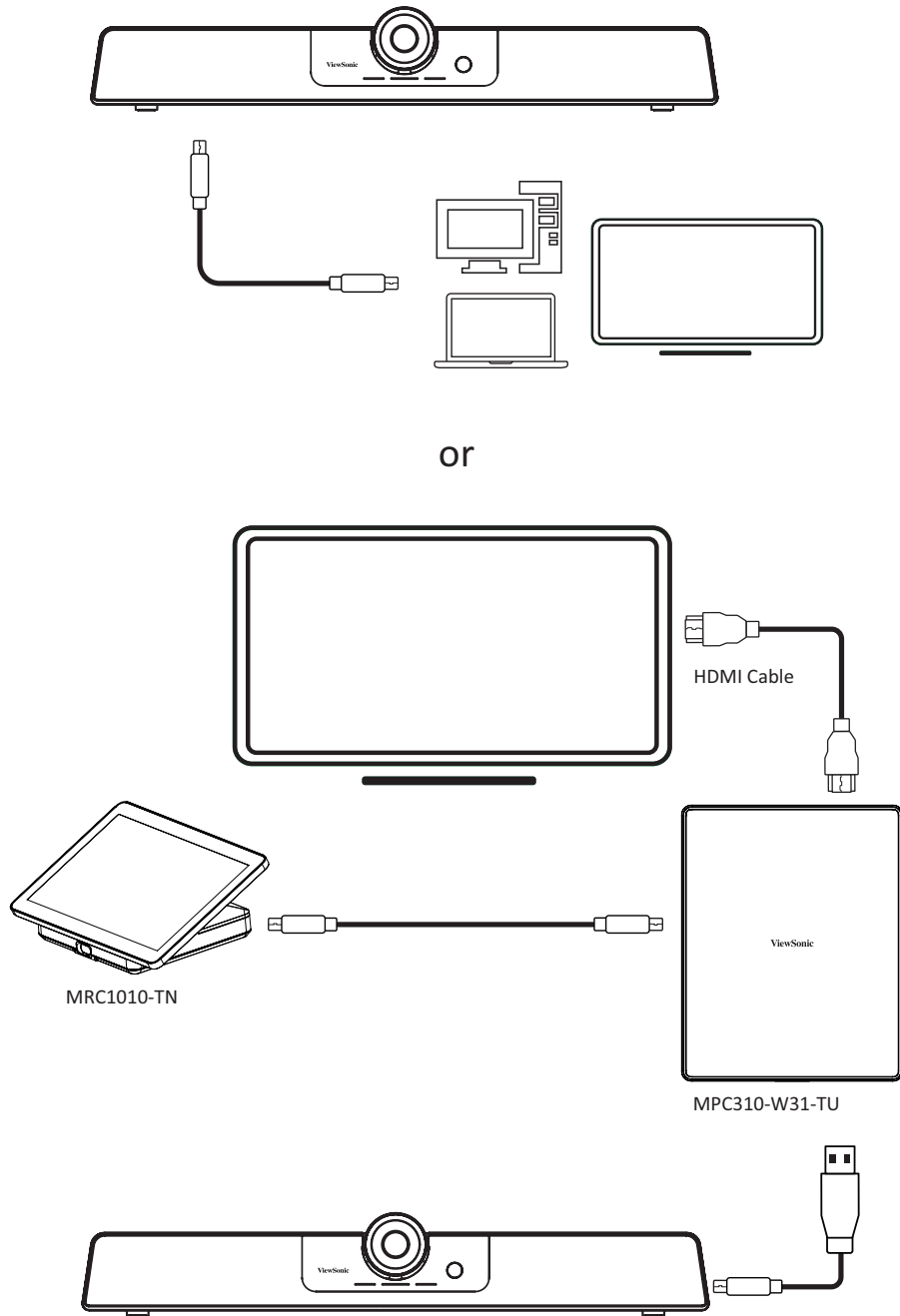

NOTE:

- The RJ45 port only supports Power over Ethernet.
- Refer to the ViewSonic MPC310-W31-TU Conference PC and MRC1010-TN Touch Console user manual for detailed settings of ViewSonic MTR (Microsoft Teams Rooms).

Appendix

Specifications

Camera

Item	Specifications
Sensor	IMX577 1/2.3 inch, CMOS, 12M pixel
Scanning Mode	Progressive
Lens Mount	2G5P
Lens FOV	117.8° (DFOV), 109° (HFOV), 74.4° (VFOV)
Minimal Illumination	50 lux
Shutter	No
White Balance	Automatic (Meets Teams certification standard)
Digital Noise Reduction	2DNR, 3DNR
Backlight Compensation	Support WDR
Digital Zoom	5x
Video S/N	44db (Meets Teams certification standard)

USB

Item	Specifications
Connection type	USB 3.0, downward compatible with USB 2.0 (USB 3.0 for C to A adaptor)
Color / Compression	MJPEG / YUY2 / H.264 / NV12
Video Format (Resolution)	4K @ 30 fps, 1080p @ 30 fps, 720p @ 30fps, etc.
USB Audio	16 kHz sampling rate
USB Video Communication Protocol	UVC 1.1
UVC PTZ control	Support (Control via Remote control)
UAC	Support (Version 1.0)

Input/Output Interface

Item	Specifications
USB Interface	1 x (USB 3.0, Type C)
Audio Out	1 x (3.5 mm)
Power	1 x (DC 2.0)
RJ45	1 x (Power over Ethernet only)
Power button	1
PIR Sensor	Yes

General

Item	Specifications	
Control Method	2.4G Remote Control	
Installation Method	Desktop, Wall, TV and other display devices.	
Operating Temperature	0° C ~ 40° C	
	32° F ~ 104° F	
Storage Temperature	-40° C ~ 60° C	
	-40°F ~ 140° F	
Dimensions (W x H x D)	462 x 76 x 93 mm	
	18.2" x 3.0" x 3.7"	
Net Weight	1.05 kg	
	2.31 lbs	
Power Adapter	Input	AC100~240V, 1A 50/60 Hz
	Output	DC12V, 3A
Power Consumption	< 6W	

NOTE: Damage may occur if you use a different adapter. Please confirm the input voltage, output voltage and output power is consistent to your original adapter before you use the new adapter.

Audio

Item	Specifications
Module	1 x Treble module 1 x Mid-bass module
Rated Power (Maximum)	8W
Impedance	6 Ohm
Response	20 Hz~20,000 Hz
Mean of SPL (1W, m)	80db SPL
Type	Microphone array (Beamforming, 6 elements)
Pickup range	8 meters pickup range

Compatibility List

Below is a compatibility list for VB-WMK-002 and UMB202.

Model	Top Installation Support	Bottom Installation Support
CDE4330	✓	✓
CDE5530	✓	✓
CDE6530	✓	✓
CDE7530	✓	✓
CDE8630	✓	✓
CDE9830	✓	✗
IFP92UW	✓	✓
CDE92UW	✓	✓
IFP6553	✓	✓
IFP7553	✓	✓
IFP8653	✓	✓
IFP55G1	✓	✓
IFP65G1	✓	✓
IFP75G1	✓	✗
IFP86G1	✓	✗
IFP105S	✗	✗
IFP5550-3	✓	✓
IFP6550-3	✓	✓
IFP7550-3	✓	✗
IFP8650-3	✓	✓
IFP9850-3	✓	✗
IFP9850-4	✓	✗
IFP5550-5	✓	✓

Model	Top Installation Support	Bottom Installation Support
IFP6550-5	✓	✓
IFP7550-5	✓	✗
IFP8650-5	✓	✓
IFP6552-1A/B/BH	✓	✓
IFP6552-1C	✓	✓
IFP7552-1A/B/BH	✓	✗
IFP7552-1C	✓	✗
IFP8652-1A/B/BH	✓	✗
IFP8652-1C	✓	✗
IFP6552-2	✓	✓
IFP7552-2	✓	✓
IFP8652-2	✓	✓
IFP6532	✓	✓
IFP7532	✓	✗
IFP8632	✓	✓
IFP6533	✓	✓
IFP7533	✓	✗
IFP8633	✓	✓
IFP6562	✓	✓
IFP7562	✓	✗
IFP8662	✓	✓

LED Indicators

Light	Description
Blue Light Pulsing from Left to Right	Device is booting up.
Solid White	Device is fully booted and ready for use.
Solid Aqua Blue (Cyan)	Device is in use - both the microphone and camera are on.
Solid White	Microphone is on; the camera is off.
Solid Red	The microphone is off; the camera is on.
Solid Red	Both the microphone and camera are off.
White Light Increasing/ Decreasing in Length from Left to Right	Increase or decrease the volume level.
White Light Pulsing from Left to Right	Firmware update is in progress.
12 LED Dot and a Blue Dot that Lights Up for One Second	Voice direction indicator. The 12 LED dots indicate 180° coverage, while the blue light indicates the direction of the sound source.

Troubleshooting

Problem or Issue	Possible Solutions
No power	<ul style="list-style-type: none">• Make sure you have turned on the device by pressing the Power button on the remote control.• Make sure the power cord is properly and securely connected to the device and power outlet.• Plug another electrical device into the power outlet to verify that the outlet is supplying power.
The video image displayed by the camera is shaking	<ul style="list-style-type: none">• Ensure the camera is securely installed and stable.• Check for any nearby equipment that may be giving off vibrations.

Maintenance

General Precautions

- Make sure the camera is turned off and the power cable is unplugged from the power outlet if it will not be used for an extended period of time.
- Avoid lens should avoid bright objects (e.g., sunlight), and unstable light conditions.
- Do not use the camera around facilities that can transmit high-power radio waves (e.g., television station).

Cleaning the Camera Lens

- Wipe the camera lens with a clean, soft, lint-free cloth. This removes dust and other particles.

Cleaning the Case

- Use a soft, dry cloth to clean.

Disclaimer

- ViewSonic® does not recommend the use of any ammonia or alcohol-based cleaners on the device or case. Some chemical cleaners have been reported to damage the device and/or case.
- ViewSonic® will not be liable for damage resulting from use of any ammonia or alcohol-based cleaners.

Regulatory and Service Information

Compliance Information

This section addresses all connected requirements and statements regarding regulations. Confirmed corresponding applications shall refer to nameplate labels and relevant markings on the unit.

FCC Compliance Statement

This device complies with part 15 of FCC Rules. Operation is subject to the following two conditions: (1) this device may not cause harmful interference, and (2) this device must accept any interference received, including interference that may cause undesired operation. This equipment has been tested and found to comply with the limits for a Class B digital device, pursuant to part 15 of the FCC Rules.

These limits are designed to provide reasonable protection against harmful interference in a residential installation. This equipment generates, uses, and can radiate radio frequency energy, and if not installed and used in accordance with the instructions, may cause harmful interference to radio communications. However, there is no guarantee that interference will not occur in a particular installation. If this equipment does cause harmful interference to radio or television reception, which can be determined by turning the equipment off and on, the user is encouraged to try to correct the interference by one or more of the following measures:

- Reorient or relocate the receiving antenna.
- Increase the separation between the equipment and receiver.
- Connect the equipment into an outlet on a circuit different from that to which the receiver is connected.
- Consult the dealer or an experienced radio/TV technician for help.

Industry Canada Statement

CAN ICES-003(B) / NMB-003(B)

CE Conformity for European Countries

CE The device complies with the EMC Directive 2014/30/EU, Low Voltage Directive 2014/35/EU.

The following information is only for EU-member states:

The mark shown to the right is in compliance with the Waste Electrical and Electronic Equipment Directive 2012/19/EU (WEEE). The mark indicates the requirement NOT to dispose of the equipment as unsorted municipal waste, but use the return and collection systems according to local law.



Batteries may not be disposed in trash or household recycling collection bins intended to receive other non-hazardous waste and/or recyclable materials. Please use the public collection system to return, recycle, or treat them in compliance with the local regulations.



Declaration of RoHS2 Compliance

This product has been designed and manufactured in compliance with Directive 2011/65/EU of the European Parliament and the Council on restriction of the use of certain hazardous substances in electrical and electronic equipment (RoHS2 Directive) and is deemed to comply with the maximum concentration values issued by the European Technical Adaptation Committee (TAC) as shown below:

Substance	Proposed Maximum Concentration	Actual Concentration
Lead (Pb)	0.1%	< 0.1%
Mercury (Hg)	0.1%	< 0.1%
Cadmium (Cd)	0.01%	< 0.01%
Hexavalent Chromium (Cr6 ⁺)	0.1%	< 0.1%
Polybrominated biphenyls (PBB)	0.1%	< 0.1%
Polybrominated diphenyl ethers (PBDE)	0.1%	< 0.1%
Bis(2-ethylhexyl) phthalate (DEHP)	0.1%	< 0.1%
Butyl benzyl phthalate (BBP)	0.1%	< 0.1%
Dibutyl phthalate (DBP)	0.1%	< 0.1%
Diisobutyl phthalate (DIBP)	0.1%	< 0.1%

Certain components of products as stated above are exempted under the Annex III of the RoHS2 Directives as noted below:

- Copper alloy containing up to 4% lead by weight.
- Lead in high melting temperature type solders (i.e. lead-based alloys containing 85% by weight or more lead).
- Electrical and electronic components containing lead in a glass or ceramic other than dielectric ceramic in capacitors, e.g. piezoelectronic devices, or in a glass or ceramic matrix compound.
- Lead in dielectric ceramic capacitors for rated voltage of 125V AC or 250V DC or higher.

Indian Restriction of Hazardous Substances

Restriction on Hazardous Substances statement (India). This product complies with the “India E-waste Rule 2011” and prohibits use of lead, mercury, hexavalent chromium, polybrominated biphenyls or polybrominated diphenyl ethers in concentrations exceeding 0.1 weight % and 0.01 weight % for cadmium, except for the exemptions set in Schedule 2 of the Rule.

Product Disposal at End of Product Life

ViewSonic® respects the environment and is committed to working and living green. Thank you for being part of Smarter, Greener Computing. Please visit the ViewSonic® website to learn more.

USA & Canada:

<https://www.viewsonic.com/us/go-green-with-viewsonic>

Europe:

<https://www.viewsonic.com/eu/environmental-social-governance/recycle>

Taiwan:

<https://recycle.moenv.gov.tw/>

For EU users, please contact us for any safety/accident issue experienced with this product:

ViewSonic Europe Limited



Haaksbergweg 75
1101 BR Amsterdam
Netherlands



+31 (0) 650608655



EPREL@viewsoniceurope.com



<https://www.viewsonic.com/eu/>

Copyright Information

Copyright© ViewSonic® Corporation, 2024. All rights reserved.

Macintosh and Power Macintosh are registered trademarks of Apple Inc.

Microsoft, Windows, and the Windows logo are registered trademarks of Microsoft Corporation in the United States and other countries.

ViewSonic® and the three birds logo are registered trademarks of ViewSonic® Corporation.

VESA is a registered trademark of the Video Electronics Standards Association. DPMS, DisplayPort, and DDC are trademarks of VESA.

ENERGY STAR® is a registered trademark of the U.S. Environmental Protection Agency (EPA).

As an ENERGY STAR® partner, ViewSonic® Corporation has determined that this product meets the ENERGY STAR® guidelines for energy efficiency.

Disclaimer: ViewSonic® Corporation shall not be liable for technical or editorial errors or omissions contained herein; nor for incidental or consequential damages resulting from furnishing this material, or the performance or use of this product.

In the interest of continuing product improvement, ViewSonic® Corporation reserves the right to change product specifications without notice. Information in this document may change without notice.

No part of this document may be copied, reproduced, or transmitted by any means, for any purpose without prior written permission from ViewSonic® Corporation.

Customer Service

For technical support or product service, see the table below or contact your reseller.

NOTE: You will need the product's serial number.

Country/ Region	Website	Country/ Region	Website
Asia Pacific & Africa			
Australia	www.viewsonic.com/au/	Bangladesh	www.viewsonic.com/bd/
中国 (China)	www.viewsonic.com.cn	香港 (繁體中文)	www.viewsonic.com/hk/
Hong Kong (English)	www.viewsonic.com/hk-en/	India	www.viewsonic.com/in/
Indonesia	www.viewsonic.com/id/	Israel	www.viewsonic.com/il/
日本 (Japan)	www.viewsonic.com/jp/	Korea	www.viewsonic.com/kr/
Malaysia	www.viewsonic.com/my/	Middle East	www.viewsonic.com/me/
Myanmar	www.viewsonic.com/mm/	Nepal	www.viewsonic.com/np/
New Zealand	www.viewsonic.com/nz/	Pakistan	www.viewsonic.com/pk/
Philippines	www.viewsonic.com/ph/	Singapore	www.viewsonic.com/sg/
臺灣 (Taiwan)	www.viewsonic.com/tw/	ประเทศไทย	www.viewsonic.com/th/
Việt Nam	www.viewsonic.com/vn/	South Africa & Mauritius	www.viewsonic.com/za/
Americas			
United States	www.viewsonic.com/us	Canada	www.viewsonic.com/us
Latin America	www.viewsonic.com/la		
Europe			
Europe	www.viewsonic.com/eu/	France	www.viewsonic.com/fr/
Deutschland	www.viewsonic.com/de/	Қазақстан	www.viewsonic.com/kz/
Россия	www.viewsonic.com/ru/	España	www.viewsonic.com/es/
Türkiye	www.viewsonic.com/tr/	Україна	www.viewsonic.com/ua/
United Kingdom	www.viewsonic.com/uk/		

Limited Warranty

ViewSonic® Display

What the warranty covers:

ViewSonic® warrants its products to be free from defects in material and workmanship during the warranty period. If a product proves to be defective in material or workmanship during the warranty period, ViewSonic® will, at its sole option, and as your sole remedy, repair or replace the product with a similar product. Replacement Product or parts may include remanufactured or refurbished parts or components. The repair or replacement unit or parts or components will be covered by the balance of the time remaining on the customer's original limited warranty and the warranty period will not be extended. ViewSonic® provides no warranty for any third-party software whether included with the product or installed by the customer, installation of any unauthorized hardware parts or components (e.g. Projector Lamps). (Please refer to: "What the warranty excludes and does not cover" section).

How long the warranty is effective:

ViewSonic® displays are warranted for between 1 and 3 years, depending on your country of purchase, for all parts including the light source and for all labor from the date of the first consumer purchase.

Who the warranty protects:

This warranty is valid only for the first consumer purchaser.

What the warranty excludes and does not cover:

- Any product on which the serial number has been defaced, modified, or removed.
- Damage, deterioration, or malfunction resulting from:
 - » Accident, misuse, neglect, fire, water, lightning, or other acts of nature, unauthorized product modification, or failure to follow instructions supplied with the product.
 - » Repair or attempted repair by anyone not authorized by ViewSonic®
 - » Damage to or loss of any programs, data, or removable storage media.
 - » Normal wear and tear.
 - » Removal or installation of the product.
- Software or data loss occurring during repair or replacement.
- Any damage of the product due to shipment.

- Causes external to the product, such as electric power fluctuations or failure.
- Use of supplies or parts not meeting ViewSonic’s specifications.
- Failure of owner to perform periodic product maintenance as stated in the User Guide.
- Any other cause which does not relate to a product defect.
- Damage caused by static (non-moving) images displayed for lengthy periods of time (also referred to as image burn-in).
- Software - Any third-party software included with the product or installed by the customer.
- Hardware/Accessories/Parts/Components – Installation of any unauthorized hardware, accessories, consumable parts or components (e.g. Projector Lamps).
- Damage to, or abuse of, the coating on the surface of the display through inappropriate cleaning as described in the product User Guide.
- Removal, installation, and set-up service charges, including wall-mounting of the product.

How to get service:

- For information about receiving service under warranty, contact ViewSonic® Customer Support (Please refer to the “Customer Service” page). You will need to provide your product’s serial number.
- To obtain warranty service, you will be required to provide: (a) the original dated sales slip, (b) your name, (c) your address, (d) a description of the problem, and (e) the serial number of the product.
- Take or ship the product, freight prepaid, in the original container to an authorized ViewSonic® service center or ViewSonic®.
- For additional information or the name of the nearest ViewSonic® service center, contact ViewSonic®.

Limitation of implied warranties:

There are no warranties, express or implied, which extend beyond the description contained herein including the implied warranty of merchantability and fitness for a particular purpose.

Exclusion of damages:

ViewSonic's liability is limited to the cost of repair or replacement of the product. ViewSonic® shall not be liable for:

- Damage to other property caused by any defects in the product, damages based upon inconvenience, loss of use of the product, loss of time, loss of profits, loss of business opportunity, loss of goodwill, interference with business relationships, or other commercial loss, even if advised of the possibility of such damages.
- Any other damages, whether incidental, consequential or otherwise.
- Any claim against the customer by any other party.
- Repair or attempted repair by anyone not authorized by ViewSonic®.

Effect of state law:

This warranty gives you specific legal rights, and you may also have other rights which vary from state to state. Some states do not allow limitations on implied warranties and/or do not allow the exclusion of incidental or consequential damages, so the above limitations and exclusions may not apply to you.

Sales outside the U.S.A. and Canada:

For warranty information and service on ViewSonic® products sold outside of the U.S.A. and Canada, contact ViewSonic® or your local ViewSonic® dealer.

The warranty period for this product in mainland China (Hong Kong, Macao, and Taiwan Excluded) is subject to the terms and conditions of the Maintenance Guarantee Card.

For users in Europe and Russia, full details of warranty provided can be found at: <http://www.viewsonic.com/eu/> under "Support/Warranty Information".

Mexico Limited Warranty

ViewSonic® Display

What the warranty covers:

ViewSonic® warrants its products to be free from defects in material and workmanship, under normal use, during the warranty period. If a product proves to be defective in material or workmanship during the warranty period, ViewSonic® will, at its sole option, repair or replace the product with a like product. Replacement product or parts may include remanufactured or refurbished parts or components & accessories.

How long the warranty is effective:

ViewSonic® LCD displays are warranted for between 1 and 3 years, depending on your country of purchase, for all parts including the light source and for all labour from the date of the first consumer purchase.

Who the warranty protects:

This warranty is valid only for the first consumer purchaser.

What the warranty excludes and does not cover:

- Any product on which the serial number has been defaced, modified or removed.
- Damage, deterioration, or malfunction resulting from:
 - » Accident, misuse, neglect, fire, water, lightning, or other acts of nature, unauthorized product modification, unauthorized attempted repair, or failure to follow instructions supplied with the product.
 - » Causes external to the product, such as electrical power fluctuations or failure.
 - » Use of supplies or parts not meeting ViewSonic®'s specifications.
 - » Normal wear and tear.
 - » Any other cause which does not relate to a product defect.
- Any product exhibiting a condition commonly known as “image burn-in” which results when a static image is displayed on the product for an extended period of time.
- Removal, installation, insurance, and set-up service charges.

How to get service:

For information about receiving service under warranty, contact ViewSonic® Customer Support (Please refer to the attached “Customer Service” page). You will need to provide your product’s serial number, so please record the product information in the space provided below on your purchase for your future use. Please retain your receipt of proof of purchase to support your warranty claim.

For Your Records

Product Name: _____ Model Number: _____
Document Number: _____ Serial Number: _____
Purchase Date: _____ Extended Warranty Purchase? _____(Y/N)
If so, what date does warranty expire? _____

- To obtain warranty service, you will be required to provide (a) the original dated sales slip, (b) your name, (c) your address, (d) a description of the problem, and (e) the serial number of the product.
- Take or ship the product, in the original container packaging, to an authorized ViewSonic® service center.
- Round trip transportation costs for in-warranty products will be paid by ViewSonic®.

Limitation of implied warranties:

There are no warranties, express or implied, which extend beyond the description contained herein including the implied warranty of merchantability and fitness for a particular purpose.

Exclusion of damages:

ViewSonic®’s liability is limited to the cost of repair or replacement of the product. ViewSonic® shall not be liable for:

- Damage to other property caused by any defects in the product, damages based upon inconvenience, loss of use of the product, loss of time, loss of profits, loss of business opportunity, loss of goodwill, interference with business relationships, or other commercial loss, even if advised of the possibility of such damages.
- Any other damages, whether incidental, consequential or otherwise.
- Any claim against the customer by any other party.
- Repair or attempted repair by anyone not authorized by ViewSonic®.

Contact Information for Sales & Authorized Service (Centro Autorizado de Servicio) within Mexico:	
Name, address, of manufacturer and importers: México, Av. de la Palma #8 Piso 2 Despacho 203, Corporativo Interpalmas, Col. San Fernando Huixquilucan, Estado de México Tel: (55) 3605-1099 http://www.viewsonic.com/la/soporte/index.htm	
NÚMERO GRATIS DE ASISTENCIA TÉCNICA PARA TODO MÉXICO: 001.866.823.2004	
Hermosillo: Distribuciones y Servicios Computacionales SA de CV. Calle Juarez 284 local 2 Col. Bugambilias C.P: 83140 Tel: 01-66-22-14-9005 E-Mail: disc2@hmo.megared.net.mx	Villahermosa: Compumantenimientos Garantizados, S.A. de C.V. AV. GREGORIO MENDEZ #1504 COL, FLORIDA C.P. 86040 Tel: 01 (993) 3 52 00 47 / 3522074 / 3 52 20 09 E-Mail: compumantenimientos@prodigy.net.mx
Puebla, Pue. (Matriz): RENTA Y DATOS, S.A. DE C.V. Domicilio: 29 SUR 721 COL. LA PAZ 72160 PUEBLA, PUE. Tel: 01(52).222.891.55.77 CON 10 LINEAS E-Mail: datos@puebla.megared.net.mx	Veracruz, Ver.: CONEXION Y DESARROLLO, S.A DE C.V. Av. Americas # 419 ENTRE PINZÓN Y ALVARADO Fracc. Reforma C.P. 91919 Tel: 01-22-91-00-31-67 E-Mail: gacosta@qplus.com.mx
Chihuahua: Soluciones Globales en Computación C. Magisterio # 3321 Col. Magisterial Chihuahua, Chih. Tel: 4136954 E-Mail: Cefeo@soluglobales.com	Cuernavaca: Compusupport de Cuernavaca SA de CV Francisco Leyva # 178 Col. Miguel Hidalgo C.P. 62040, Cuernavaca Morelos Tel: 01 777 3180579 / 01 777 3124014 E-Mail: aquevedo@compusupportcva.com
Distrito Federal: QPLUS, S.A. de C.V. Av. Coyoacán 931 Col. Del Valle 03100, México, D.F. Tel: 01(52)55-50-00-27-35 E-Mail : gacosta@qplus.com.mx	Guadalajara, Jal.: SERVICRECE, S.A. de C.V. Av. Niños Héroes # 2281 Col. Arcos Sur, Sector Juárez 44170, Guadalajara, Jalisco Tel: 01(52)33-36-15-15-43 E-Mail: mmiranda@servicrece.com
Guerrero Acapulco: GS Computación (Grupo Sesicomp) Progreso #6-A, Colo Centro 39300 Acapulco, Guerrero Tel: 744-48-32627	Monterrey: Global Product Services Mar Caribe # 1987, Esquina con Golfo Pérsico Fracc. Bernardo Reyes, CP 64280 Monterrey N.L. México Tel: 8129-5103 E-Mail: aydeem@gps1.com.mx
MERIDA: ELECTROSER Av Reforma No. 403Gx39 y 41 Mérida, Yucatán, México CP97000 Tel: (52) 999-925-1916 E-Mail: rrrb@sureste.com	Oaxaca, Oax.: CENTRO DE DISTRIBUCION Y SERVICIO, S.A. de C.V. Murguía # 708 P.A., Col. Centro, 68000, Oaxaca Tel: 01(52)95-15-15-22-22 Fax: 01(52)95-15-13-67-00 E-Mail: gpotai2001@hotmail.com
Tijuana: STD Av Ferrocarril Sonora #3780 L-C Col 20 de Noviembr Tijuana, Mexico	FOR USA SUPPORT: ViewSonic® Corporation 381 Brea Canyon Road, Walnut, CA. 91789 USA Tel: 800-688-6688 E-Mail: http://www.viewsonic.com



ViewSonic®