

User Guide

Meeting

Instant Meeting

Introduction

After completing the [Quick Setup](#) in the MVC Rooms system, you can log in to your Skype account and use the Microsoft Teams Rooms System to start a meeting.

How to Use

You need to switch the system to Microsoft Teams mode (For more information, please refer to [Switch Account](#)).

Start a Meeting

Select **Meet** to start your meeting.

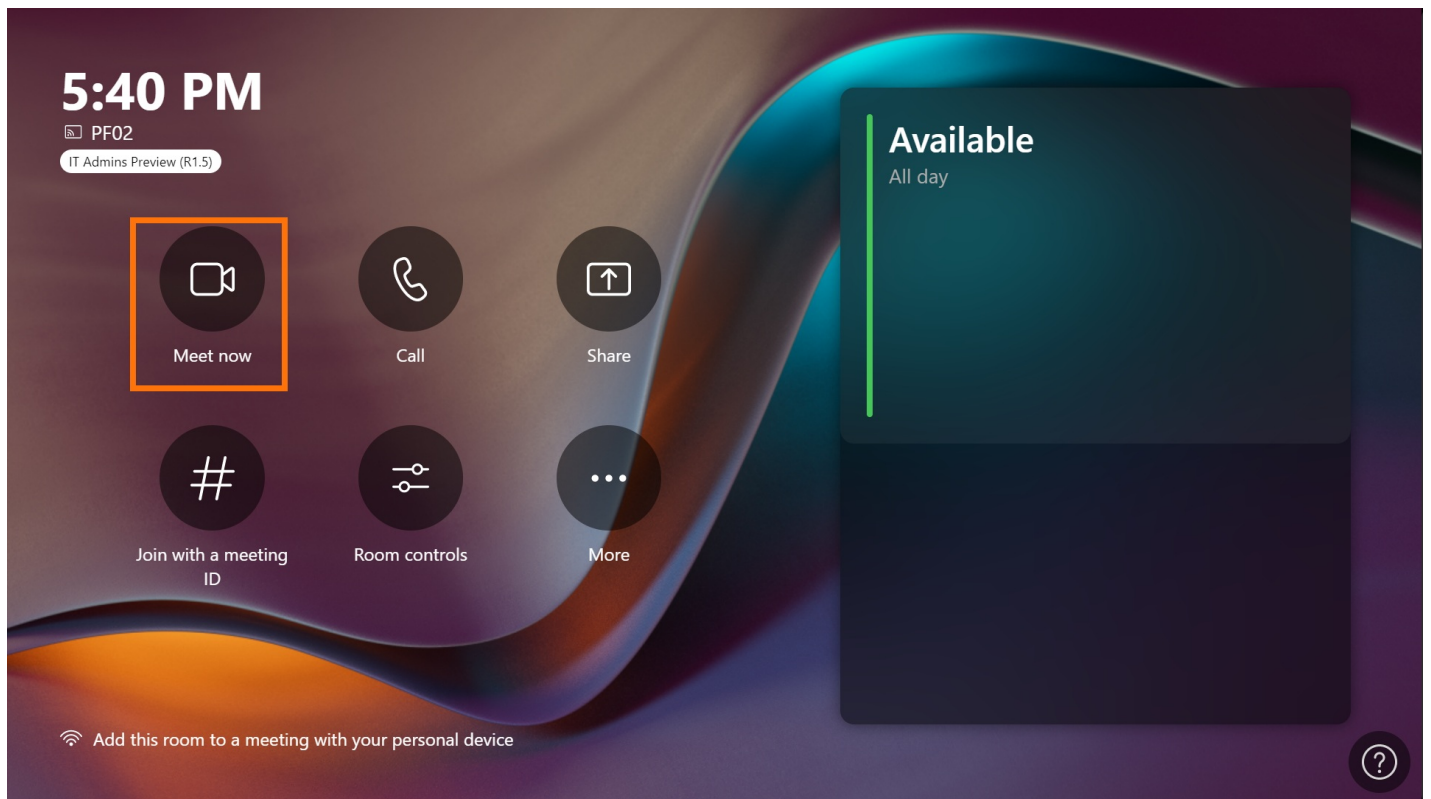

Invite other participants to join the meeting.

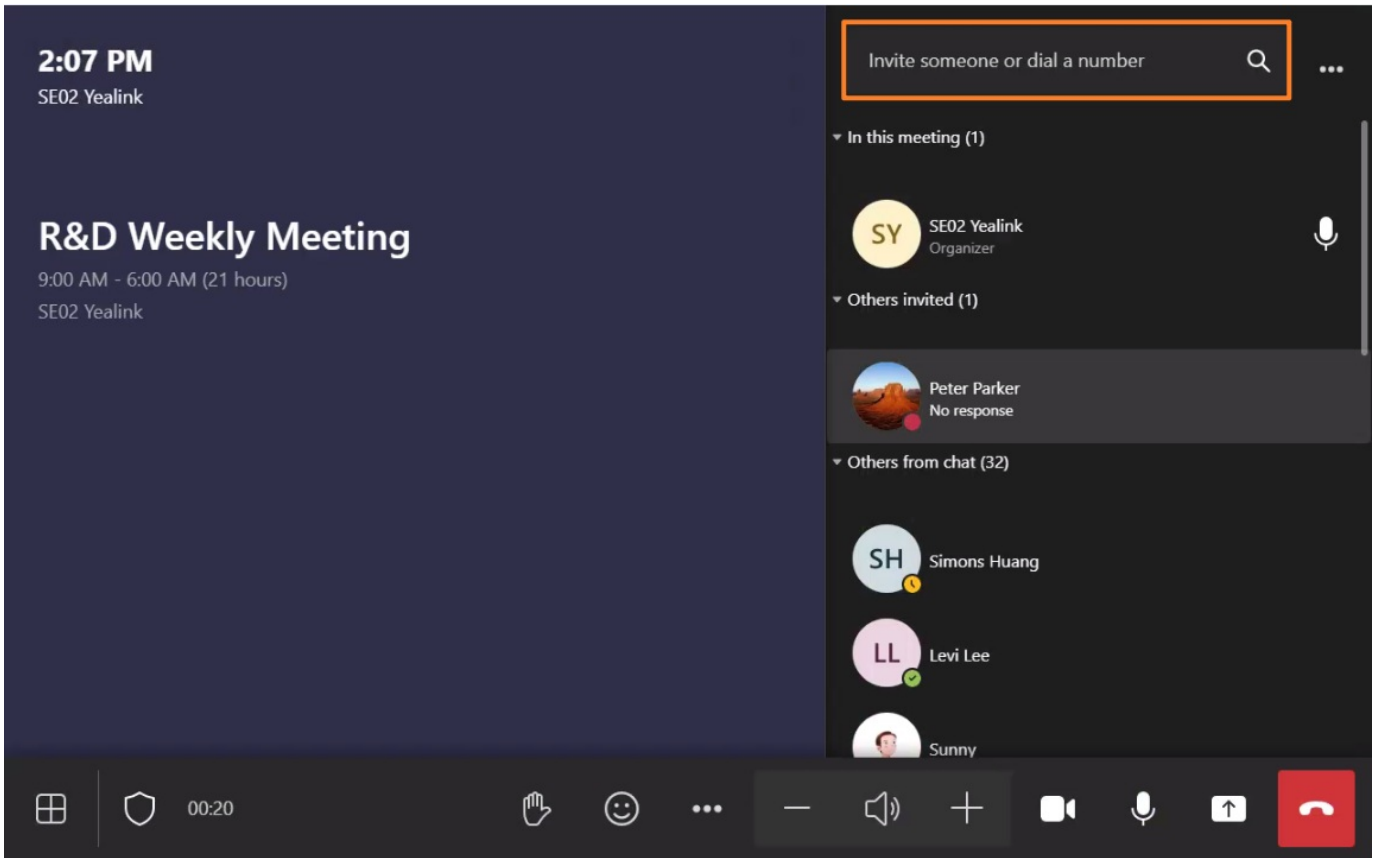

Call Someone to Join Meeting

1. Select **Call** to type a name or number (Tip: You can call multiple people simultaneously).
2. Select **Call** and wait for the other person to enter the meeting.

TIP
You can search for someone's name, number or email account.

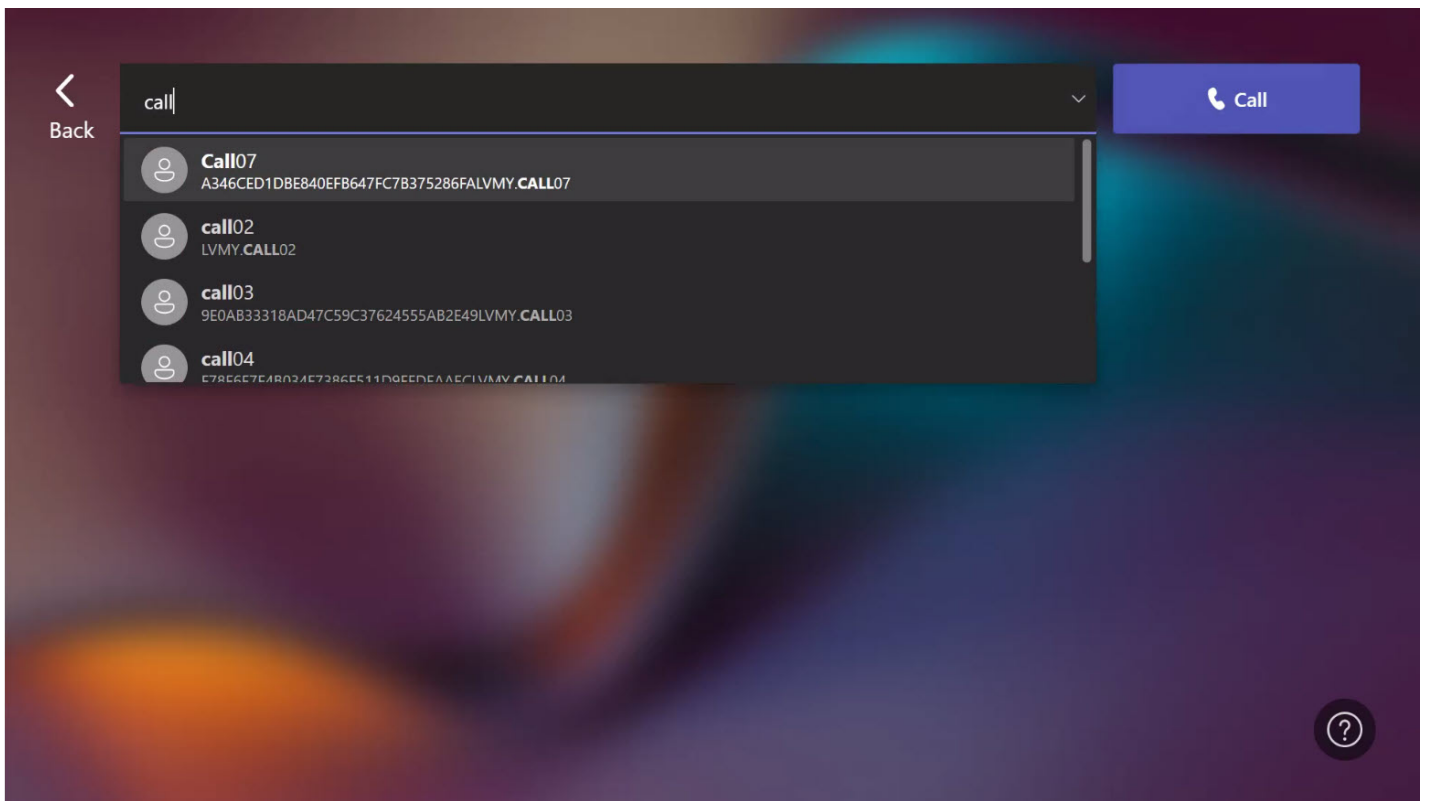
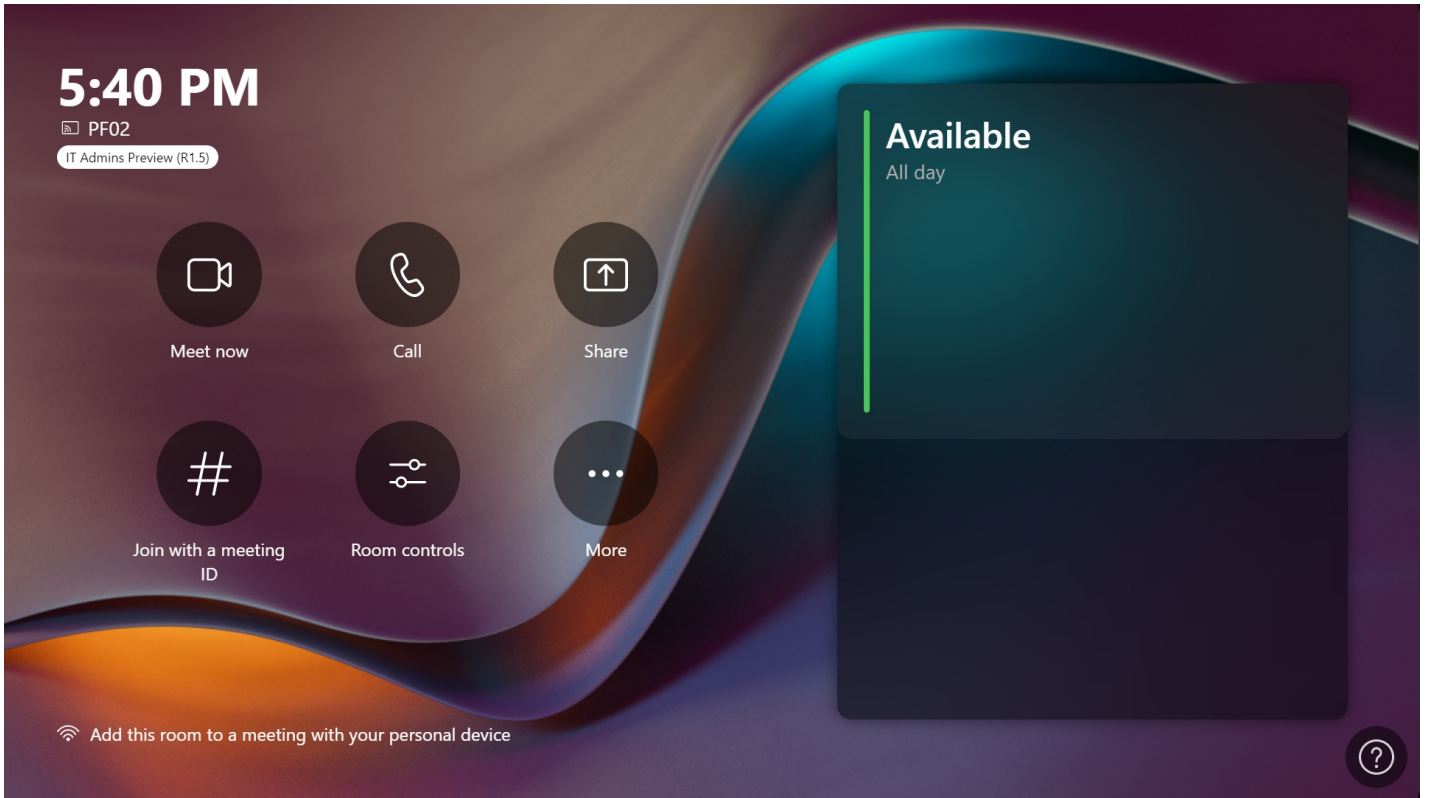

FAQ

How do I check my email account?

1. Go to **More > Settings**.
2. After entering the administrator password (default: sfb), you can view it in **Accounts**.

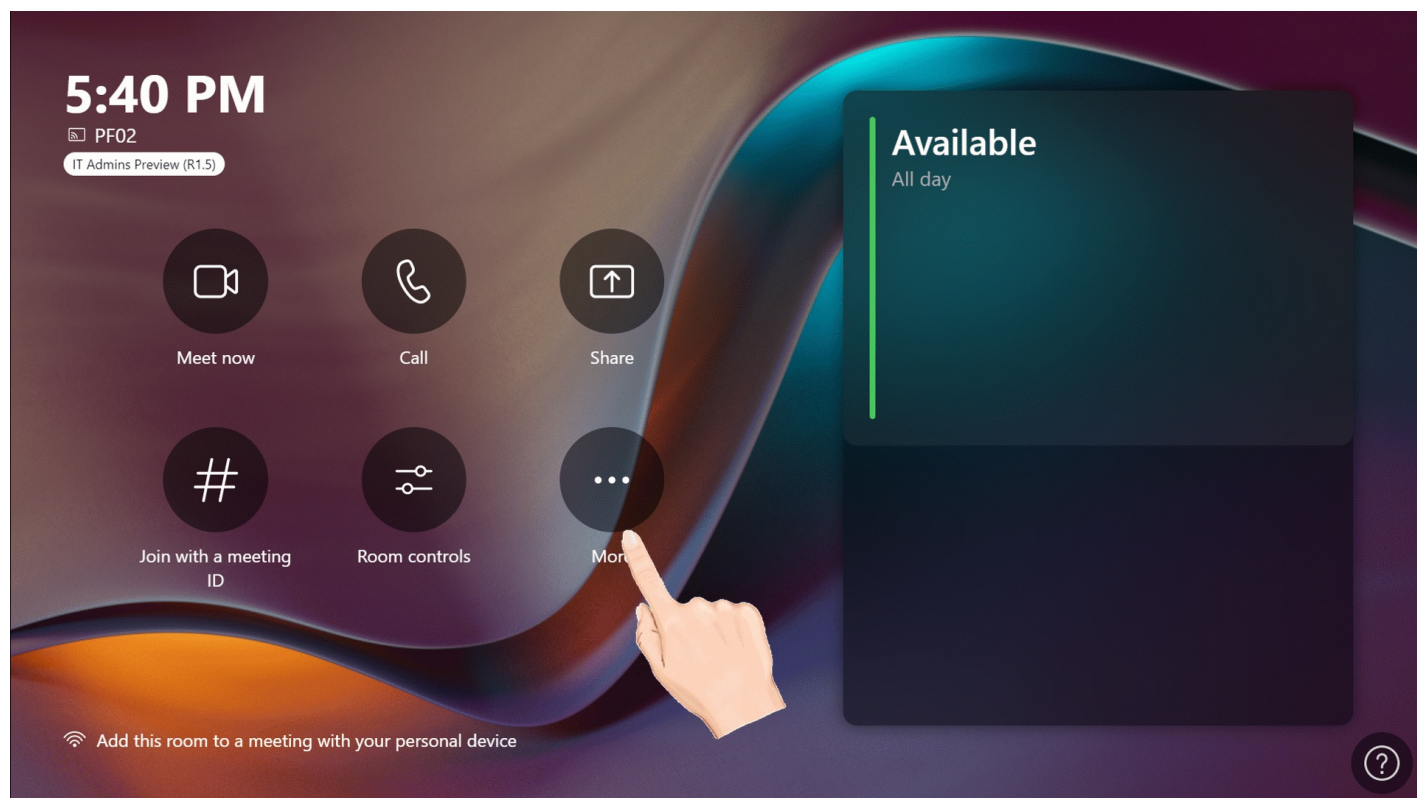

Does MVC support reserving a meeting? How to reverse a meeting?

The MVC Rooms system does not support scheduling a meeting but supports an instant meeting. If you want to reserve a Teams meeting, you can download the Teams client to reserve a meeting. Please refer to [Schedule a meeting in Teams](#) for more information.

Join Meeting

Introduction

You can use MTouch II /MTouch Plus to join meetings reserved by Microsoft Teams.

How to Use

Before you start: You need to switch the system to Microsoft Teams mode (For more information, please refer to [Switch Account](#)).

Join Scheduled Meetings

If you have been invited as a participant in a meeting, the home page will display the meeting information, and you can directly select **Join**.

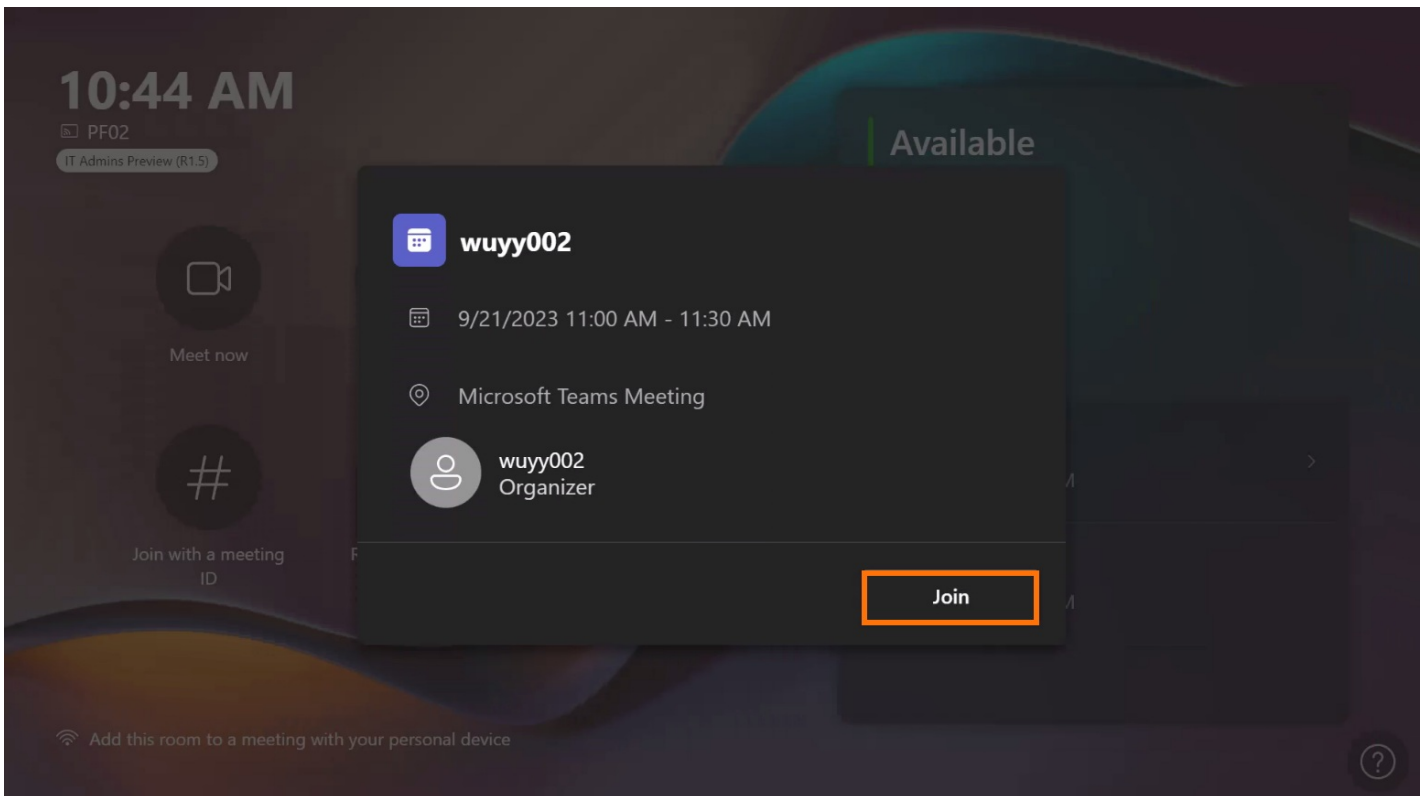
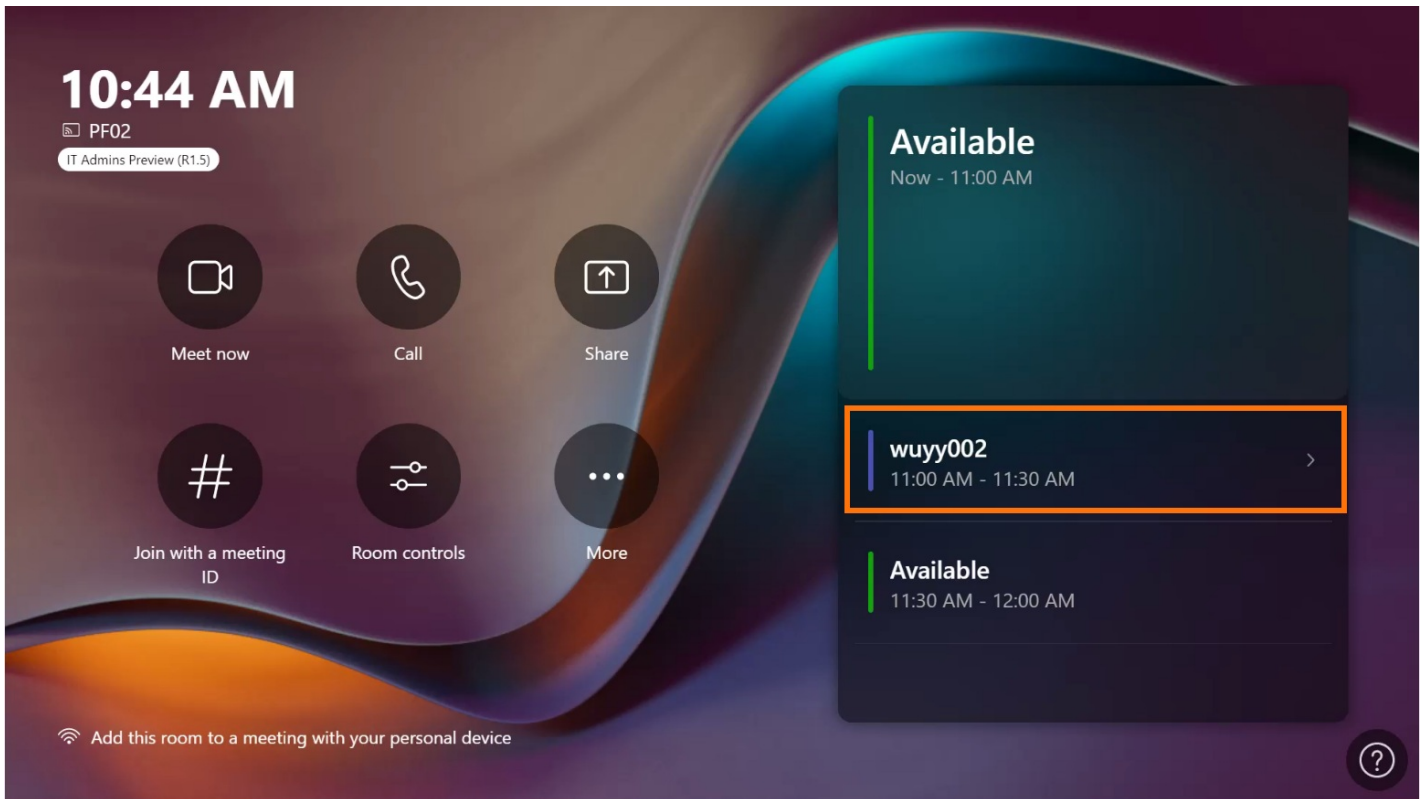

Join with Meeting ID

1. Click **Join with a Meeting ID**.
2. Enter the corresponding meeting ID and password.

3. Select **Join meeting**.

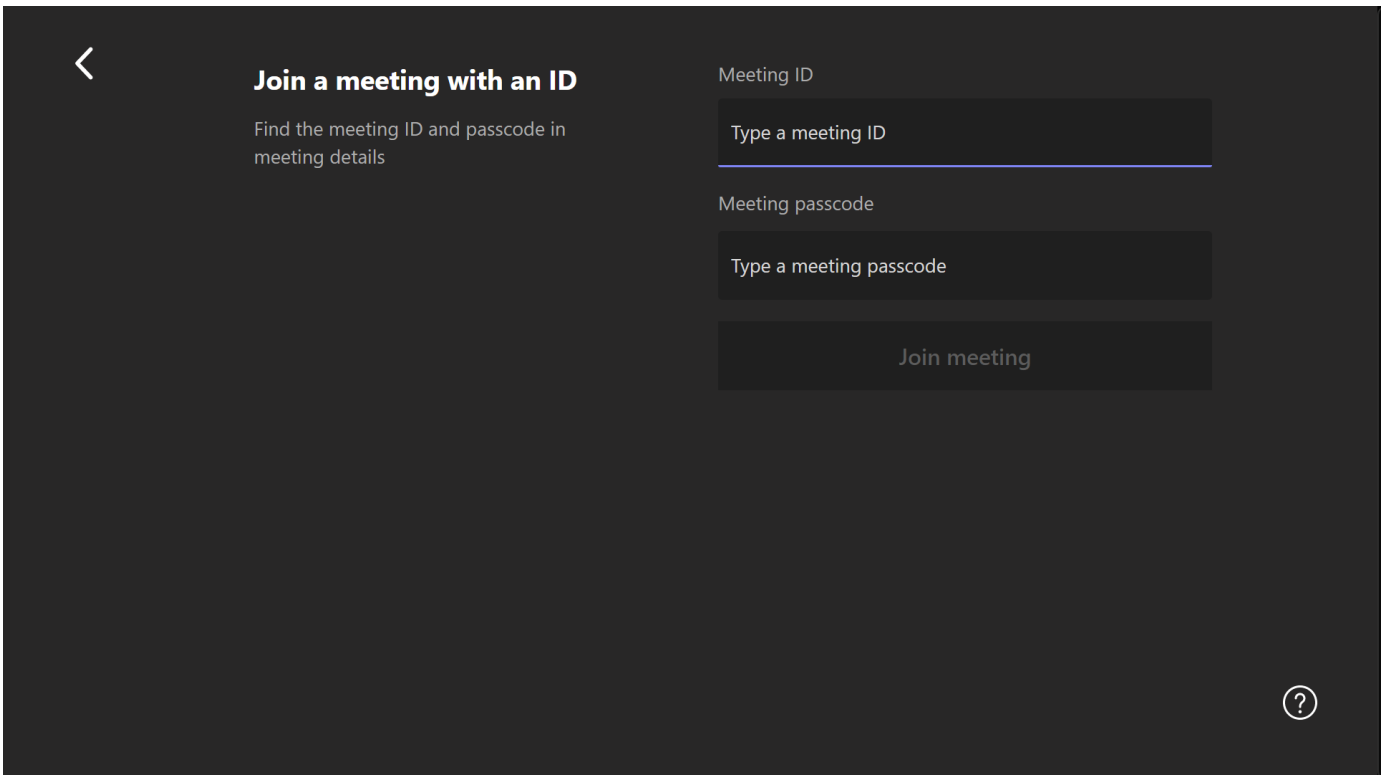
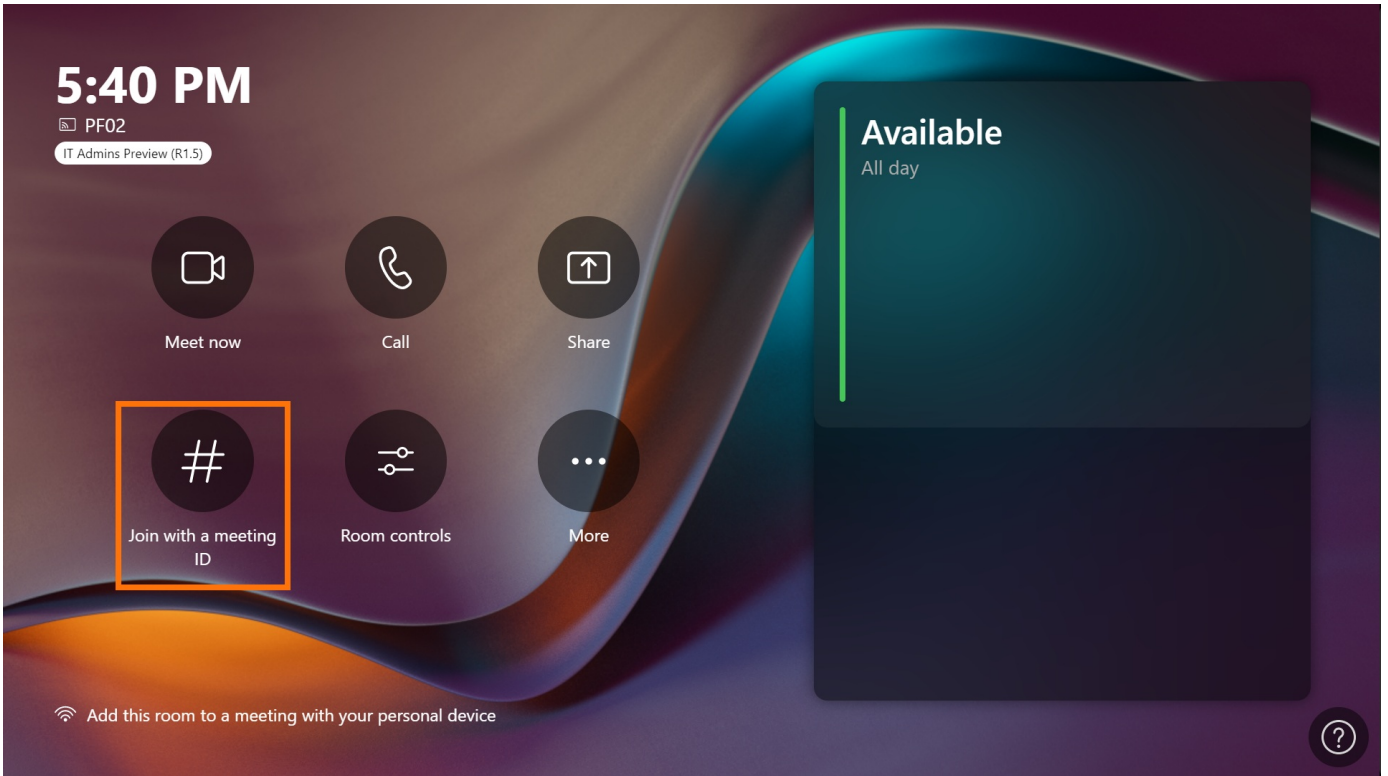

Join Third-party Meetings

MVC devices support joining Zoom/Cisco Webex meetings.

1. Go to **More > Settings** to enter the administrator password (default: sfb).
2. Select **Meetings** to set **Third-party meetings**.

3. Select **Save and exit**.

(Please refer to [Enable Teams Rooms devices to join third-party meetings](#) for more information).

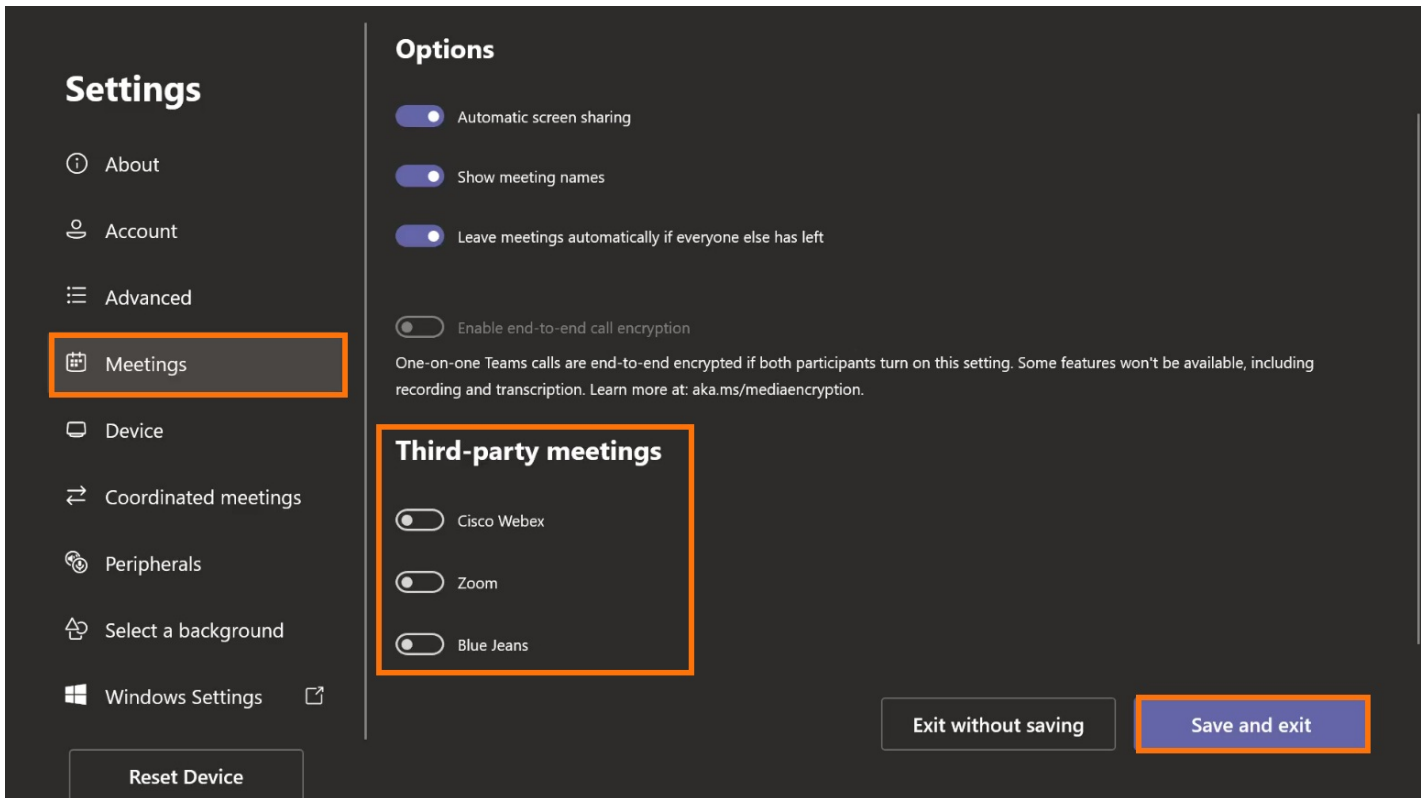

4. After inviting the account logged in by the MVC device to the Zoom/Webex client, the meeting information will be displayed in the meeting list on the home page, and you can directly select **Join** to enter the meeting.

NOTE

Screen sharing cannot be performed in a third-party meeting, but the other party can share the screen on the Zoom/Cisco Webex client. For more information, please refer to [Zoom Document](#) and [Cisco Webex Document](#).

FAQ

How to get the meeting ID and password in the meeting?

You can view the meeting ID and password in **Details**.

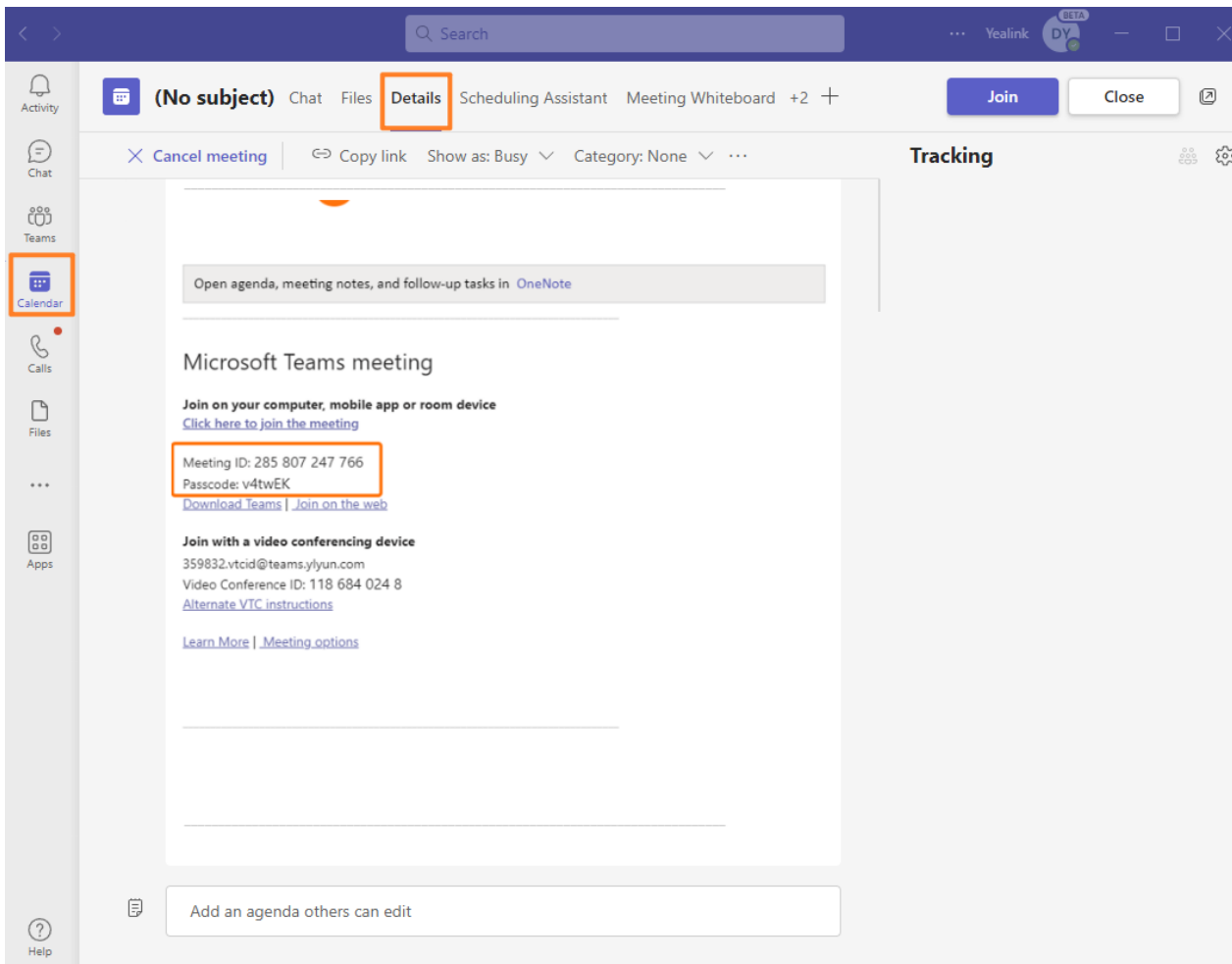

When joining a meeting, it keeps showing that you are connecting and can't enter it.

The network may need to be connected better. Please check whether the network is connected, and you can reset the network cable to try again.

Why can't the dual-screen display be used after the MVC device joins the Zoom meeting?

The way to join a third-party Zoom meeting is through the web user interface, so dual-displays cannot be used in third-party meetings.

Meeting Microphone

Introduction

You can adjust your microphone at any time during the meeting.

How to Use

Mute/Unmute Microphone

Select  to mute or unmute the microphone.

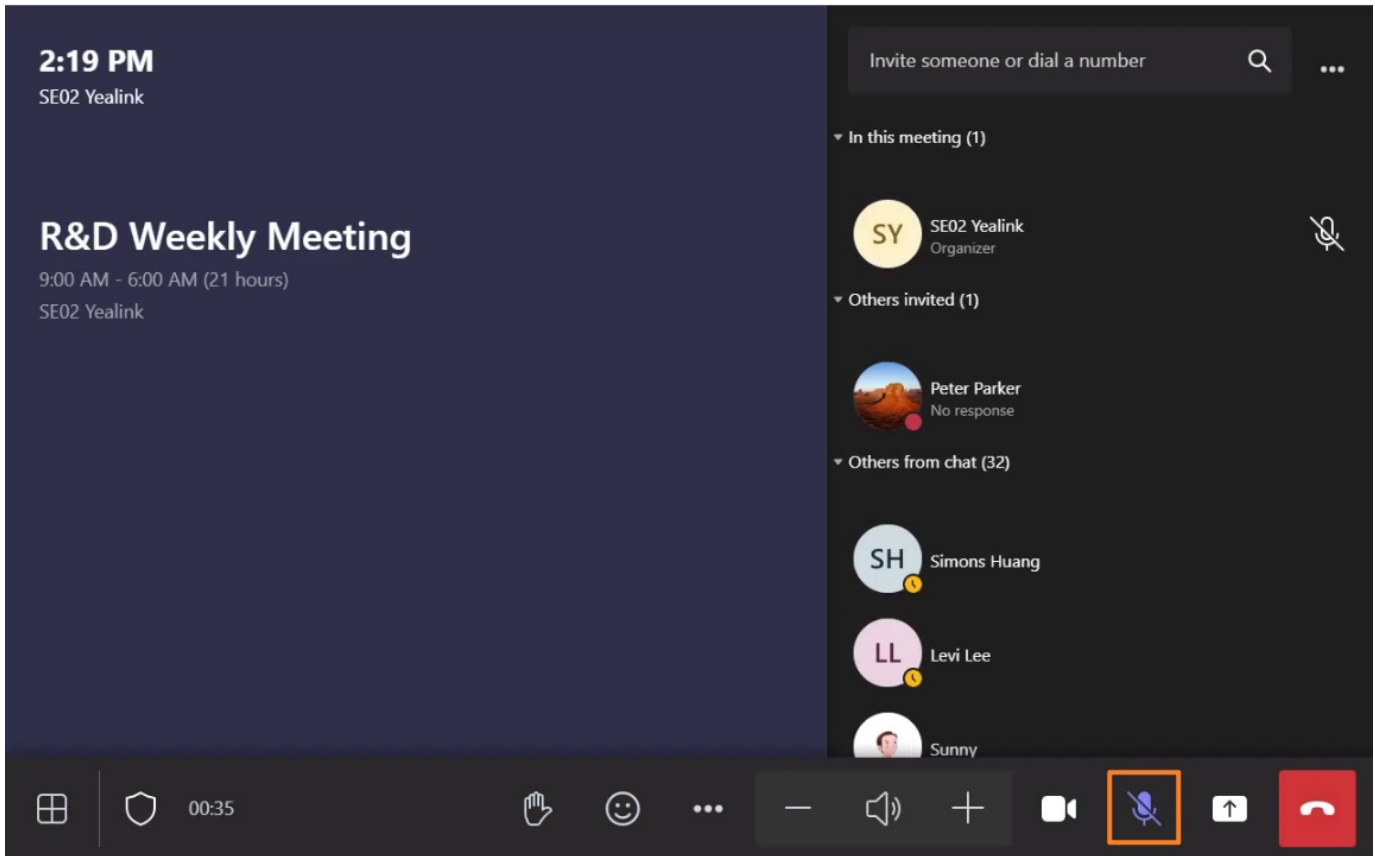

FAQ

The audio is abnormal, or the sound volume is too low in the meeting.

When there is noise in the surrounding circumstance, the meeting system will automatically suppress the noise to ensure the meeting quality. At this time, the participant's voice may be suppressed by the noise, resulting in too low volume caused by excessive suppression. You can appropriately reduce the degree of noise suppression.

Meeting Speaker

Introduction

You can adjust your speaker at any time during the meeting.

How to Use

Select  to adjust the speaker volume.

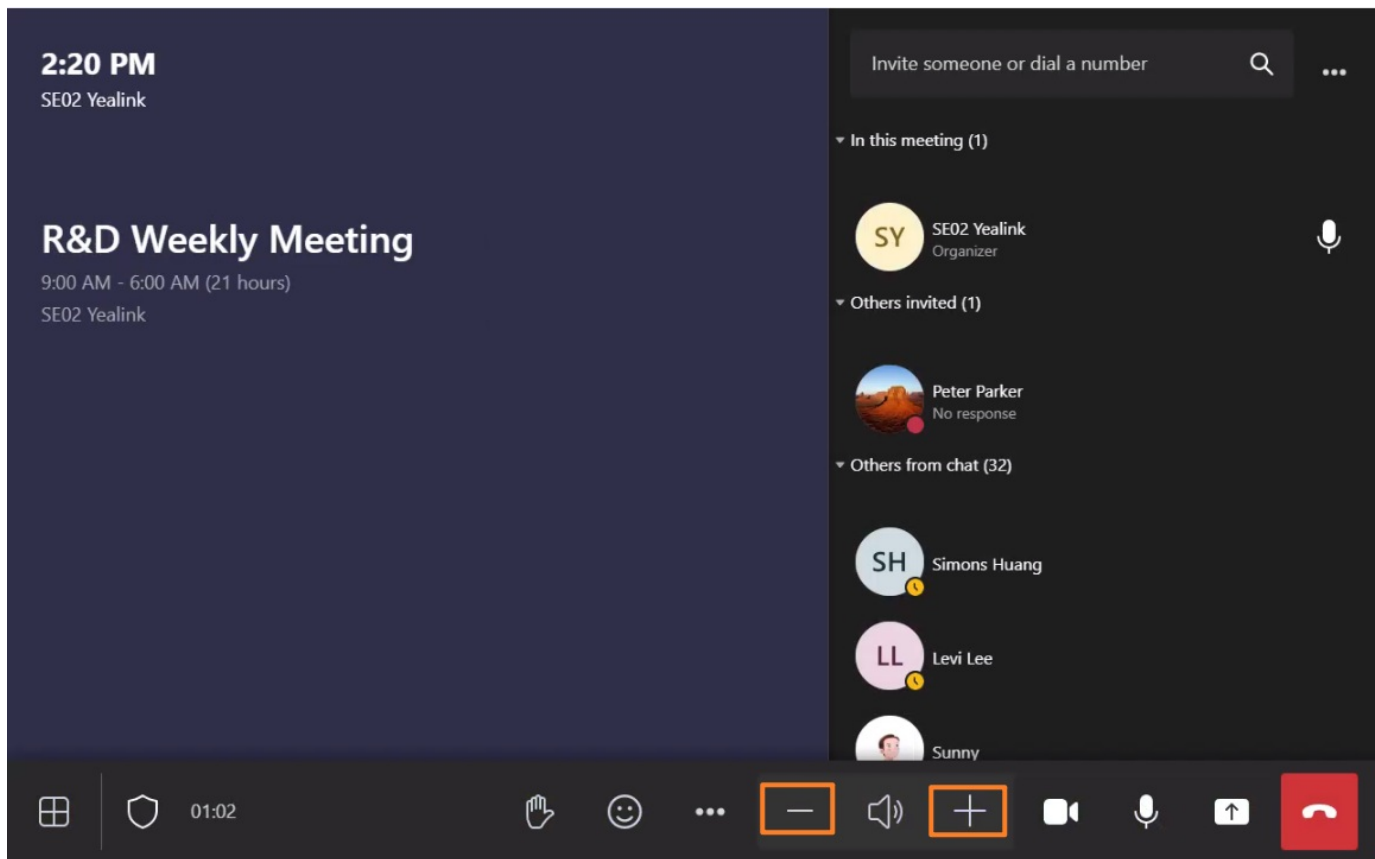

Local Meeting Camera

Introduction

You can adjust your camera at any time during the meeting.

How to Use

Select the Camera

Select the drop-down menu of  to choose which camera to use.

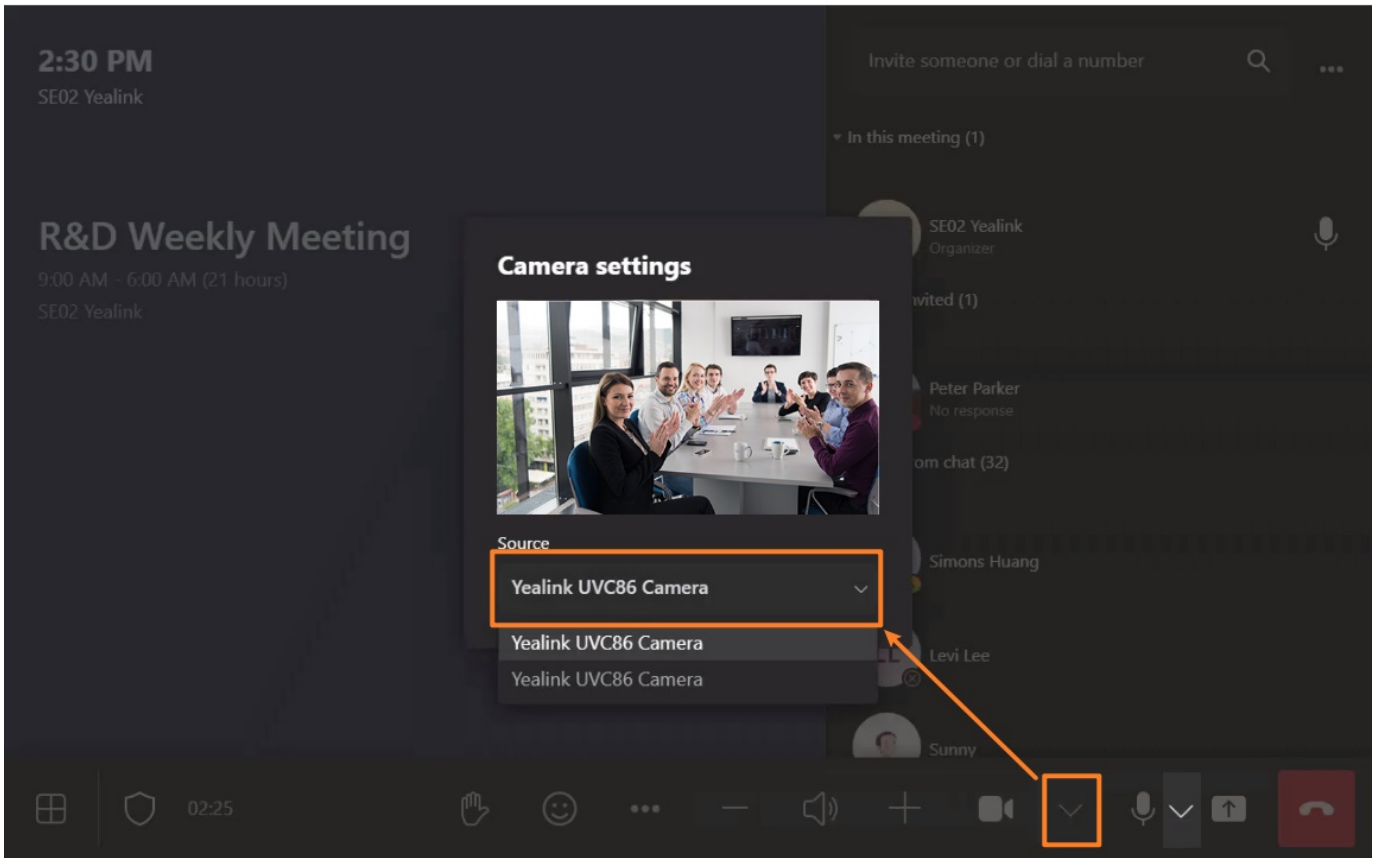

Enable/Disable the Camera

Select  to enable or disable it.

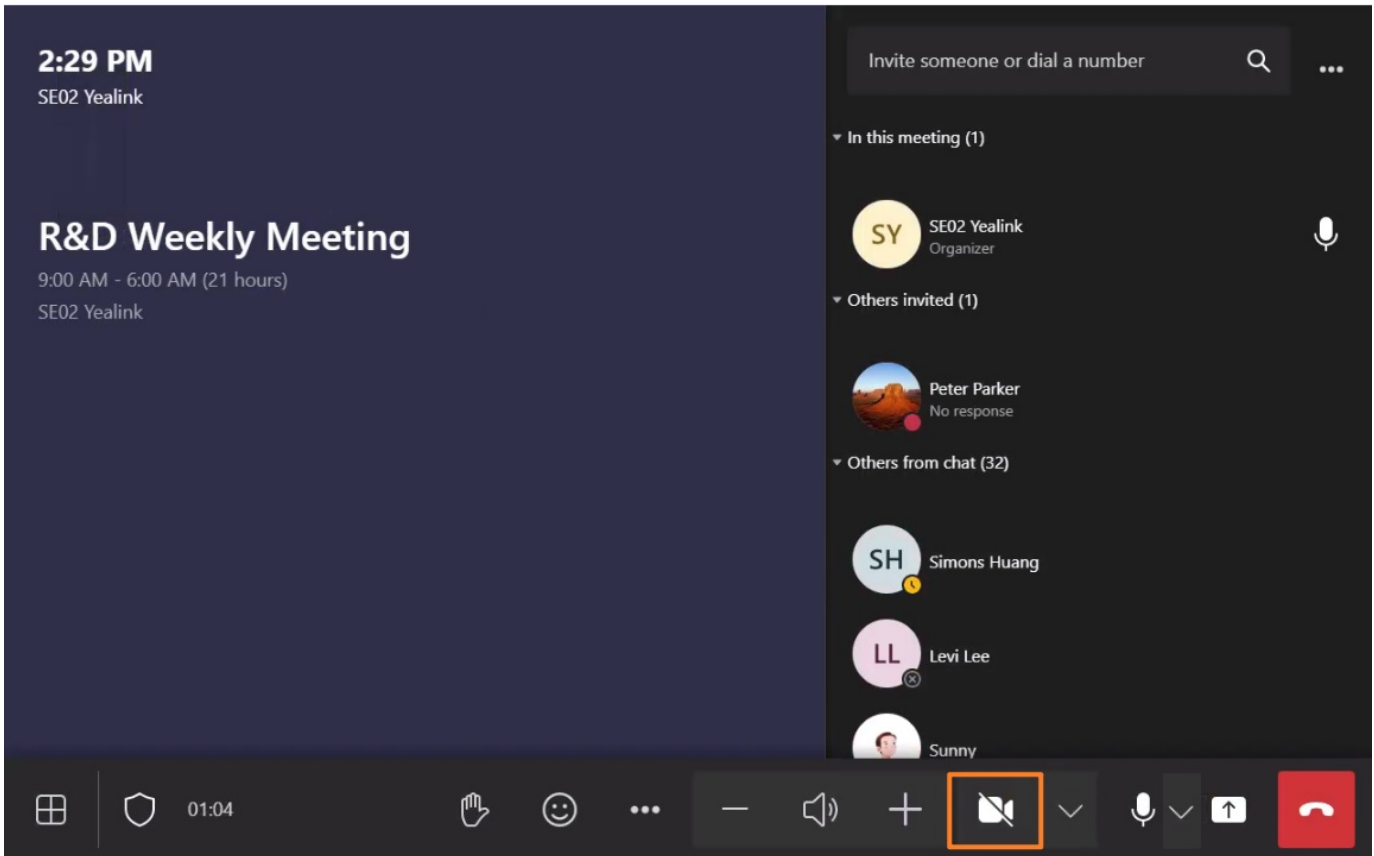

Manage Participants

Introduction

As a meeting host, you can pin, spotlight, mute, invite or remove participants.

The host can also spotlight up to 9 videos. Spotlight puts a participant as the primary active speaker for all participants. All participants will only see the selected speakers as the active speaker. This feature is often used to spotlight a keynote speaker.

How to Use

1. Manage the Audio and Video of Participants

1. Select **Participant** in the host controls to open the Participants panel.
2. Select **Mute participant/Pin for me/Spotlight for everyone** in the meeting.

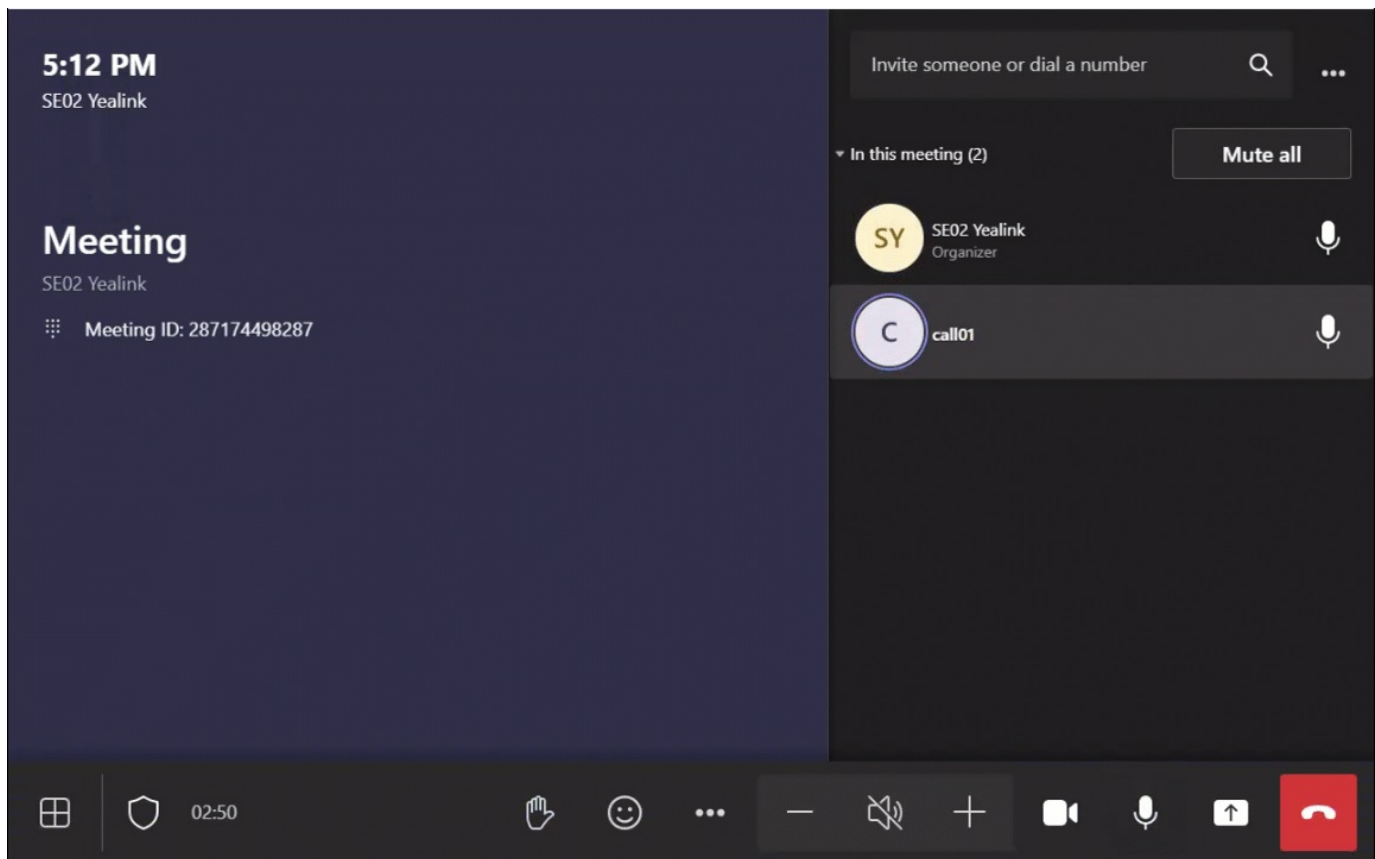

Effect Demonstration

Pin for me/Spotlight on everyone:

When you set Participant A to **pin for me**, participant A is displayed on a large screen in your video screen.

When you set Participant A to **spotlight for every**, participant A is displayed on a large screen in everyone's video screen.



Hide for me (set your video screen to hide):

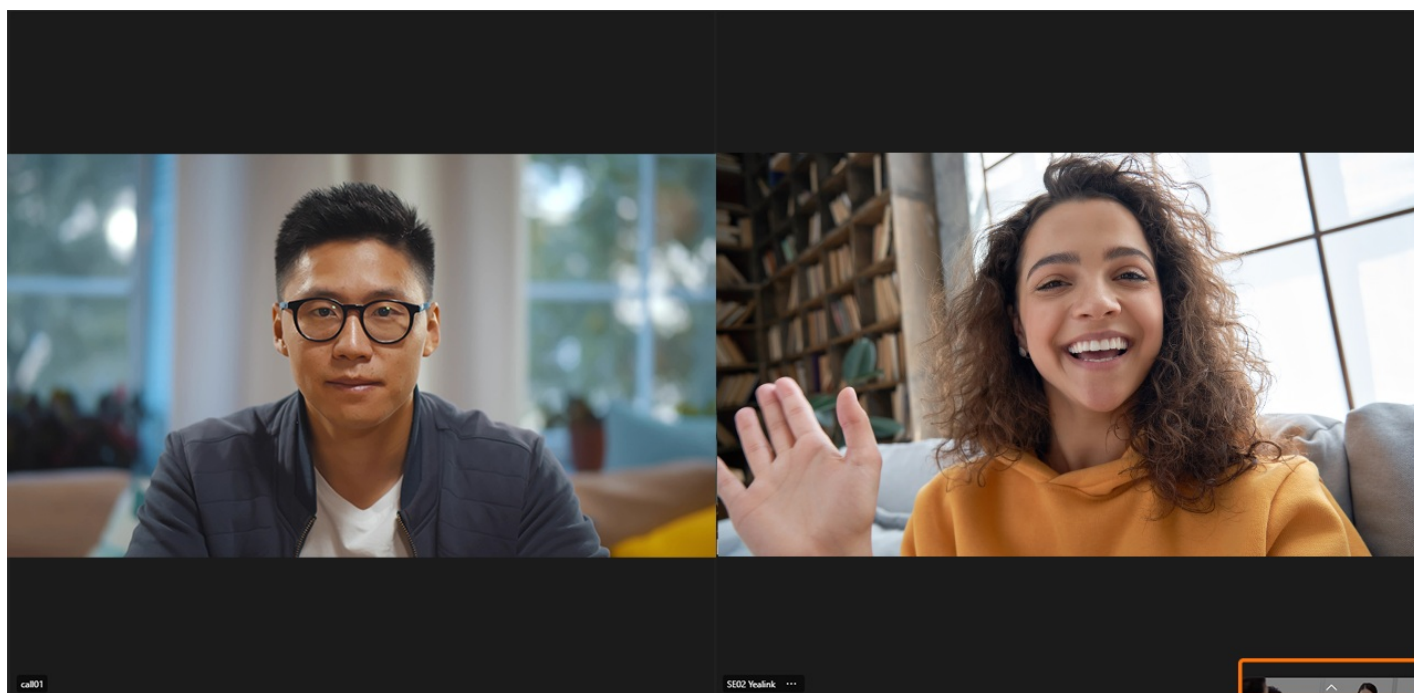

2. Set as Participant

Select a participant and select **Make an attendee** in the meeting. After setting them as participants, you can restrict them from using the microphone, camera, etc.

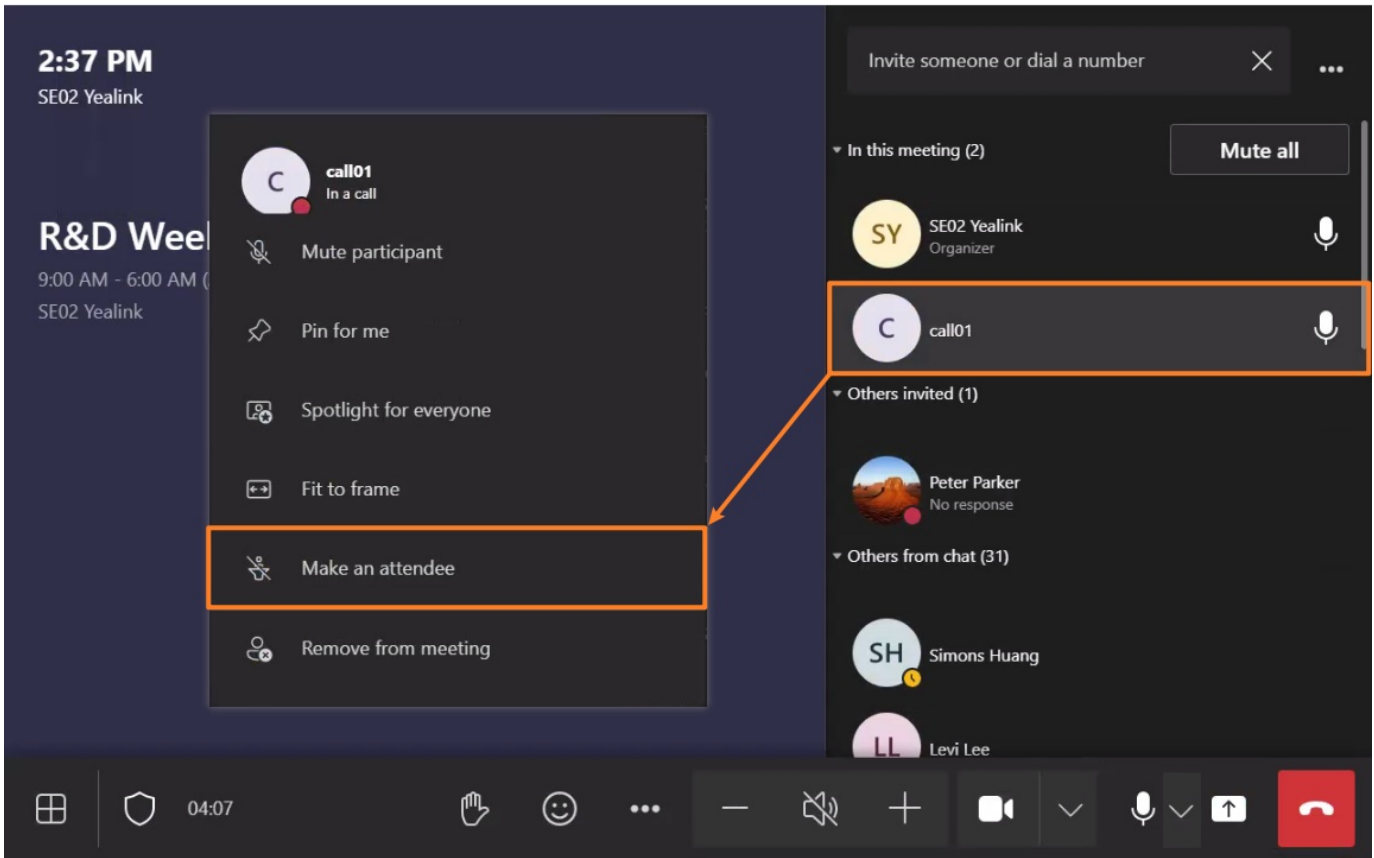

3. Invite Participant

1. Select **Invite someone or dial a number** in the meeting.
2. Select **Request to join**.

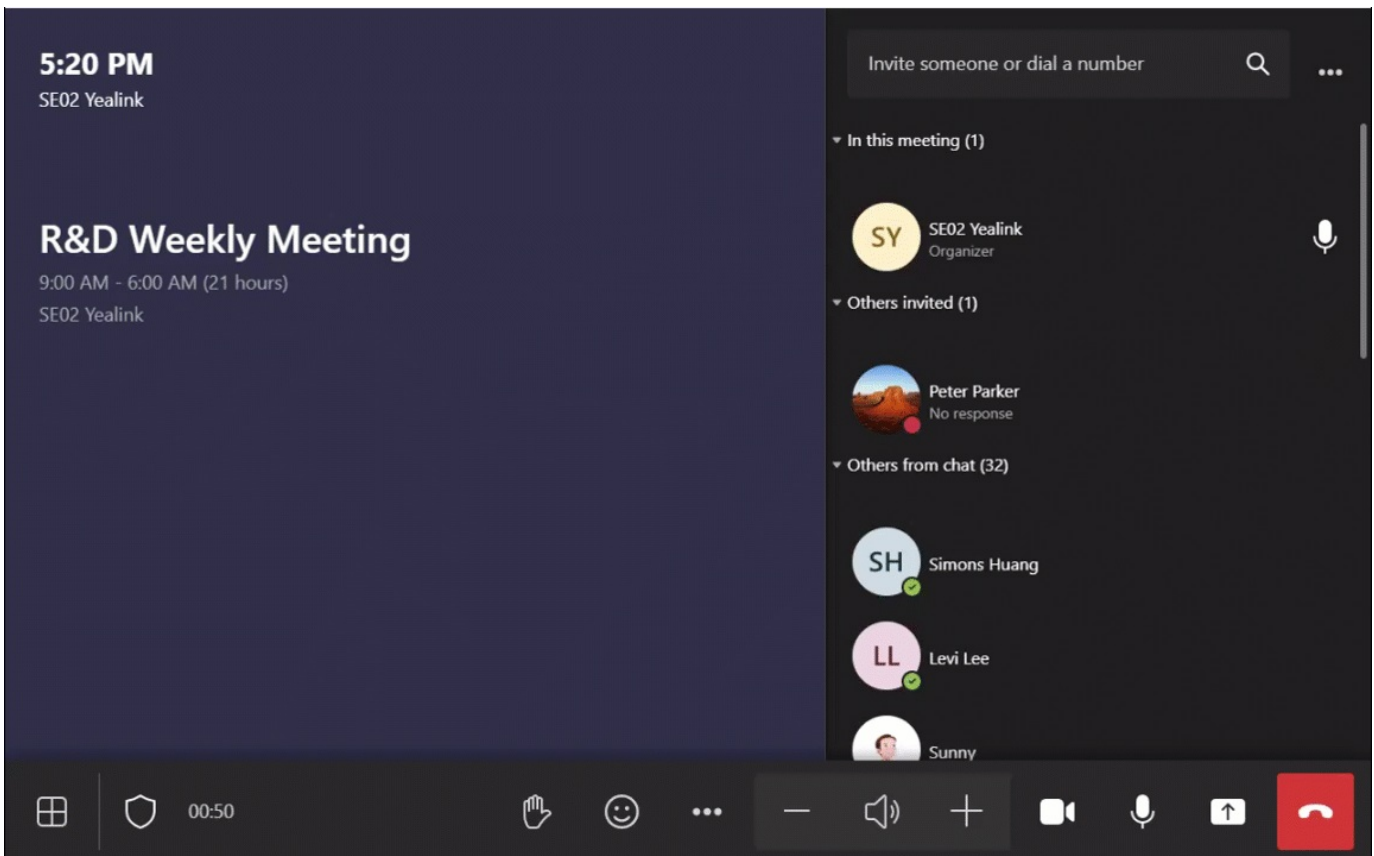

4. Remove Participant

Select **Remove from meeting** to remove the participant.

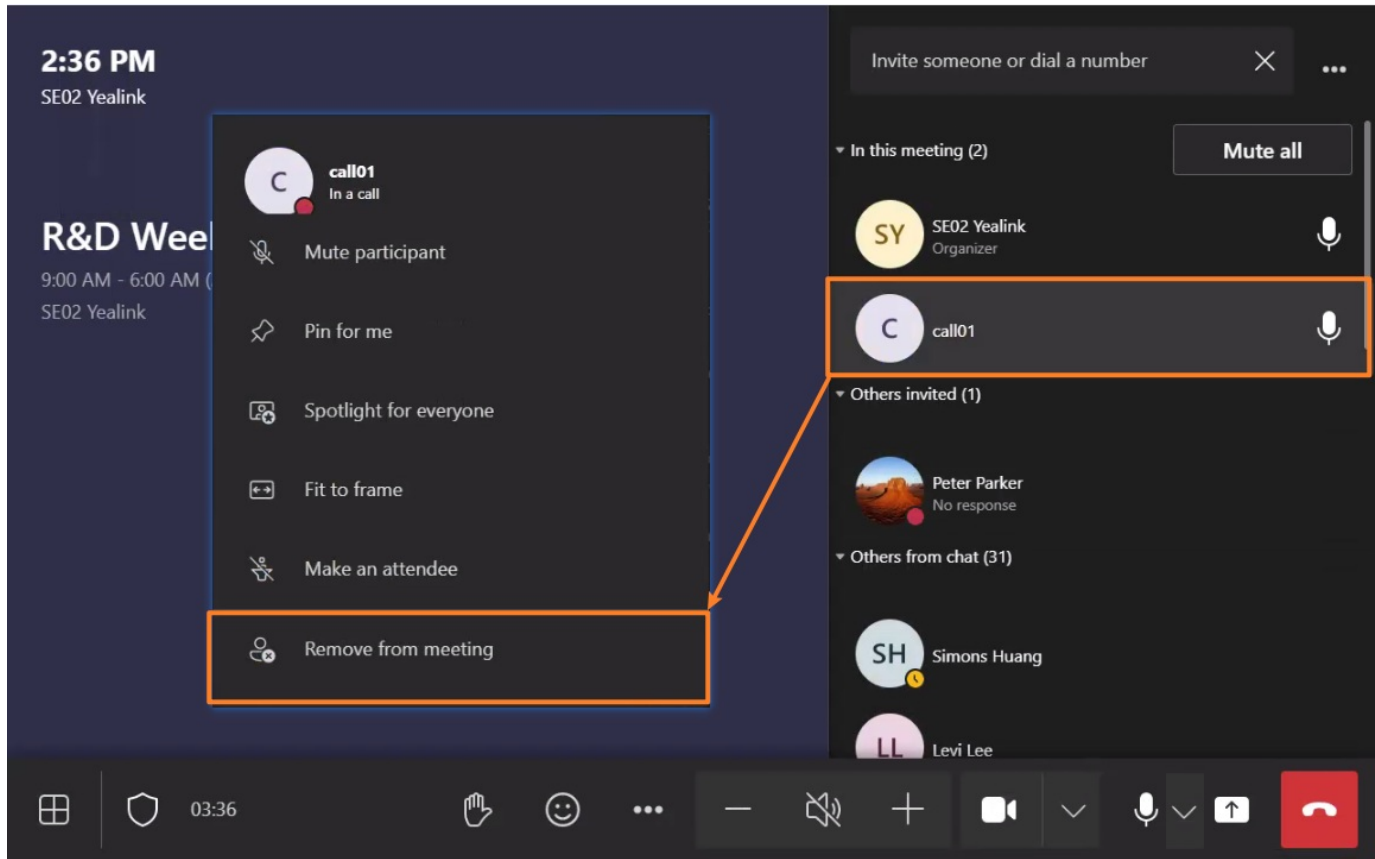

FAQ

Why the microphone/camera cannot be enabled during the meeting?

You cannot use the microphone/camera if you are set as a participant (the microphone/camera is disabled). You can ask the meeting organizer to enable the microphone/camera.

Meeting Layout

Introduction

During the meeting, you can set the meeting layout to **Gallery Mode**, **Together Mode**, etc.

How to Use

Gallery Mode

Go to  in the lower-left corner to select **Gallery**.

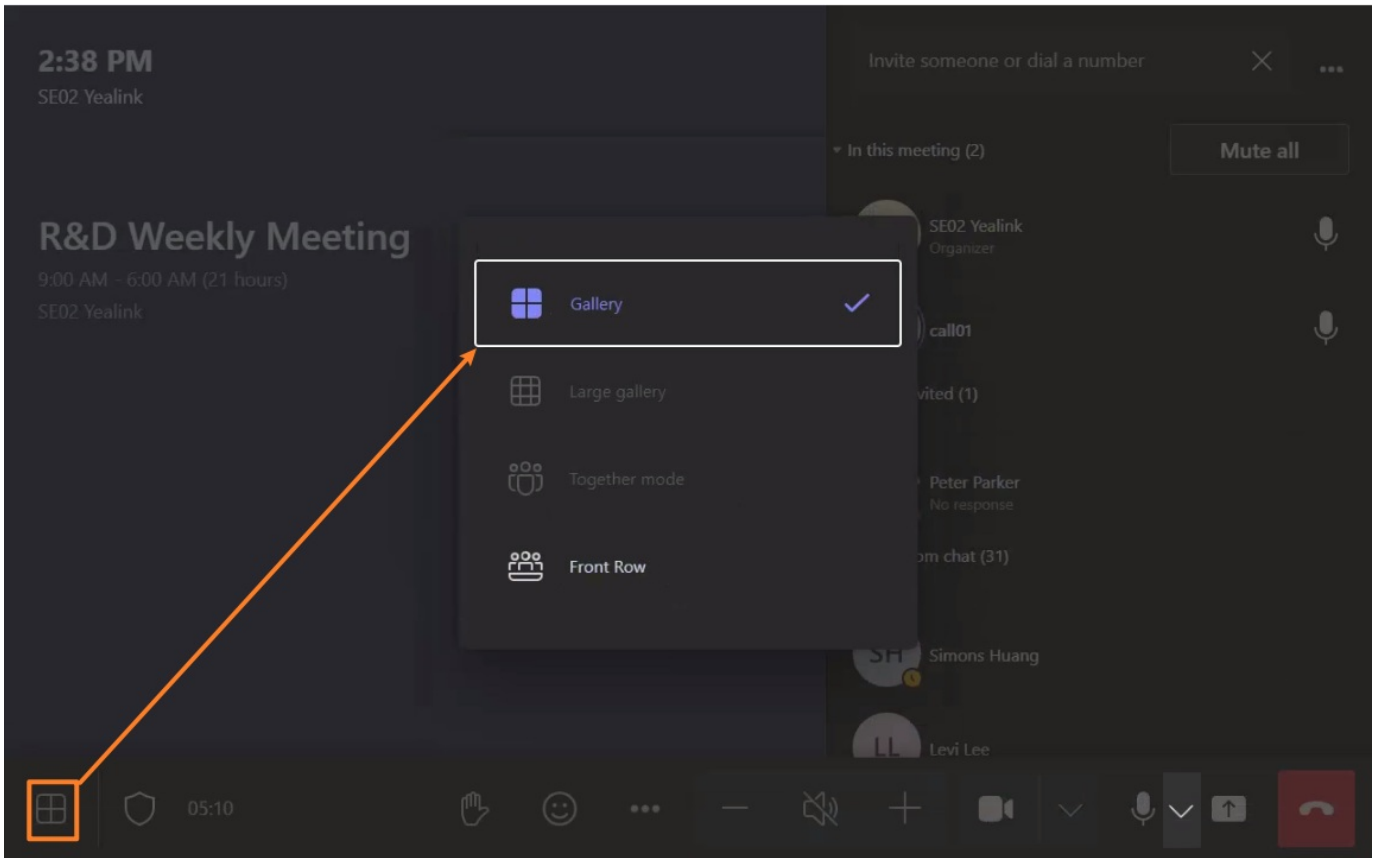

Effect Demonstration



Large Gallery Mode

At least 10 people in the meeting enable the camera before setting the **Large Gallery Mode**.

Go to  in the lower-left corner to select **Large Gallery**. It displays a 7x7 video layout where you can see up to 49 people simultaneously.

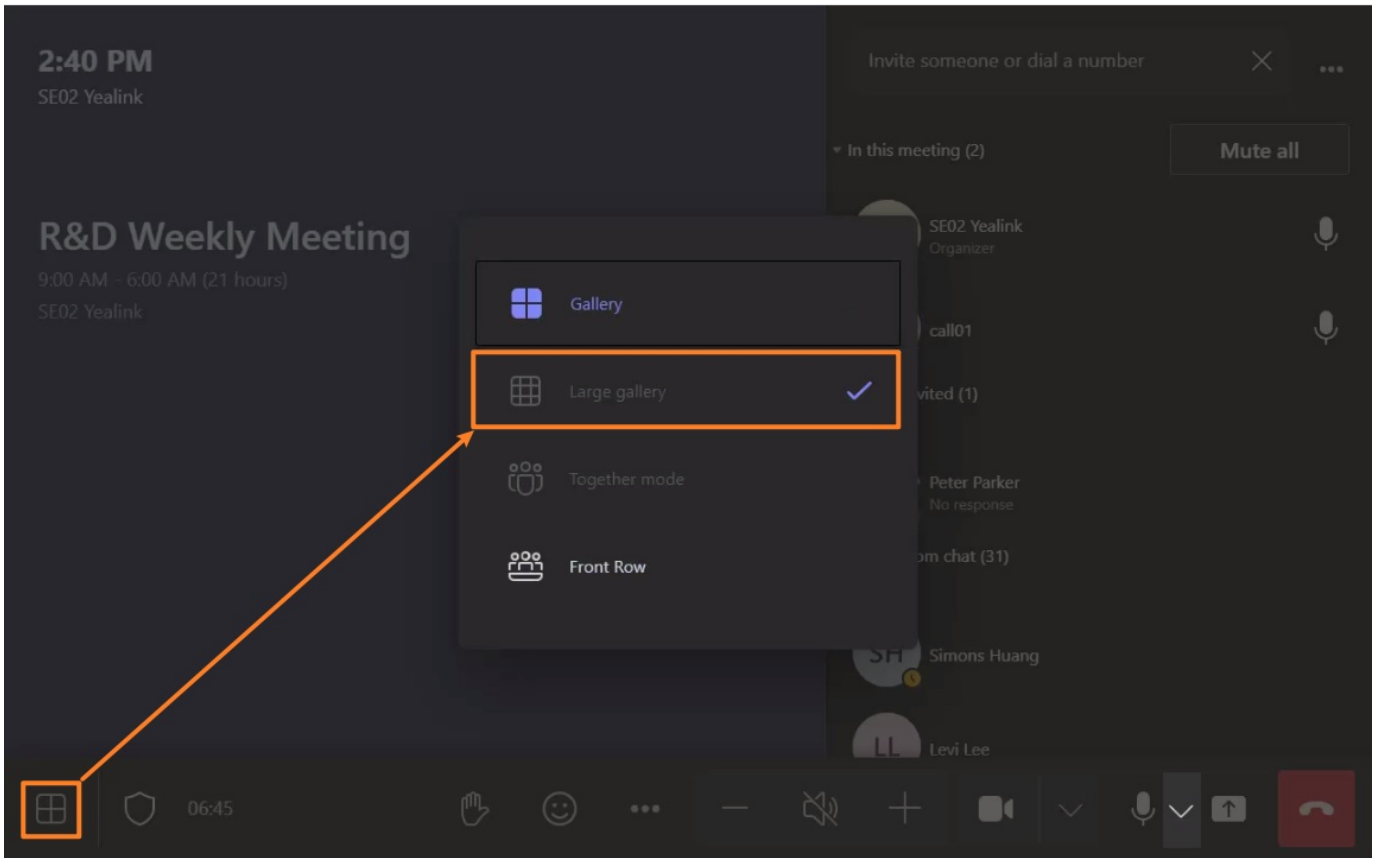

Effect Demonstration



Together Mode

At least 5 people enable the camera in the meeting.

Go to  in the lower-left corner to select **Together Mode**. It displays that you are in the same background as everyone in the meeting.

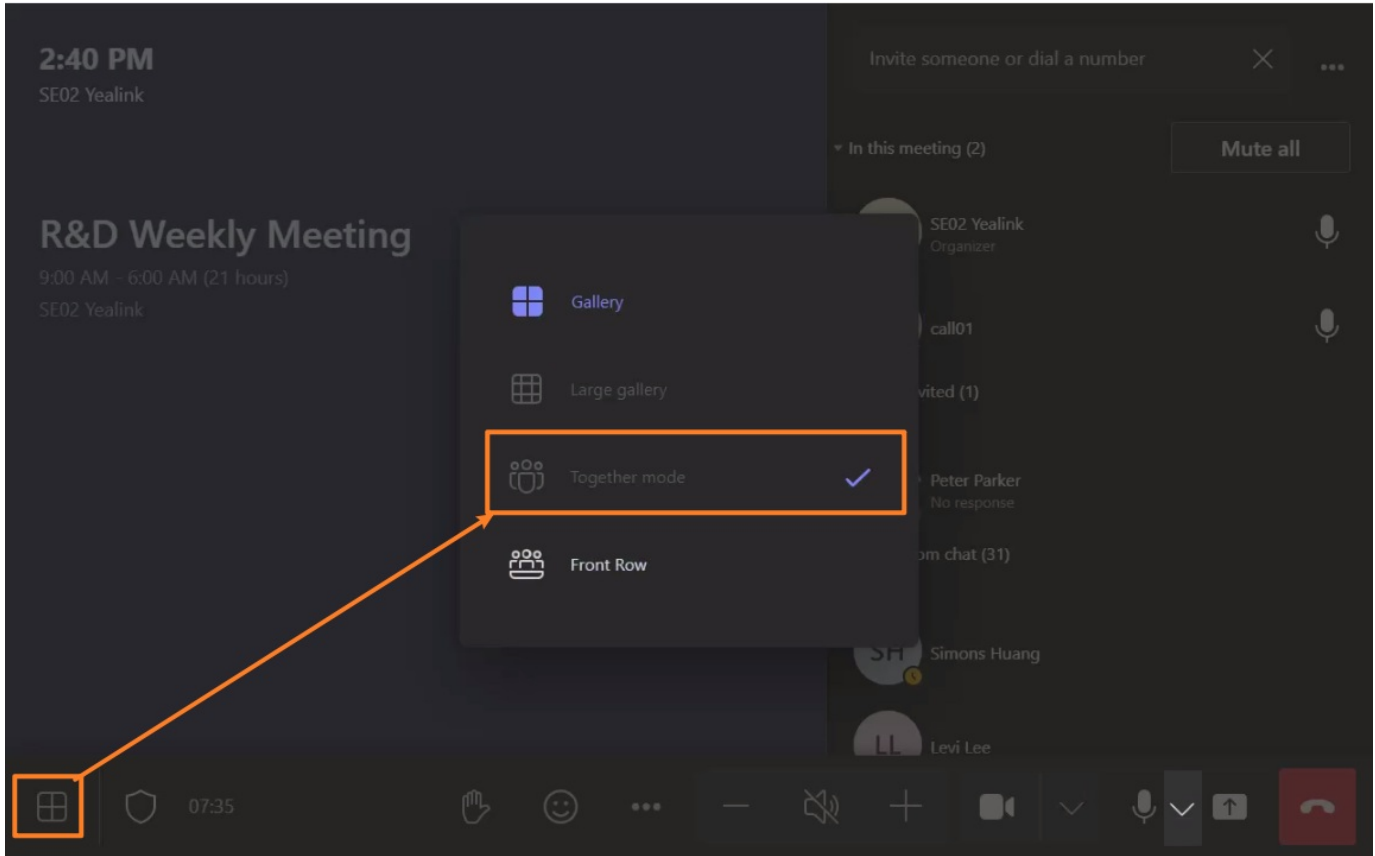

Effect Demonstration



Front Row Mode (preview)

Go to  in the lower-left corner to select **Front Row**. Participants appear in a row at the bottom of the display.

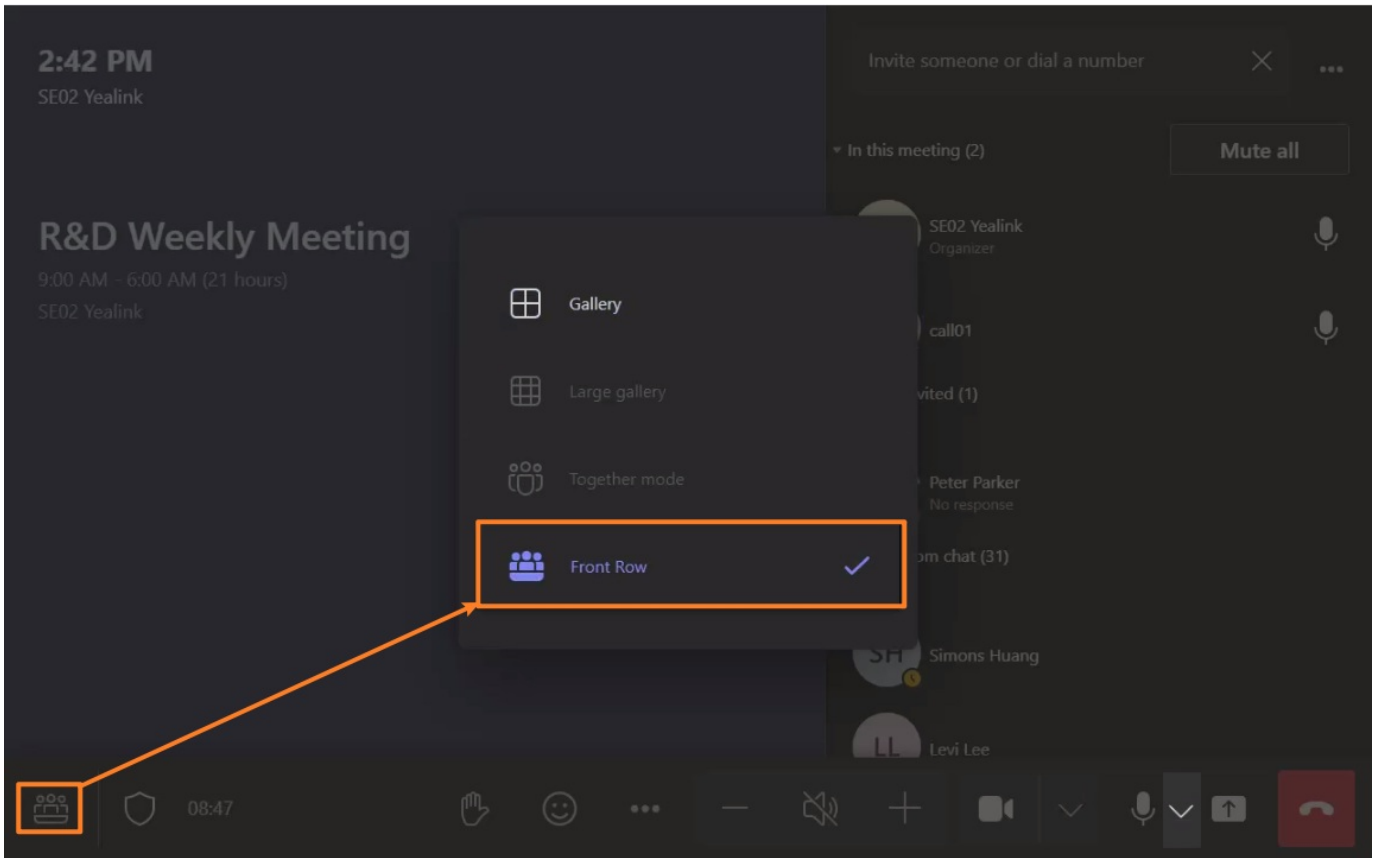

Effect Demonstration

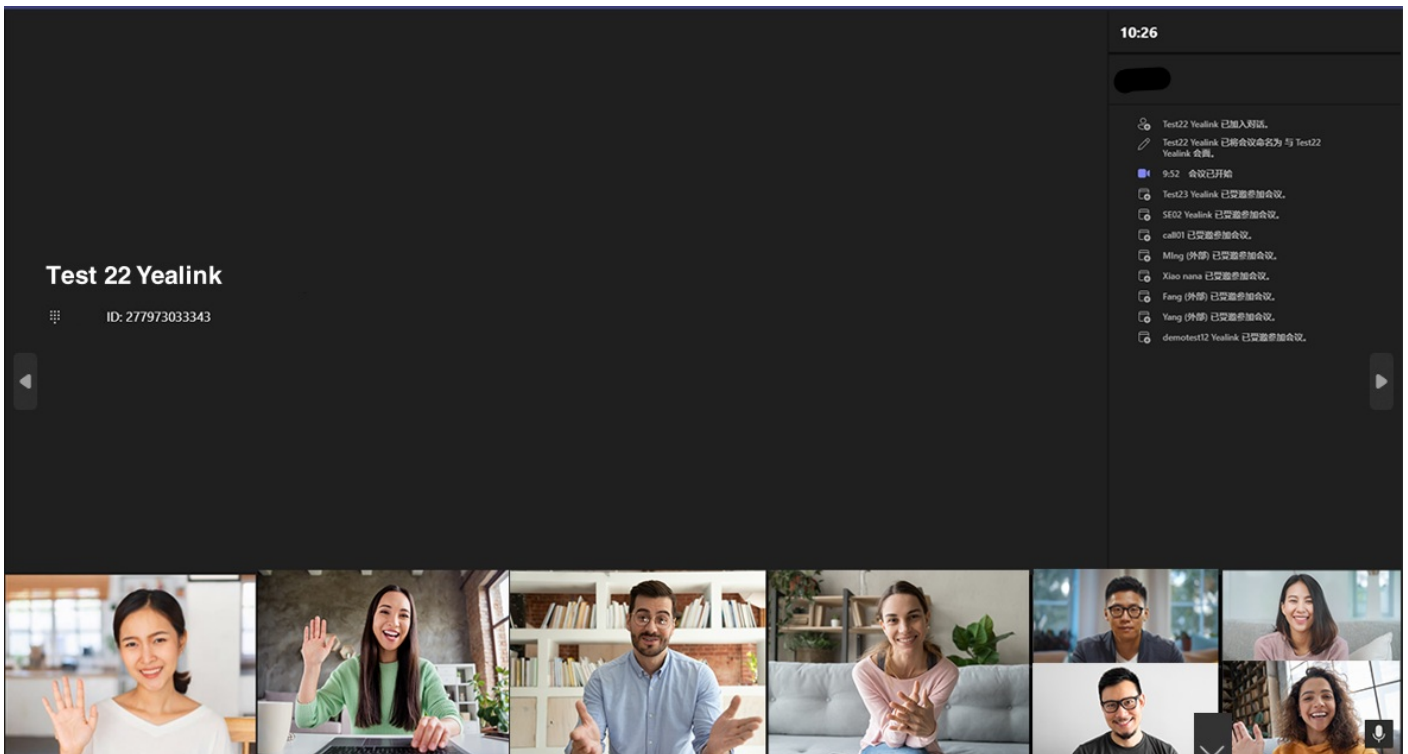

FAQ

There are no options for Large Gallery and Front Row Mode in the meeting.



- At least 10 people in the meeting enable the camera before the Together Mode option appears.
- At least 5 people in the meeting enable the camera before the Front Row Mode option appears.

Raise Your Hand

Introduction

You can raise your hand to speak in the meeting.

How to Use

1. Go to **Reaction**  on the toolbar along the bottom or top of the screen to select **Raise Hand**  in the meeting.
2. The host will be notified that you' ve raised your hand.
3. Select **Raise Hand**  to lower it if needed.

For the host, you can select the corresponding participant and select **Lower Hand** to cancel.

Effect Demonstration

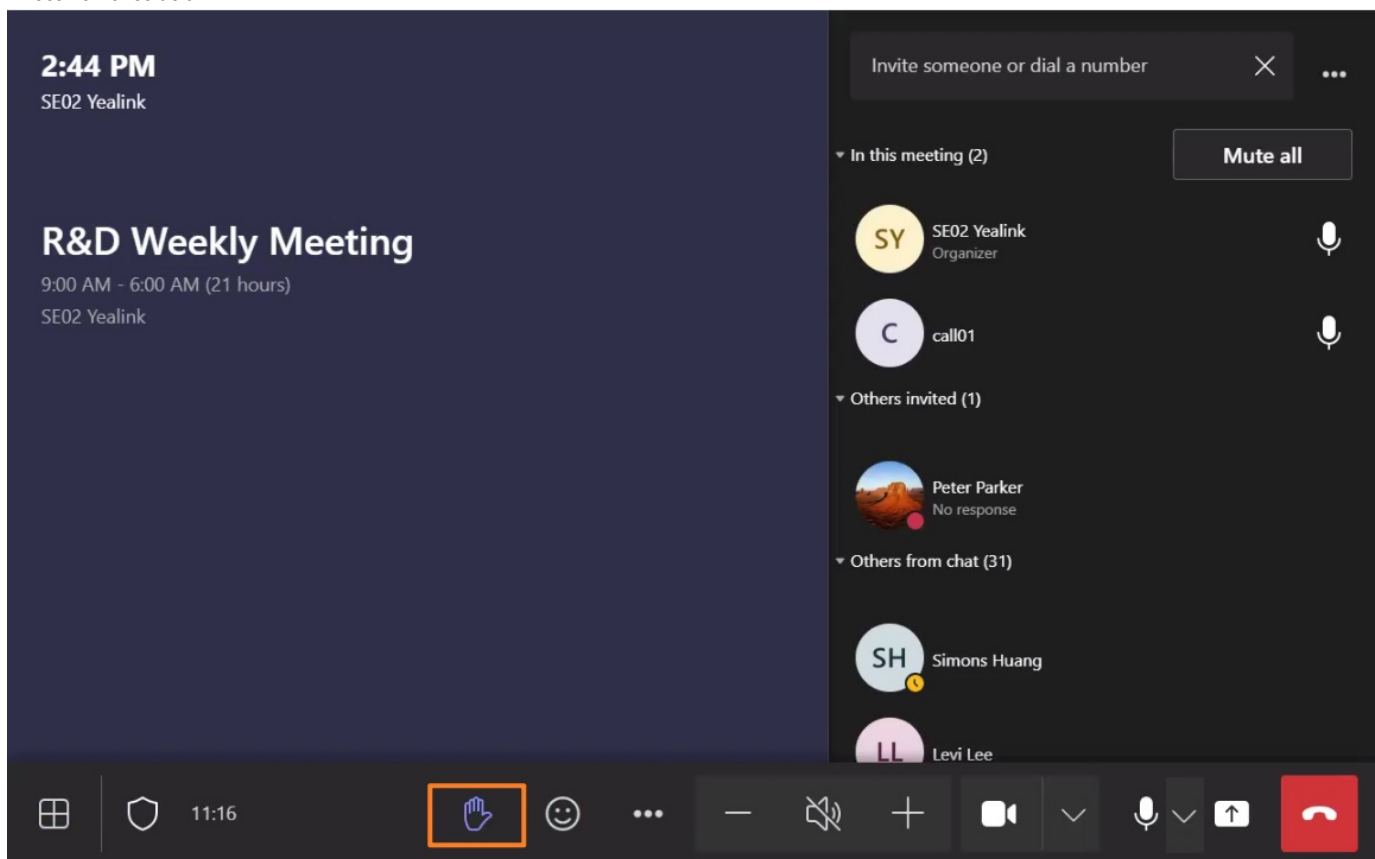

Send Reactions

Introduction

You can also send reactions during a meeting with images or icons similar to emojis. You can send **“clapping”** or **“thumbs up”** reactions when you like something or when your microphone is muted.

How to Use

Select the  during the meeting to send the emoji.

Effect Demonstration

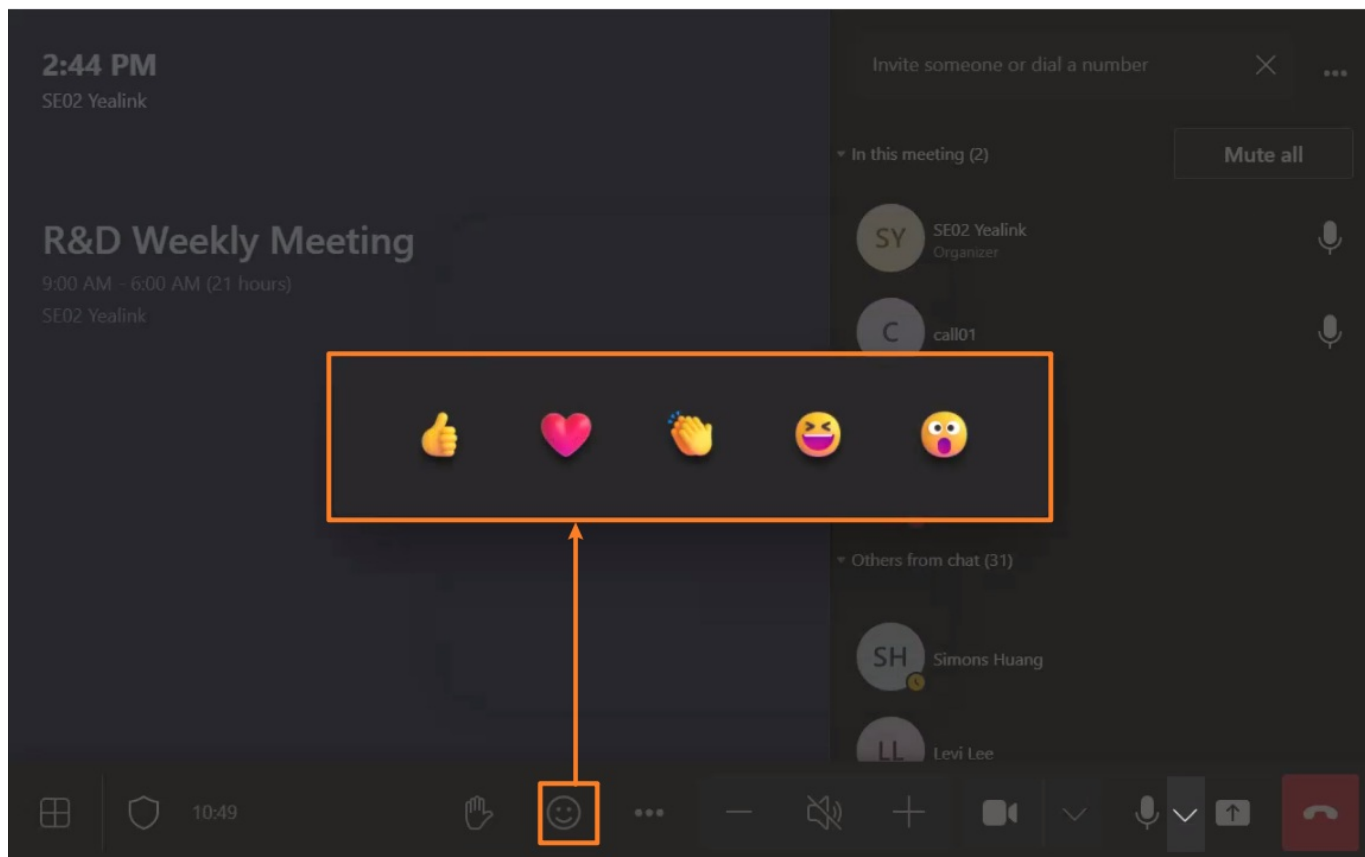

Meeting Control

Introduction

You can use more meeting control in the meeting.

How to Use

Select **More**  to select the other meeting control.

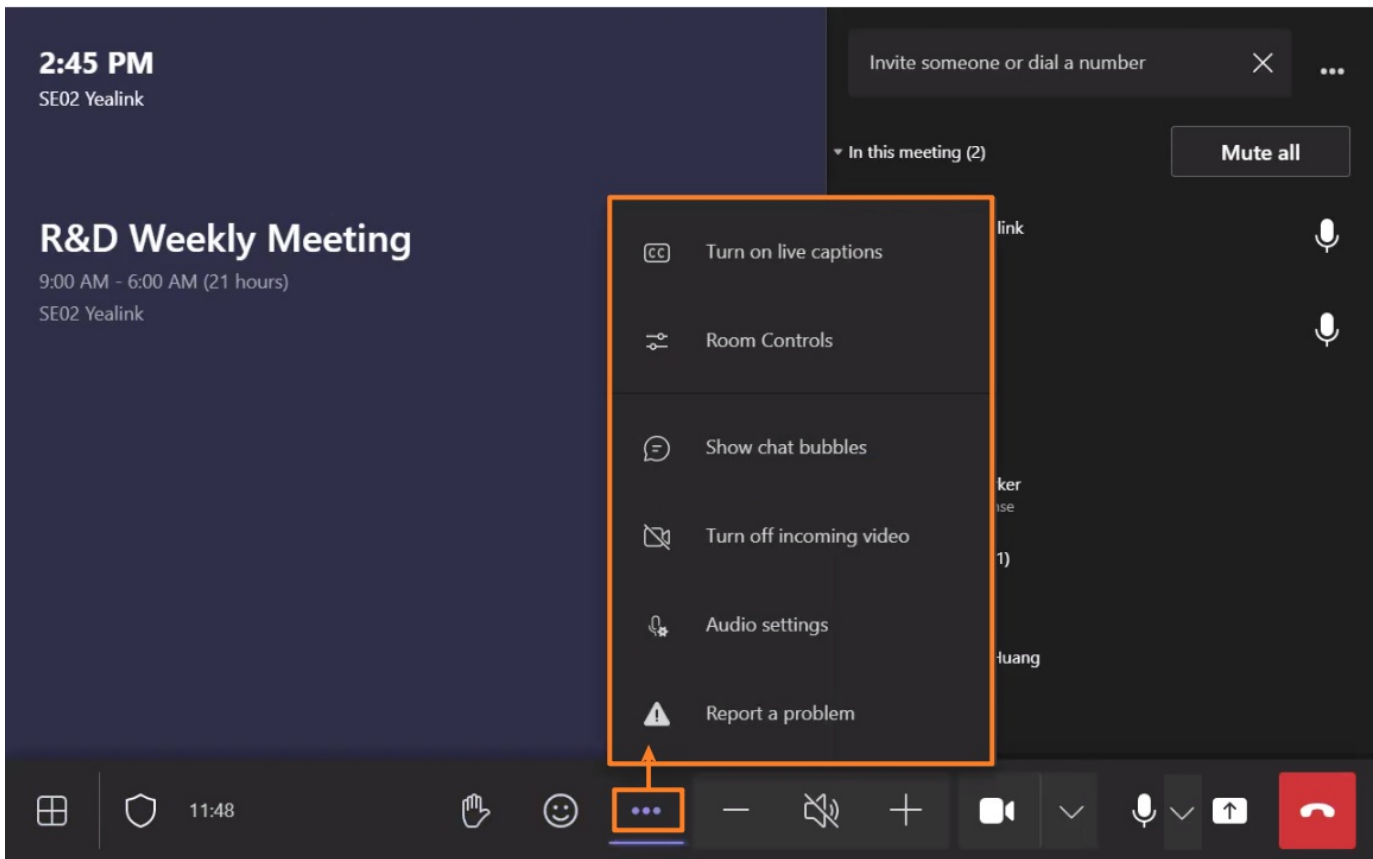

FAQ

How to fix the in-meeting prompt: “One or both of the monitors are disconnected” ?

Feedback

Introduction

If you have any problems in the meeting, you can give feedback.

How to Use

1. Go to **More**  **Report a problem**.
2. Select the problem type and describe it briefly.

We recommend you select **Include memory trace and heap snapshot**.

3. Select **Send feedback**.

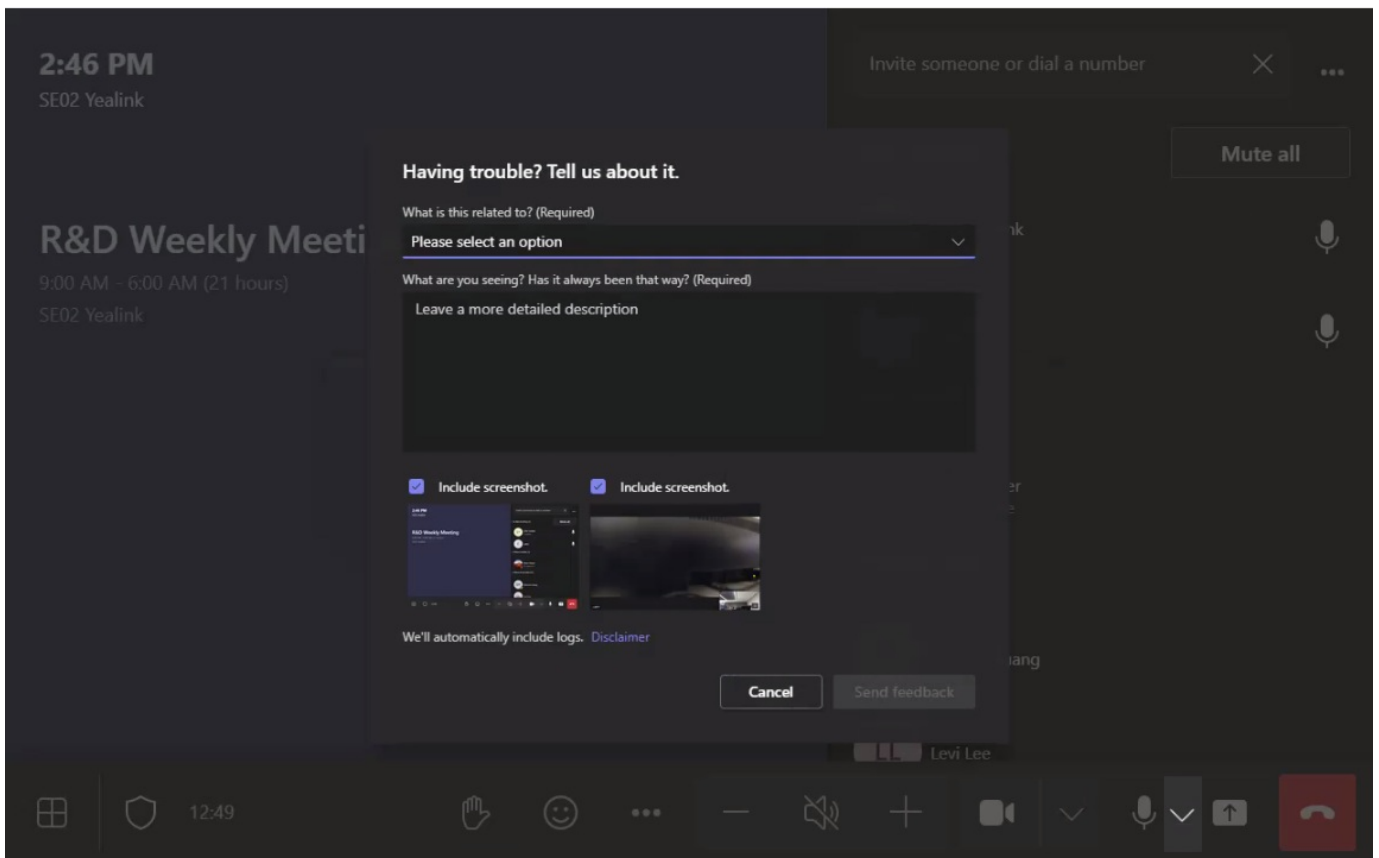
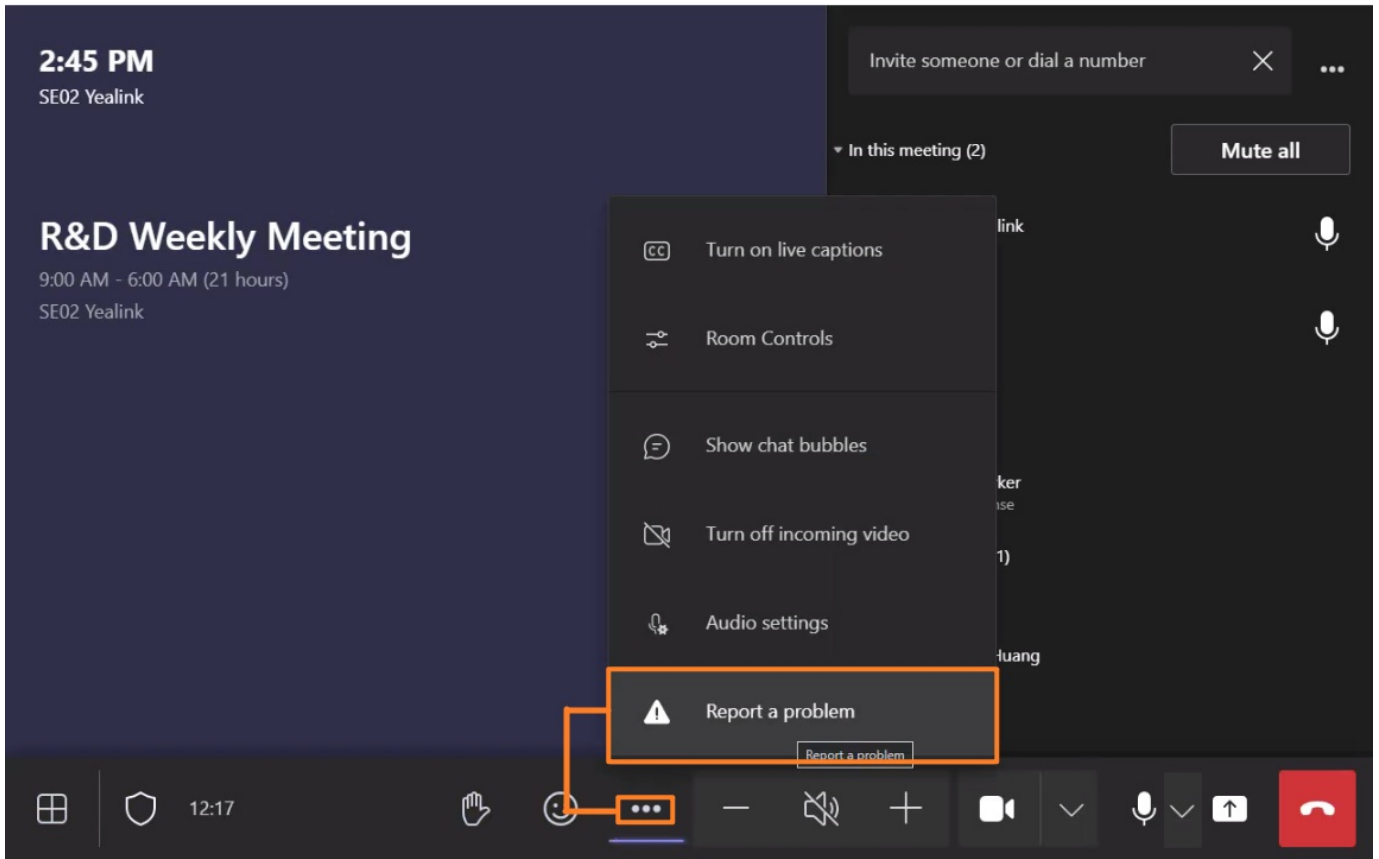

Content Sharing

Wired Content Sharing

Introduction

For MVC series products, you can achieve content sharing by connecting the Mini-PC to MShare.

For MVC II /III series products, you can achieve content sharing by connecting the USB-C to MTouch II/MTouch Plus.

How to Use

1. Connect Mini-PC to PC/Connect MTouch II /MTouch Plus to PC

- For the MVC series, you can connect the PC port of MShare to the USB port of your Mini-PC using a USB cable and connect the MShare to your PC using an HDMI cable and a Mini-DP cable.

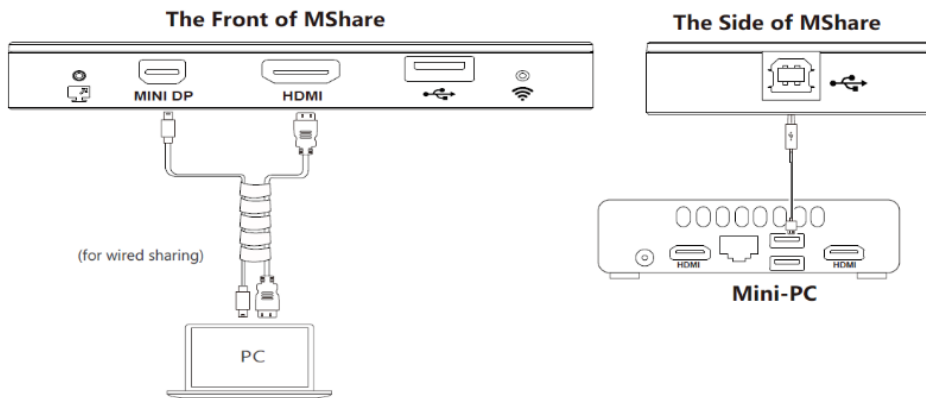

- For the MVC II/III series, you can connect the PC to MTouch II via USB-C (with HDMI adapter). You can use any of the interfaces, depending on the interfaces available on your PC.

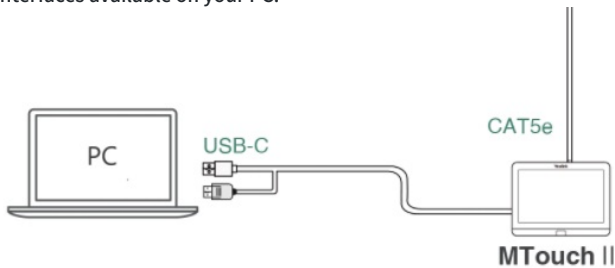

2. Start Sharing

When you are not in a meeting:

After connecting the USB-C cable or HDMI cable, select **Share/Stop Sharing**. If you set up the automatic screen sharing, the screen will automatically start sharing when you connect the USB-C cable or HDMI cable to the PC.

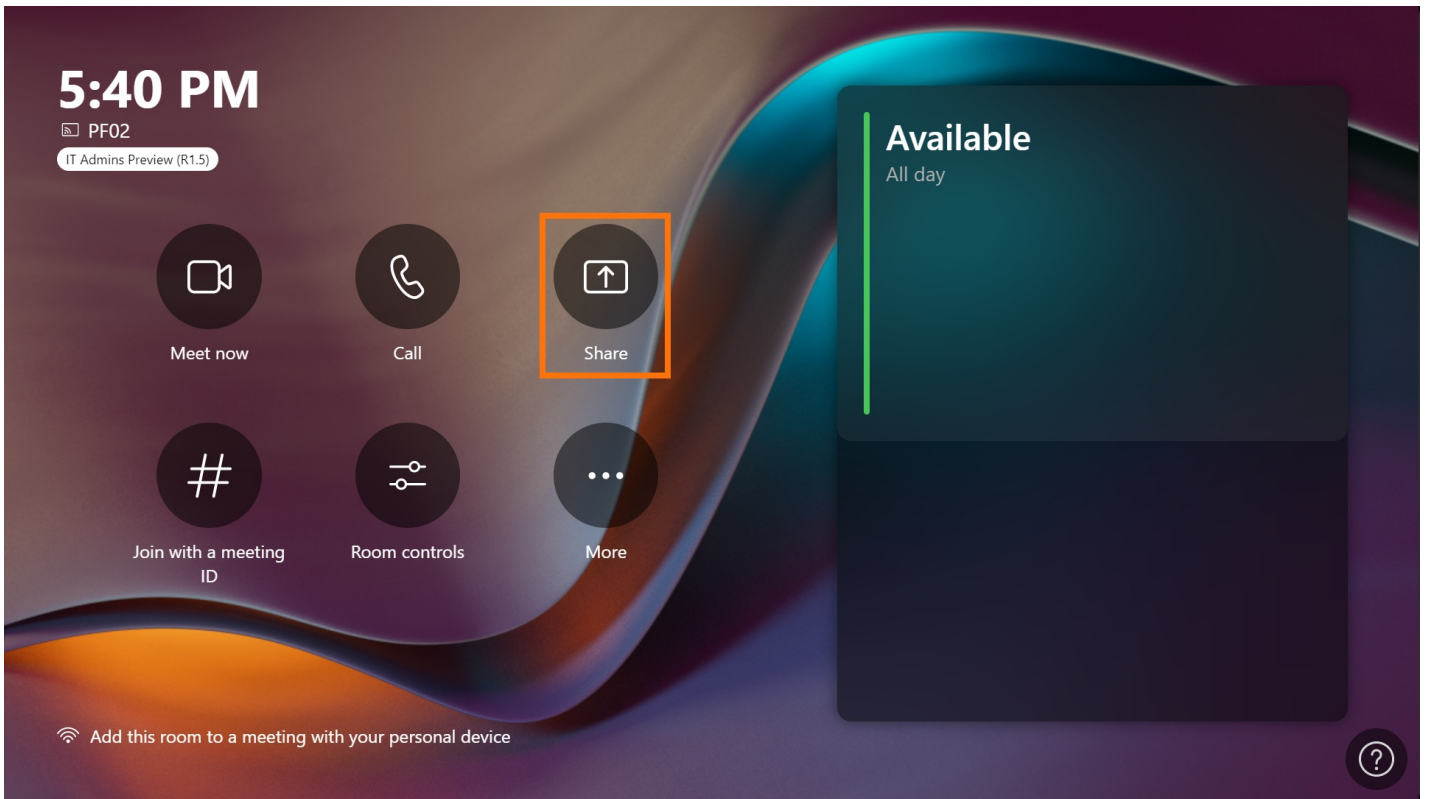

When you are in a meeting:

After connecting the HDMI cable, you can select  to share your screen.

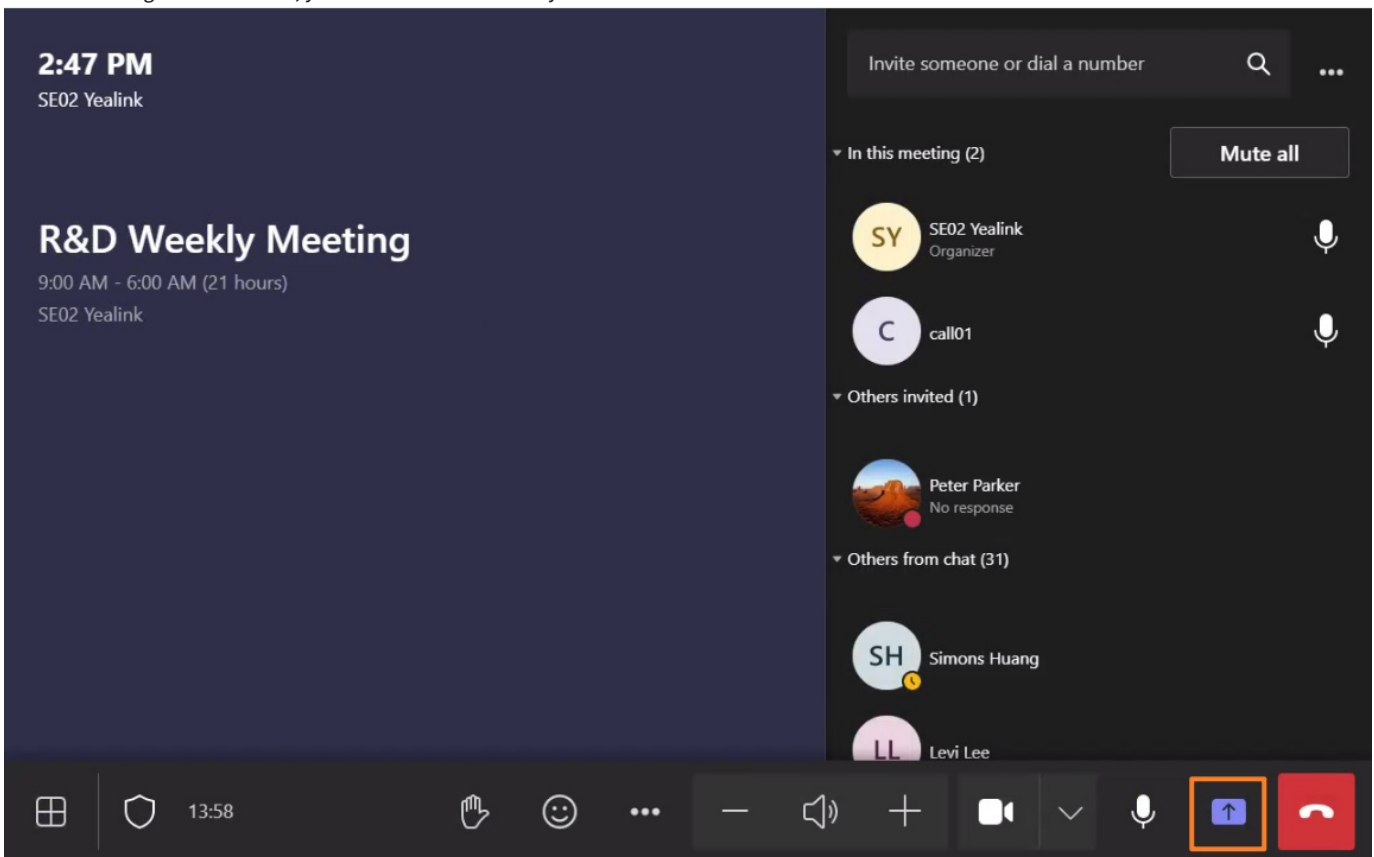

3. Share Audio

The wired sharing transmits all system audio output from your device. For example, if you have application audio notifications enabled during content sharing, participants hear these notification sounds together with the content audio. To avoid audio interference, the system automatically mutes your local audio when you start sharing content. When you stop sharing content, the system restores your local audio to its initial status.

4. Stop Sharing

Do one of the following:

- Click **Stop Sharing** in the status bar at the top of your computer screen.
- Tap **Stop Sharing** button on the MTouch II /MTouch Plus.
- Disconnect the USB-C cable.
- End the meeting.

FAQ

Is audio not being shared when sharing content?

Black screen while content sharing?

Troubleshooting the failure of wired content sharing?

After connecting the USB/HDMI to the PC, the MTouch II/MTouch Plus displays: No device connected?

Check whether MTouch II /MTouch Plus is updated to the latest version.

How to enable automatic content sharing?

1. Go to **More > Settings** (default password: sfb).
2. Select **Meetings** to enable **Automatic screen sharing**.
3. Select **Save and exit**.

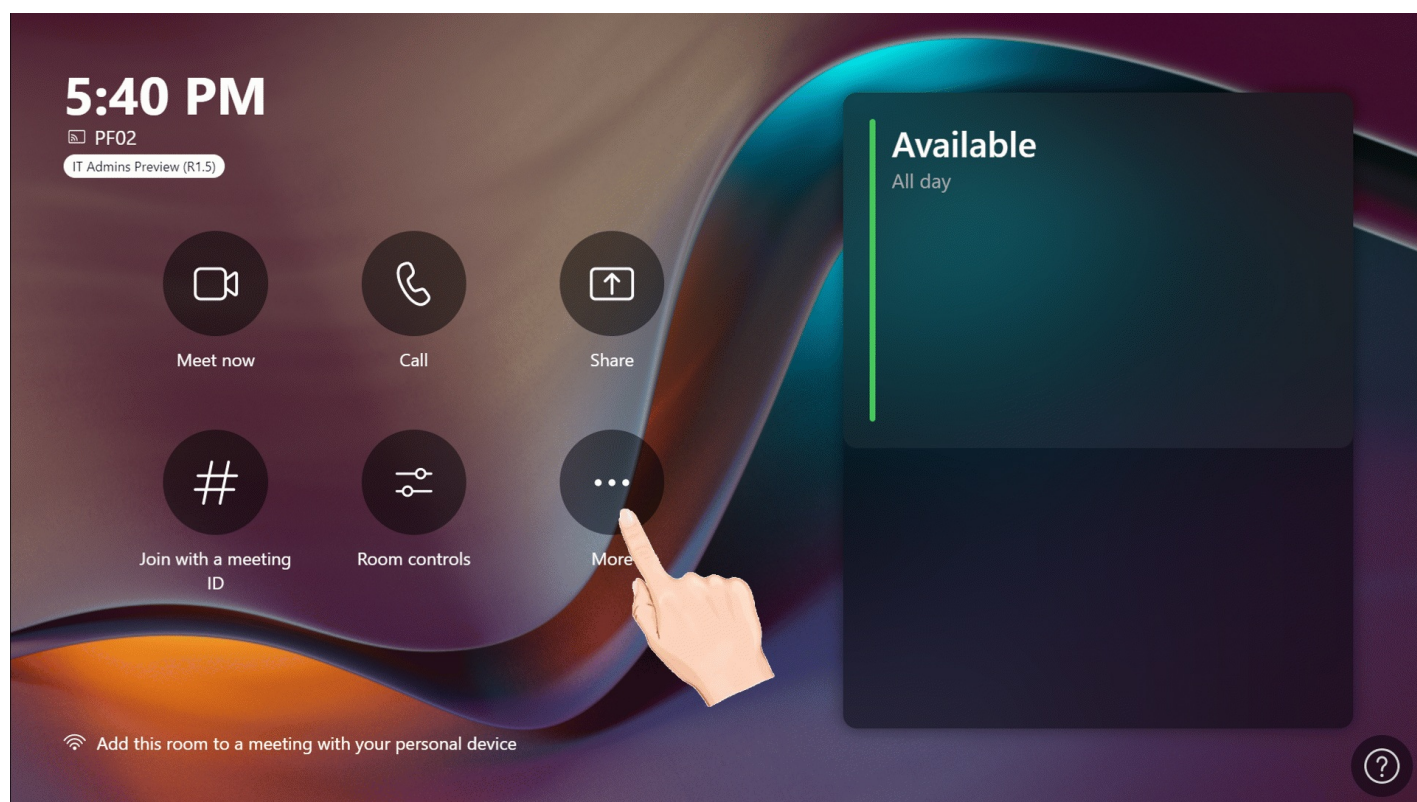

Wireless Content Sharing

Introduction

After pairing MTouch II with WPP20, you can use screen sharing. The MVC II series does not currently support screen sharing using WPP30. If you want to use WPP30 for screen sharing, you can choose RoomCast to work with WPP30, please refer to: [MVC and RoomCast wireless screen sharing](#).

WPP20 Compatibility

For the WPP20 compatible devices and the maximum number of compatible devices, please refer to [Teams Room Accessories Compatibility Lists](#).

LED Status

LED Indicator Color	Description
Flash green	Pairing/connecting, updating, or software not installed.
Breathing green	Connected to the PC, and waited to share the screen.
Solid green	Paired/sharing content.
Flash red	Connection failed/network disconnected.

How to Use

NOTE

- When using the Mac system, a prompt will automatically pop up to enable screen recording permission for Yealink Wireless Presentation Pod. If it does not pop up automatically, you can click the upper-left corner of the Mac screen and go to **System Preferences > Security and Privacy > Enable Screen Recording Automatically**. After enabling it, you can start using content sharing.
- The WPP20 supports content sharing on the PC running Windows 7, Windows 8, Windows 10, Windows 11 and Mac OS 10.10 or later.

1. Pair WPP20 with MTouch II

Connect WPP20 to the USB port of MTouch II for pairing, and wait for more than 3 seconds until the WPP20 LED indicator turns solid green.



2. Pair WPP20 with PC

Connect the WPP20 to the PC's USB port, and the PC will automatically pop up the Yealink Wireless Presentation Pod application.

NOTE

- When using the Mac system, a prompt will automatically pop up to enable screen recording permission for Yealink Wireless Presentation Pod. If it does not pop up automatically, you can tap in the upper-left corner of the Mac screen and go to **System Preferences > Security and Privacy > Enable Screen Recording Automatically**. After enabling it, you can start sharing content.
- If the firmware of the WPP20 is different from the endpoint, the PC will prompt you to update the firmware.
- For the WPP20: If your PC only has a USB-C port, you can connect the standard USB-C adapter to WPP20. The USB-C port of the WPP20 connected to the PC does not support plug-and-share.

3. Start Sharing

Method 1: Share via a button on WPP20

Press the presentation button of WPP20 to share your desktop.



Method 2: Share via the WPP20 software

1. Choose how to share your content:

- **Duplicate screen:** The screen connected to MVC and the shared PC screen display the same content. When operating on the PC, the screen connected to MVC changes synchronously.
- **Extended screen:** The screen connected to MVC and the shared PC form a complete screen, and you can use the mouse to operate the two screens. (WPP20 does not support the extended screen under the Mac system)

NOTE
 You need to install an additional driver to use the extended screen. If the Yealink Wireless Presentation Pod detects that the extended screen driver is not installed on the current PC or the driver needs to be updated, click **Install**.

2. Do one of the following to start sharing:

- Click **More** and share your desktop or a running application.
- Click **Press to share** to share your desktop.

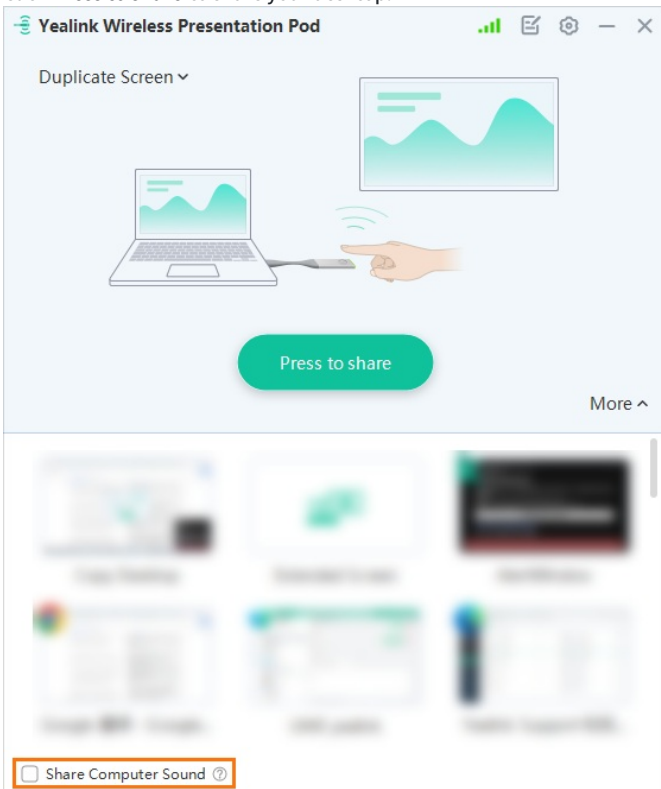

3. During content sharing, you can switch the shared content by accessing the screen sharing options in the status bar at the top of your computer screen.

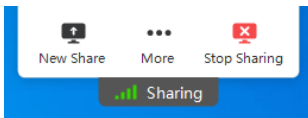

Method 3: Share via the MTouch II

Tap **Share** on the home screen or tap **Sharing Content/HDMI > Sharing to Meeting** in the meeting.

NOTE

If MVC does not immediately start content sharing, please first try enabling the content sharing feature using Method 1 or Method 2.

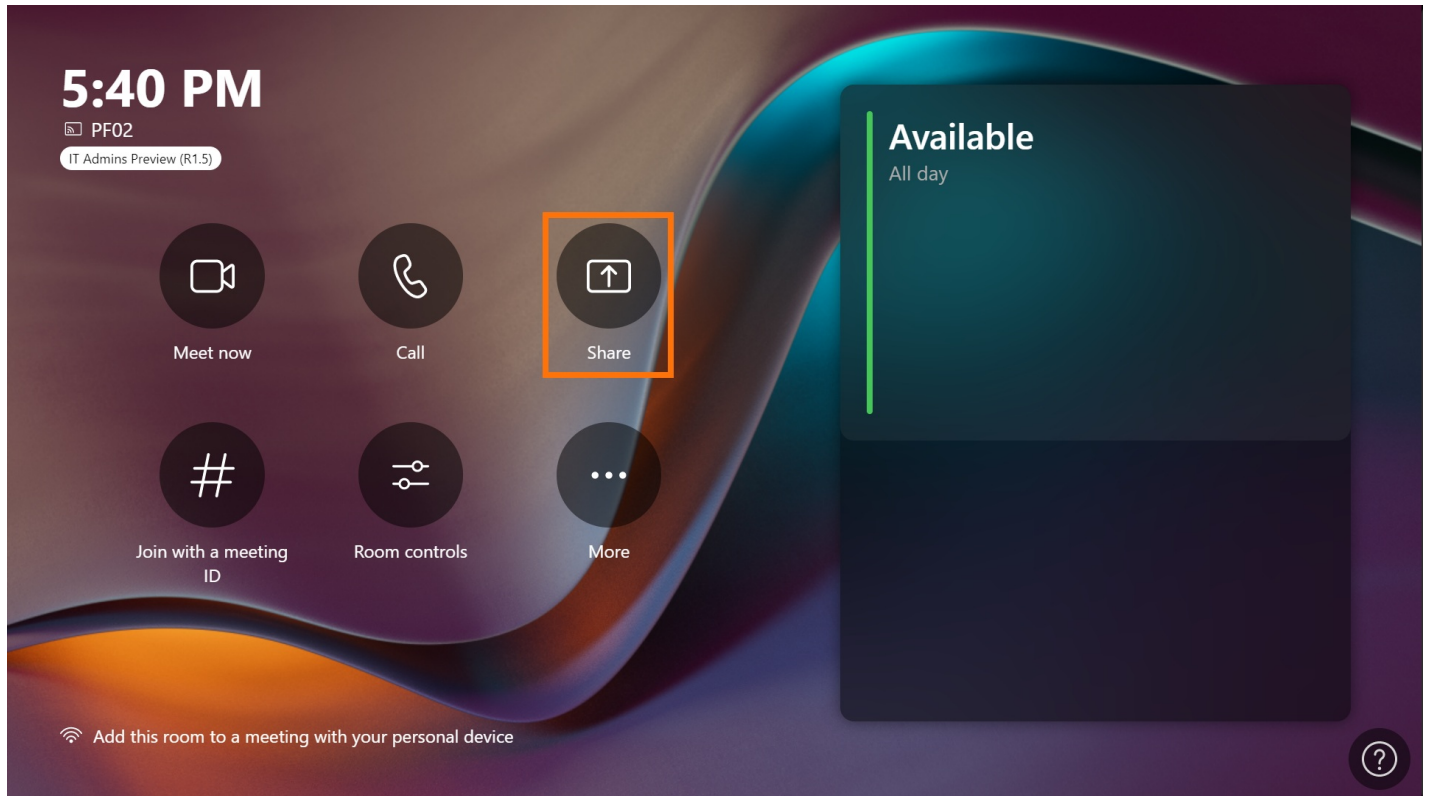

4. Share Audio

The WPP20 transmits all system audio output from your device. For example, if you have application audio notifications enabled during content sharing, participants hear these notification sounds together with the content audio.

To avoid audio interference, the system automatically mutes your local audio when you start sharing content. When you stop sharing content, the system restores your local audio to its initial status.

When using WPP20 for content sharing, click **More > Share Computer Sound** to enable audio sharing in the Yealink Wireless Presentation software.

5. Stop Sharing

Do one of the following:

- Press the **presentation** button of WPP20 again.
- Click **Stop Sharing** in the status bar at the top of your computer screen.
- Tap **Stop Sharing** button on the MTouch II.

FAQ

Failed to connect to or pair with WPP20? Failed to share content with an error code 0020001?

When you connect WPP20 to a PC, the PC does not pop up Yealink Wireless Presentation Pod. The Yealink Wireless Presentation Pod does not pop up automatically.

1. If you connect WPP20 to your PC for the first time, the Yealink Wireless Presentation Pod software does not pop up automatically. Please click **This PC > Devices and drives**.
2. Double-click CD drive to start the Yealink Wireless Presentation Pod and upgrade the firmware.

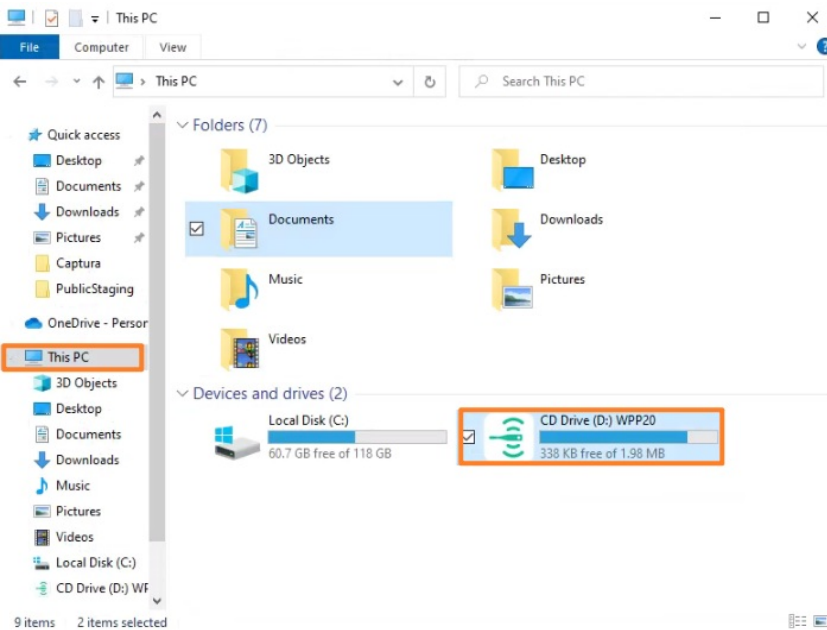

WPP20 shows the firmware differs from the MVC system version after connecting WPP20 to the PC.

If the WPP20 prompts that the firmware version differs from the MVC system version after connecting the WPP20, please click **Upgrade now**.

WPP20 pairing is successful, but content sharing on the PC is unsuccessful. It doesn't respond.

If the content sharing fails, please check whether the network connection is correct first. If the network is correct, you can upgrade the MVC system and try to share the screen again. For more information, refer to [Firmware Update](#).

WPP20 gets stuck or delayed when sharing content.

Delays and freezes may occur when sharing content via WPP20:

1. If you are connected to a 4K display, then the high-resolution display will make the CPU load of the MVC device too high, which will cause delays in screen sharing or out-of-sync audio and video during the meeting. You can set the display resolution to 1080P.
2. Your PC screen resolution is too high. An ultra-high resolution can increase the rendering burden of projected images and cause content sharing delays or buffering. In this case, please reduce the PC resolution to 1080p to resolve the issue.
3. Play 2K/4K resolution video. The WPP20 can only support a 1080p 30fps display to share screen. If you play 2K/4K or higher resolution video on your PC and share the screen of your PC simultaneously, the screen sharing speed will become very slow. In this case, please reduce the resolution of the video you are playing to 1080p or lower.
4. Network Problems. When the WPP20 works with a wireless AP, the content sharing speed will become very slow if the wireless network interferes with the environment. You need to log in as an administrator on your MVC. On the RoomConnect software, go to **MTouch II > Device Settings > Channel** to select a different channel.

Failed to install WPP20 extended screen driver.

Installing the driver requires administrator privileges. If the installation fails, please contact IT to enable your privileges and stall again.

How to use the whiteboard when sharing screens?

The MVC supports connecting the touch panel to control the whiteboard, please refer to [Microsoft Teams Rooms Document](#).

How to manually update WPP20/WPP30 software?

Whiteboard

Whiteboard

Introduction

The MVC (Microsoft Teams Room) supports connecting a touch-enabled display for whiteboard usage.

How to Use

For more information about how to operate this feature, please refer to [Using Microsoft Teams Rooms with Front of Room Touchscreens](#).

UVC30 Content Camera

Introduction

You can use the UVC30 camera as the primary camera in the meeting room or as a whiteboard camera.

When you set the UVC30 Room camera as a whiteboard camera, you can not use the PTZ control, preset position, people counting and tracking features.

For the operation video, please refer to [Whiteboard Camera](#).

How to Use

1. Enable in Yealink RoomConnect

You need to switch the system to Windows Mode (For more information, please refer to [Switch Account](#)).

1. Open the Yealink RoomConnect application and select the UVC30 card.
2. Go to **Advanced > Other**. Enable **Whiteboard Camera Mode** from the drop-down menu of **Whiteboard Camera Mode**.

2. Enable in Microsoft Teams Room System

You need to switch the system to Skype Mode (For more information, please refer to [Switch Account](#)).

1. Go to **More > Settings > Peripherals** (default password: sfb).
2. Select **Yealink UVC30 Camera** from the drop-down menu under **Content Camera**.

Demonstration Effect:

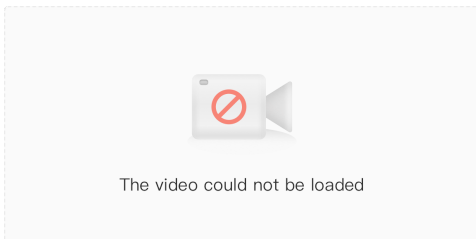

FAQ

The UVC30 camera can not be used? Is the MVC not detecting UVC30?

Please check whether the whiteboard camera feature is disabled.

Does MVC support using a touch display as a whiteboard? How to use the whiteboard feature?

MVC supports connecting a touch display to use it as a whiteboard. For the method, please refer to [Using Microsoft Teams Rooms with Front of Room Touchscreens](#).

Camera Controls

Camera Basic Settings

Introduction

During a meeting, you can control your local HD camera with Pan-Tilt-Zoom (PTZ) functionality, which allows you to control your camera locally. It is also possible to control far-end cameras through the Zoom Rooms controller and save camera presets.

How to Use

You can directly use the MTouch II matched with MVC to operate or log in to the Yealink Device Management Platform to operate remotely. For the remote control, please refer to [Remote Control](#).

Select Camera

You need to switch the system to Windows Mode (For more information, please refer to [Switch Account](#)).

Open the Yealink RoomConnect application and select the camera card.

The screenshot shows the Yealink RoomConnect application window. The title bar includes the Yealink logo, the text "Yealink RoomConnect", and standard window controls (gear, minus, and close). The main content area displays four camera cards in a 2x2 grid:

- UVC86 (1)**: Firmware Version: 151.431.254.239, Hardware Version: 151.0.81.1.2.0.0, Serial Number: 806009E120002140.
- UVC86**: Firmware Version: 151.431.0.15, Hardware Version: 151.0.80.1.0.0.0, Serial Number: 506009D090000097. This card is highlighted with an orange border and has a green arrow icon to its right.
- CP700**: Firmware Version: 100.420.0.45, Hardware Version: 100.1.112.0.0.0.0, Power: 100%, Serial Number: 5801219060000151.
- MTouchII**: Firmware Version: 126.410.0.85, Hardware Version: 126.2.0.0.2.0.17, Serial Number: 803061E020002244.

Change Camera Name

Go to **Device Status > Equipment Model**.

Device Settings

Go to **Device Settings > General Settings**.

Yealink RoomConnect



← Return



UVC86

- ☰ Device Status
- 🔗 Device Settings
- 🖥️ Image Setting
- 🏠 Update Device
- 🛎️ Device Support
- 🔊 Audio Settings



- General Settings >
- Advanced Settings >

- Lens Calibration ⊕
- Tracking Feature
- PIP Mode
- Presets
- +
New Preset

Setting	Description
Noise Block	Enabling this feature, the camera can block sound except the speaker' s voice. Default: Disable.
Upside Down	Enabling this feature, the camera' s image will be displayed upside down. This mode is suitable when the camera is mounted on the ceiling of the meeting room. Default: Disable.
Camera Pan Direction	Setting the camera pan direction to Normal or Reverse . When it is set to Reverse , the camera pans opposite the direction key. Default: Normal.
People Counting	Enabling this feature, the camera will capture the number of people in the meeting room and display it in the upper-right corner of the video picture. Default: Disable.

Graphics Settings

1. Select **Graphics Settings** to set the camera image-related parameters respectively for the **Main Camera/Panoramic Camera**.

Yealink RoomConnect
⚙️ | — | ✕

← Return



UVC86

- ☰ Device Status
- 🔗 Device Settings
- 📺 Image Setting
- 🏠 Update Device
- 🛎 Device Support
- ☰ Audio Settings



Exposure Mode Auto Exposure ▾

Flicker 50HZ ▾

White Balance Mode Auto ▾

Reset Camera
Save

2. If you want to restore the default settings, select **Reset Camera** and **Save**.

Yealink RoomConnect
⚙️ | — | ✕

← Return



UVC86

- ☰ Device Status
- 🔗 Device Settings
- 📺 Image Setting
- 🏠 Update Device
- 🛎 Device Support
- ☰ Audio Settings



Exposure Mode Auto Exposure ▾

Flicker 50HZ ▾

White Balance Mode Auto ▾

Reset Camera
Save

Parameters	Description
Exposure Mode	You can select the following to set: Auto Exposure, Manual Exposure, Shutter Priority and Brightness Priority. Default: Auto Exposure.
Flicker	In a lighting environment such as an incandescent lamp, the camera picture may appear to power frequency flicker, so it is necessary to enable this feature. But you do not need to enable it in a natural light environment. Default: 50Hz.

White Balance Mode	To display high-quality video images, you can select the following to set: Auto, Incandescent, Fluorescent, Indoor and Outdoor. Default: Auto.
Display Image	To display high-quality video images, you can select the following to set: Standard, Mild, Custom and High Definition. In custom mode, saturation and sharpness parameters are automatically adjusted. Default: Standard.
Saturation	The saturation means the maximum intensity of color in the image. Default: 50.
Sharpness	The sharpness is an indicator that reflects the definition of the image plane and the sharpness of the image edge. Increasing the sharpness will improve the definition of the image. However, the image will look distorted and glaring if the sharpness is too high. Default: 15.
2D (Noise Reduction)	Enabling this feature to reduce redundant interference information in image data. Default: Enable.

FAQ

You can't enable the People Counting in the Presenter Tracking mode.

The Presenter Tracking mode does not support the People Counting feature.

You feel that the picture is not clear or blurred, or there is a halo in the picture. You feel that the picture is not clear or blurred. There is a halo in the graphics.

When the picture is unclear or has a halo, you can check whether there are stains or fingerprints on the lens surface, and wipe them clean with lens paper or a wet paper towel. The clarity can also be improved by adjusting the image mode or sharpness. If the camera picture is still blurred, please contact Yealink Technical Support.ort.

Manual Controls

Introduction

During a meeting, you can control your local HD camera with Pan-Tilt-Zoom (PTZ) functionality, which allows you to control your camera locally. It is also possible to control far-end cameras through the Zoom Rooms controller and save camera presets.

How to Use

You can directly use MTouch II matched with MVC to operate or log in to the Yealink Device Management Platform to operate remotely. For the remote control, please refer to [Remote Control](#).

You need to switch the system to **Windows Mode** (For more information, please refer to [Switch Account](#)).

Method 1: Use Yealink RoomConnect to Control

1. Open the Yealink RoomConnect application and select the camera card.
2. Select **Device Settings** to disable **Tracking Feature**. Then use your mouse or finger to adjust the camera direction and focal length.

Yealink RoomConnect ⚙️ | — | ×

← Return



UVC86

- ☰ Device Status 1
- 🔗 Device Settings
- 📺 Image Setting
- 🏠 Update Device
- 🛎 Device Support
- 📶 Audio Settings



⬆
🔍 | 🔍

⬅
⬇
➡
🔄 Reset

3

- General Settings >
- Advanced Settings >

- Lens Calibration 2 +
- Tracking Feature
- PIP Mode
- Presets
- +
New Preset

NOTE
Click  to reset the camera.

Method 2: Use Microsoft Teams Rooms to Control

When you are not in the meeting:

1. Select **Room Controls** to enter **Camera Control**.
2. Select **Off** to disable **Tracking Feature**. Then use your mouse or finger to adjust the camera direction and focal length.

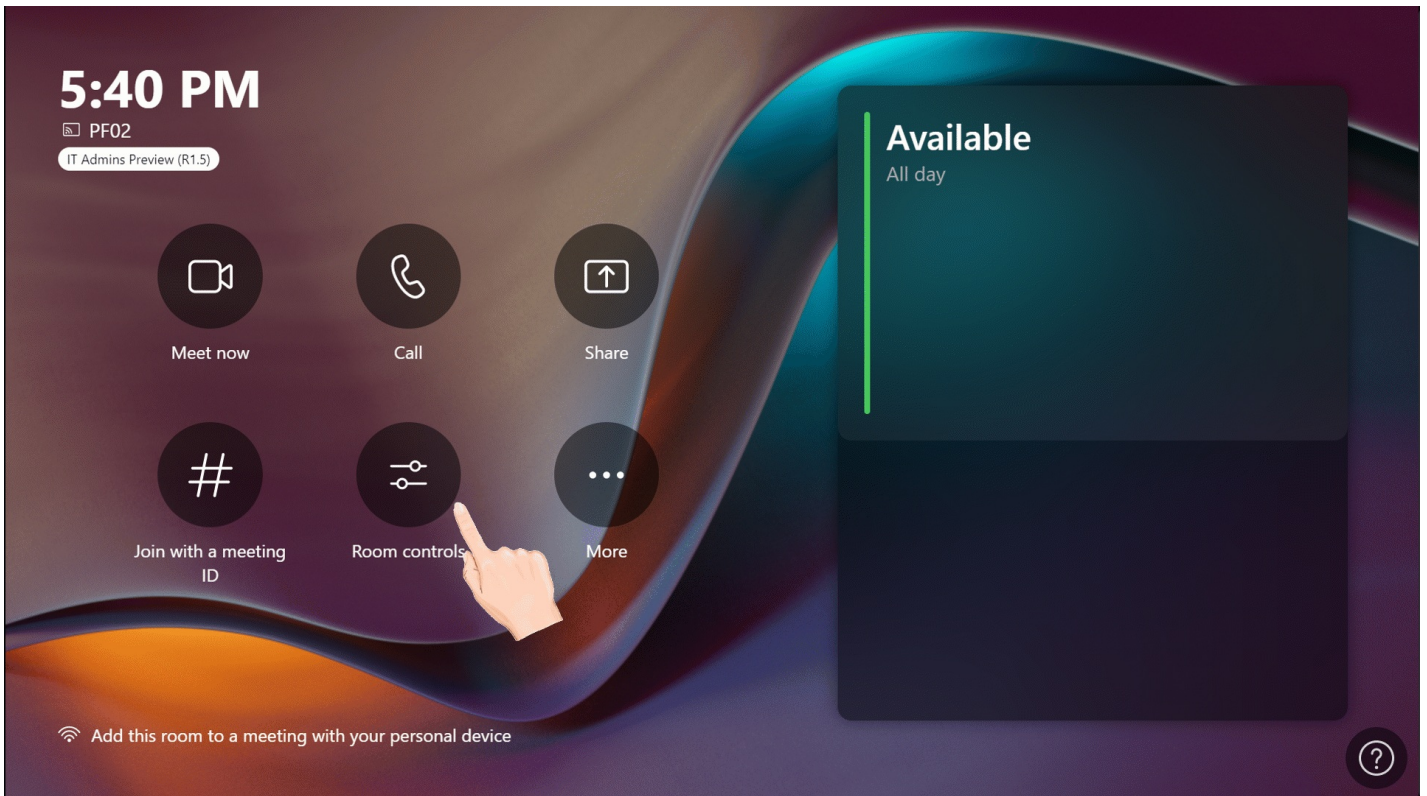

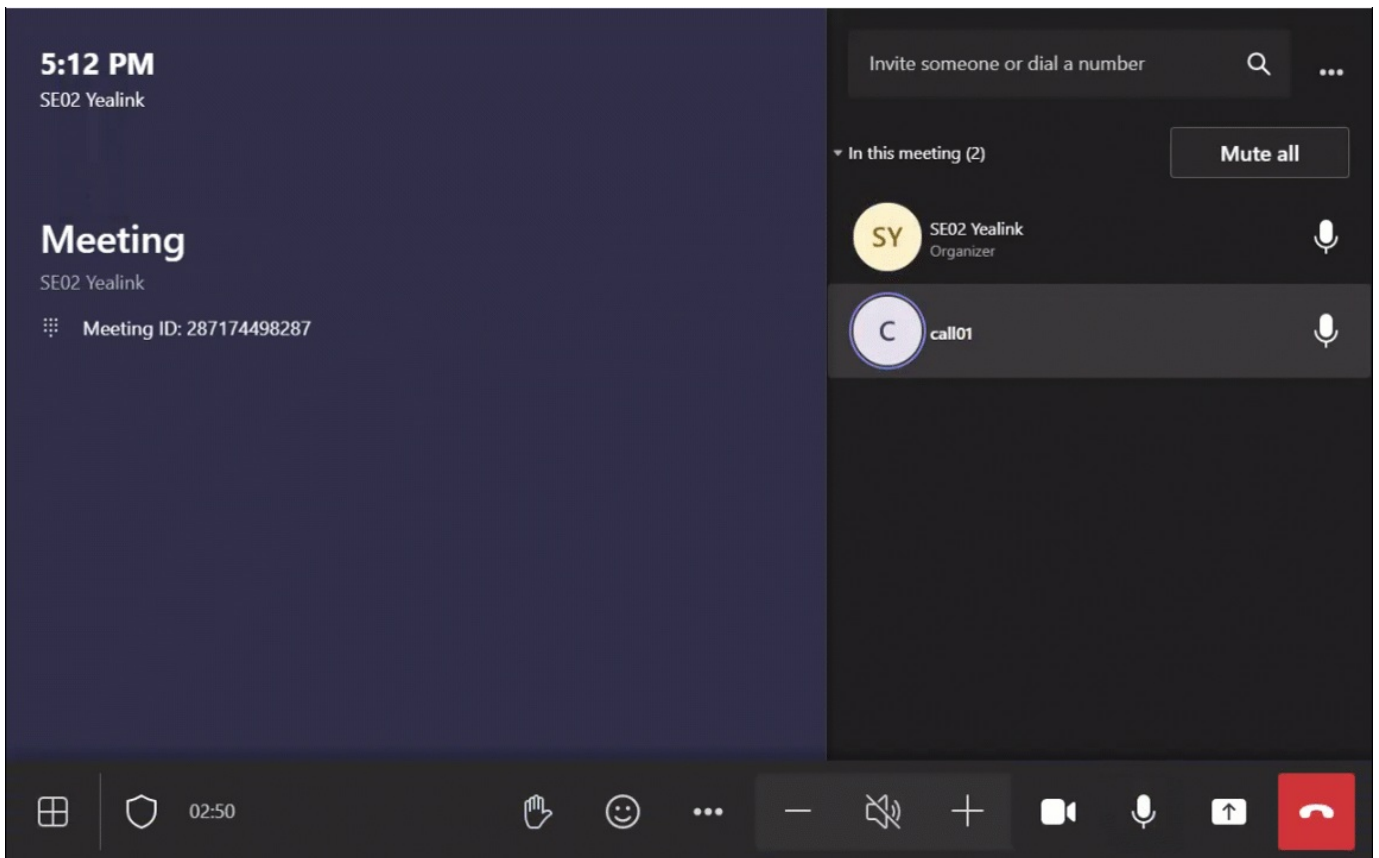

When you are in the meeting:

1. Select **More > Room Controls**.
2. Select **Off** to disable **Tracking Feature**. Then use your mouse or finger to adjust the camera direction and focal length of the camera.



FAQ

When you adjust the camera, you can not center participants on the screen center.

1. Select **Device Settings > General Settings > Camera Pan Direction** to check whether the setting is **Normal** or **Reversed**.
2. If the setting is **Normal**, select  to adjust when the participant is to the right.
If the setting is **Reversed**, select  to adjust when the participant is to the right.

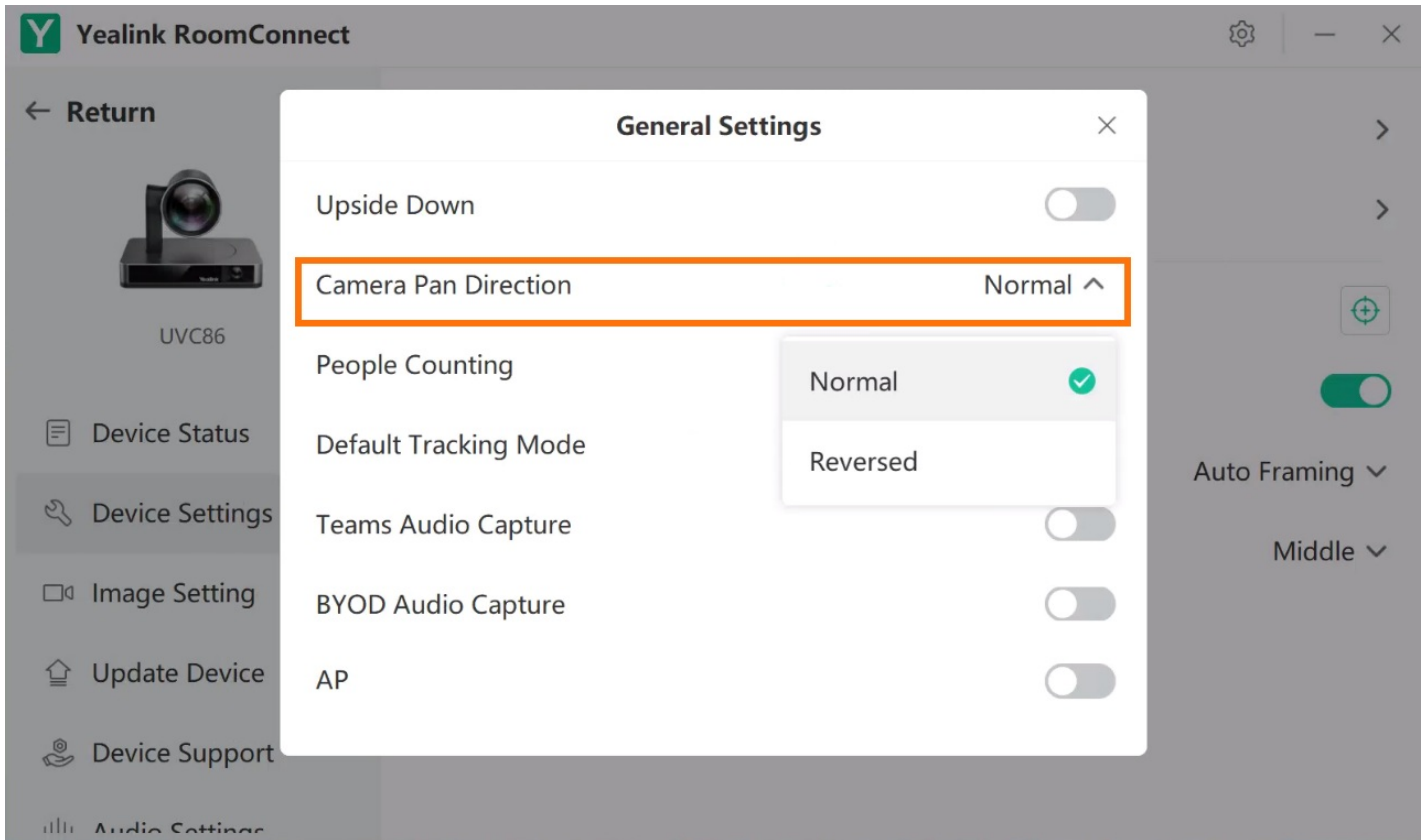

How to enable/disable the Tracking Feature?

Does MVC/ZVC support remote cameras?

Camera Preset

Introduction

You can set the camera preset in advance using the manual control mode. Presets specify the settings of the camera's angle and focal length that can be used to point a camera at a pre-defined location quickly.

- The camera preset is only supported in manual control mode. Please make sure that you have disabled the **Tracking Mode**.
- You can create up to 9 preset positions for the UVC cameras.
- The multiple cameras in the MVC940/MVC900II/MVC900 system are independent, and the configuration of a single camera will not affect the configuration of other cameras.

How to Use

- You can directly use MTouch II matched with MVC to operate or log in to the Yealink Device Management Platform to operate remotely. For the remote control, please refer to [Remote Control](#).
- Steps 1 - 4 of this chapter are setting the camera preset in the Yealink RoomConnect application, and the steps are in no order. Step 5 is applying the camera preset in the Microsoft Teams System. If the administrator has configured the camera preset in advance, you can directly apply the camera preset for a conference.

1. Create Camera Preset

You need to switch the system to **Windows Mode** (For more information, please refer to [Switch Account](#)).

1. Open the Yealink RoomConnect application and select the camera card.
2. Select **Device Settings** to adjust the camera position and focal length.
3. Select **New Preset**.

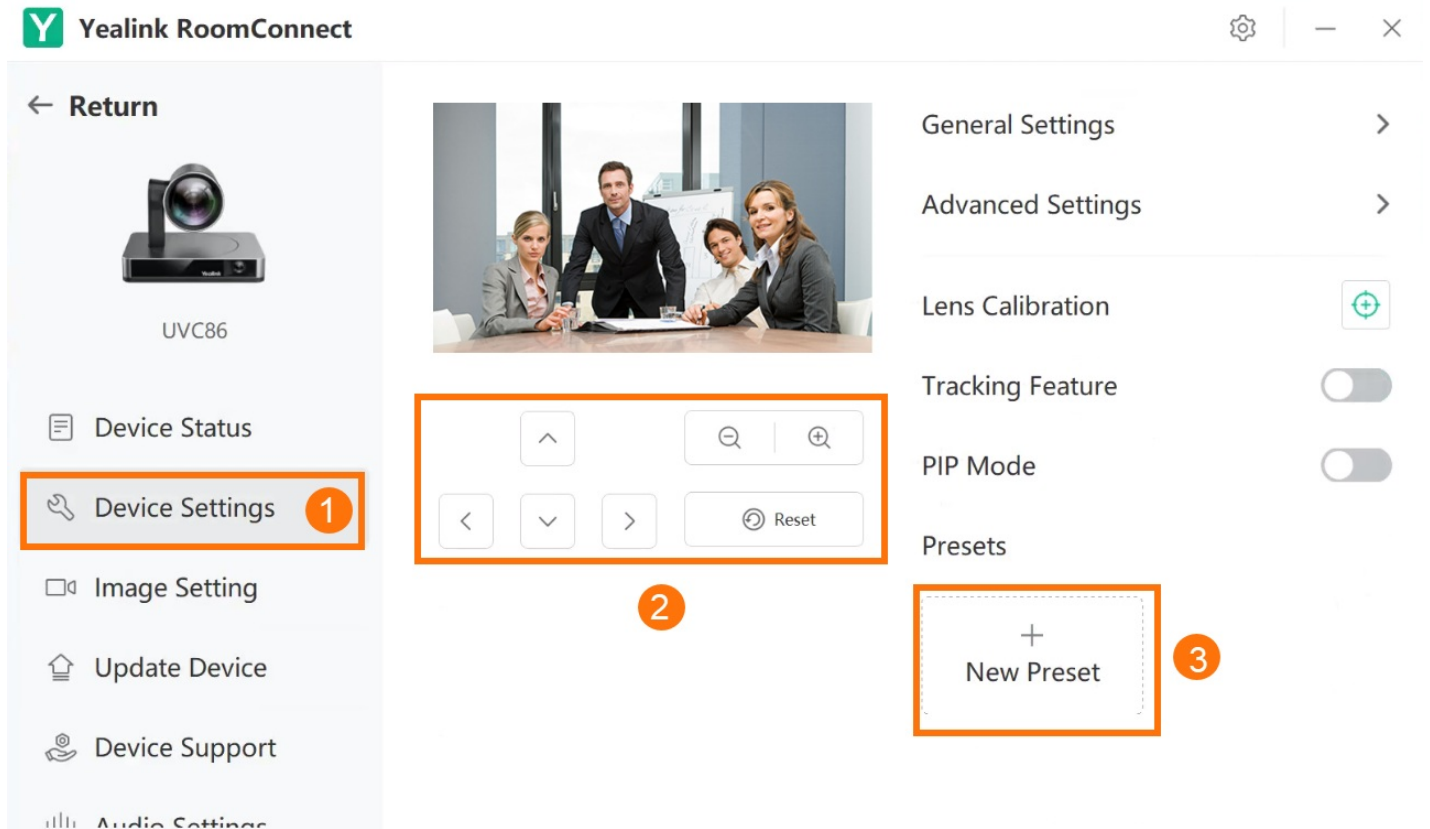

2. Customize Camera Preset

Select  in the upper-right corner of the camera preset:

- Click **Edit Name** to edit the name of the camera preset.
- Click **Set as Default** to set the camera preset as the default.
- Click **Delete** to delete a camera preset.

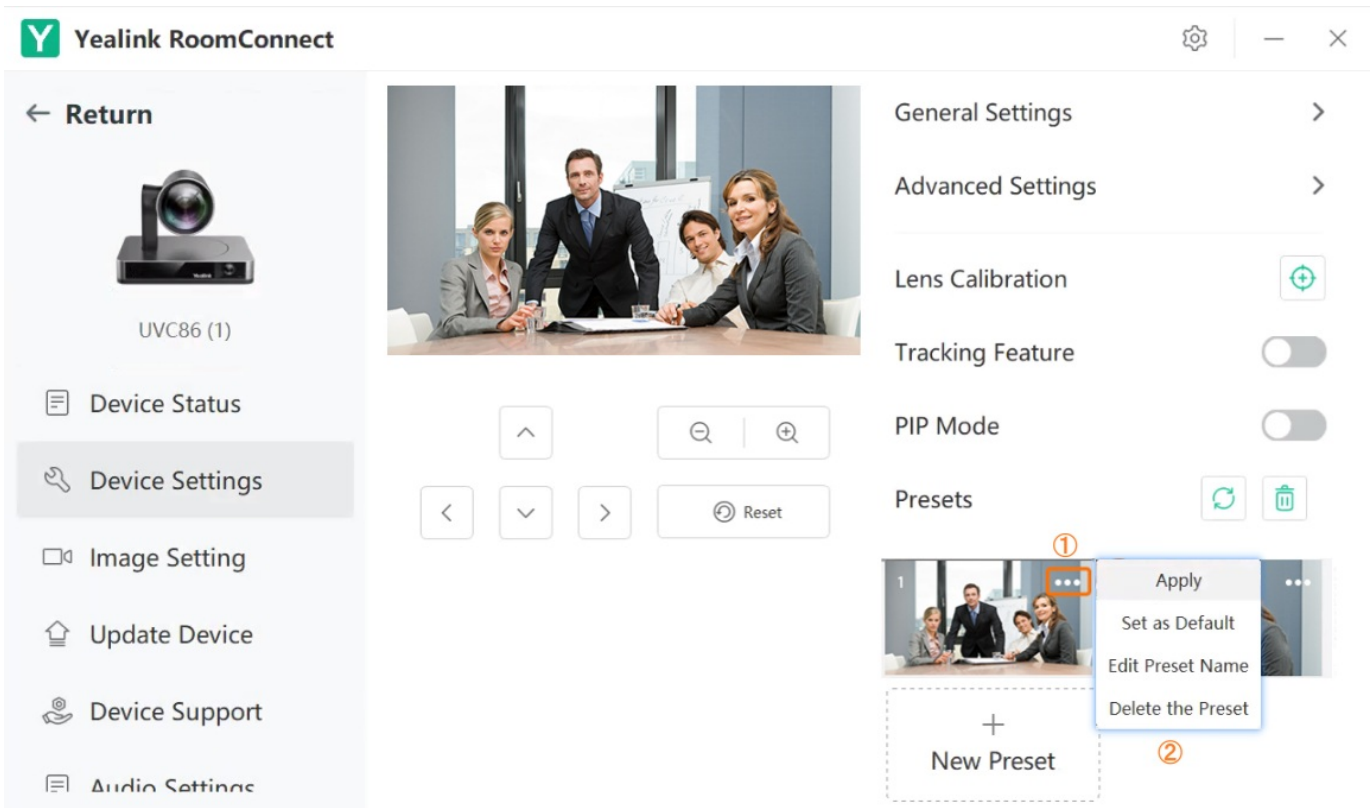

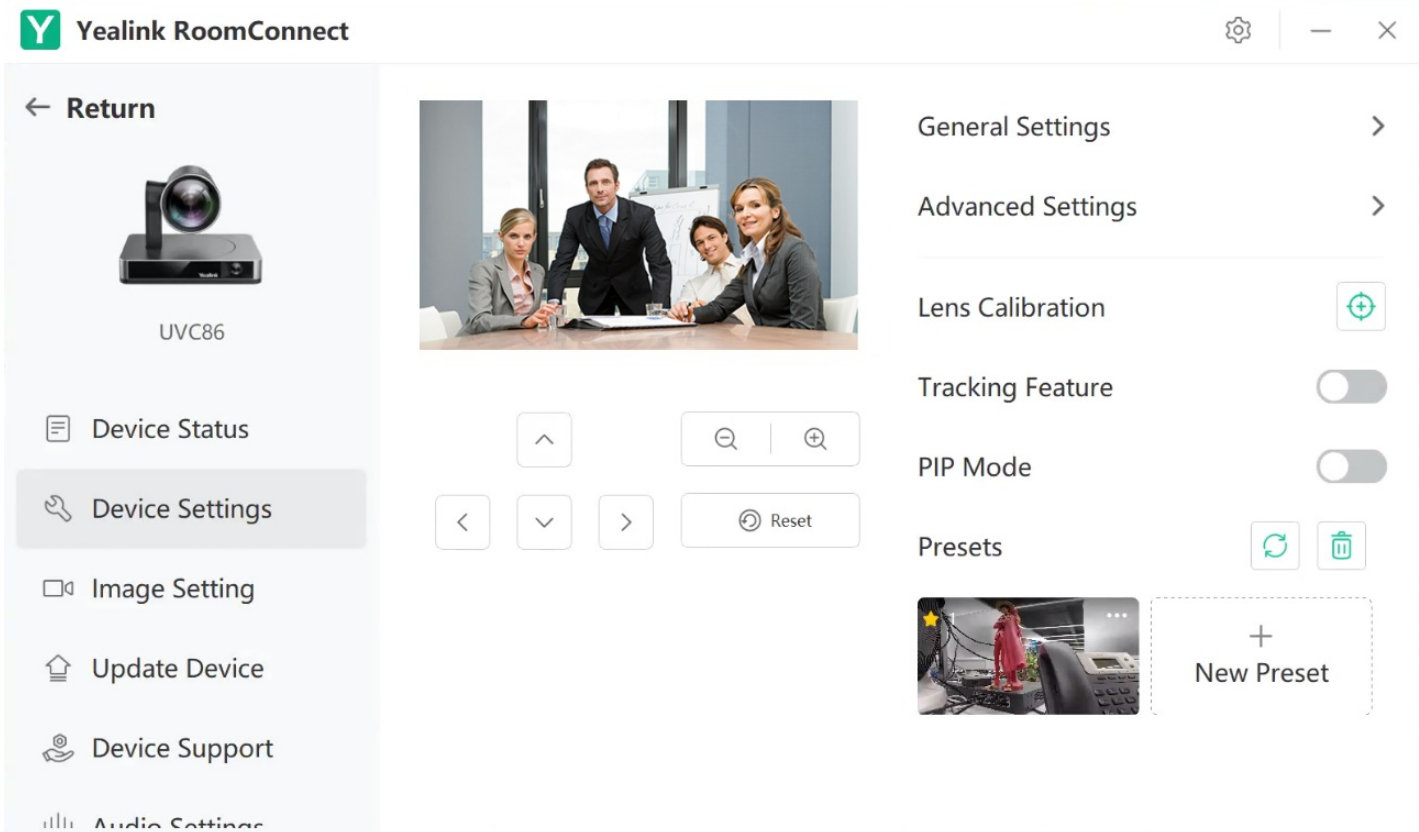

As shown in the following figure, the preset name is displayed in the upper-left corner. When a camera preset is set as default, there is a  in the upper-left corner.



3. Update/Clear All Presets

When the camera position changes, the camera preset will change accordingly. In this case, you need to update the preset position. If the updated camera preset differs from what you expected, you can clear and reset all the cameras.

Select  /  to update or clear all camera presets.

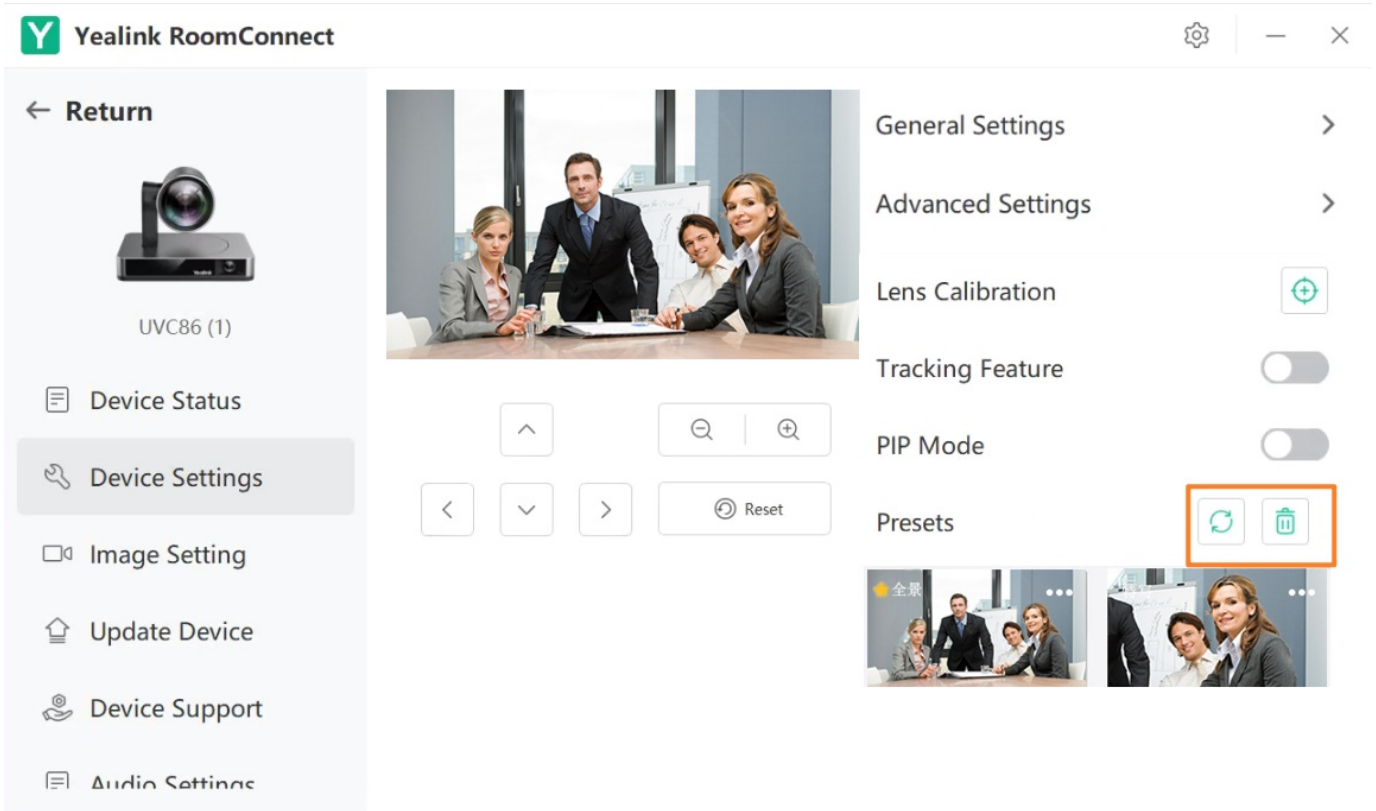

4. Apply Camera Preset

When you are not in the meeting:

1. Select **Room Controls** to enter **Camera Control**.
2. Use your mouse or finger to apply the camera preset.

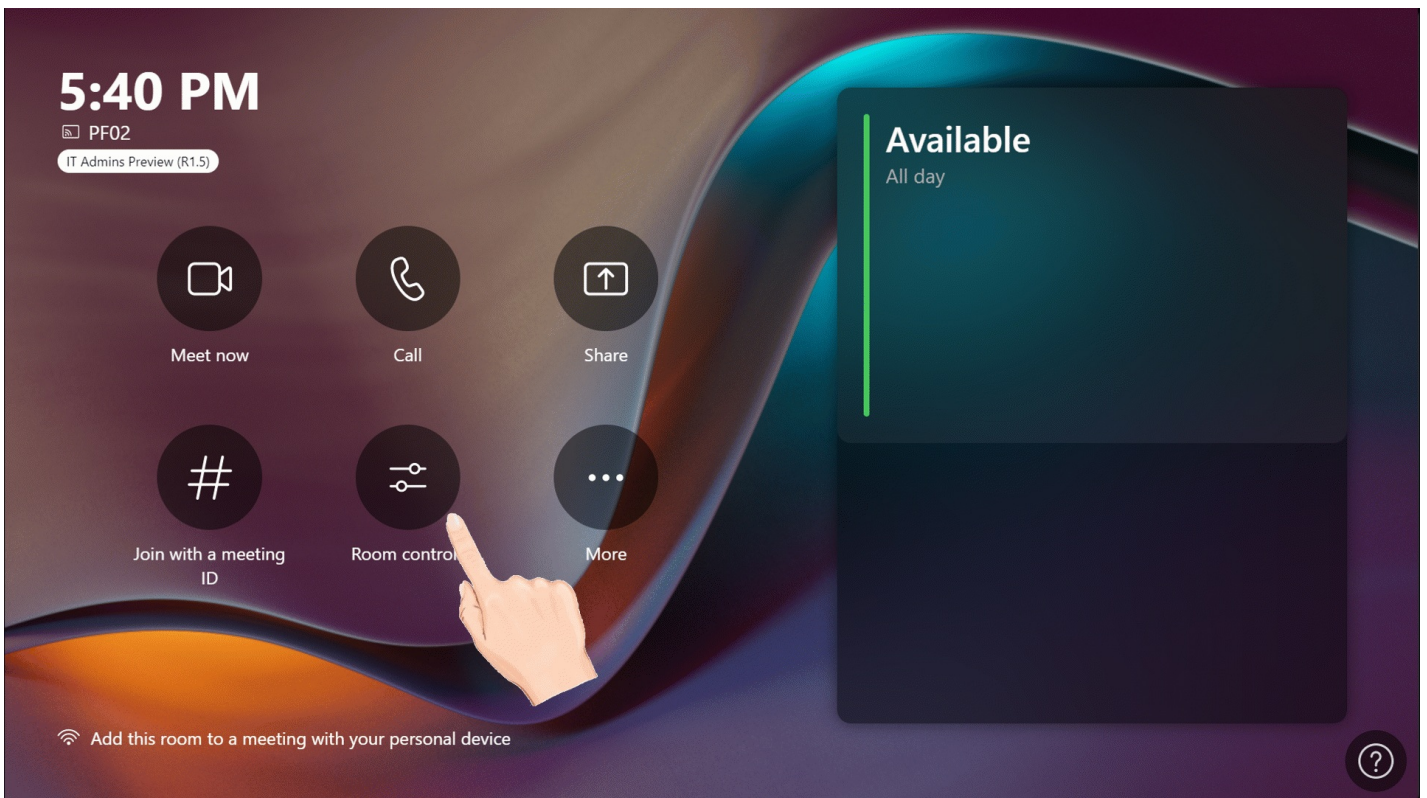

When you are in the meeting:

1. Select **More** to go to **Camera Control > Room Controls**.

2. Use your mouse or finger to apply the camera preset as your need.

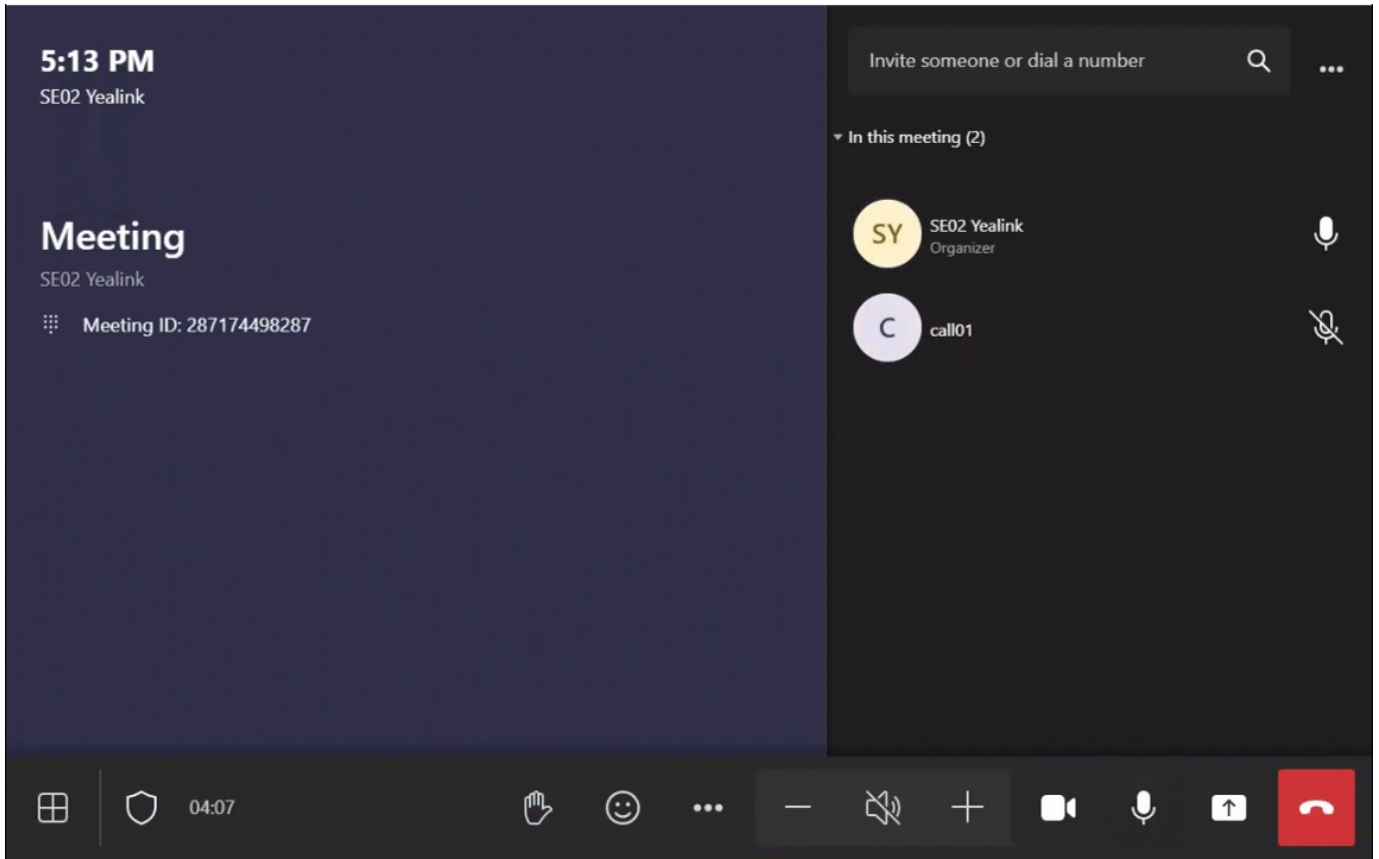

FAQ

I can not find the interface for creating a camera preset. Where do I create a new camera preset?

The camera preset is only supported in manual control mode. Please make sure that you have disabled the **Tracking Feature**.

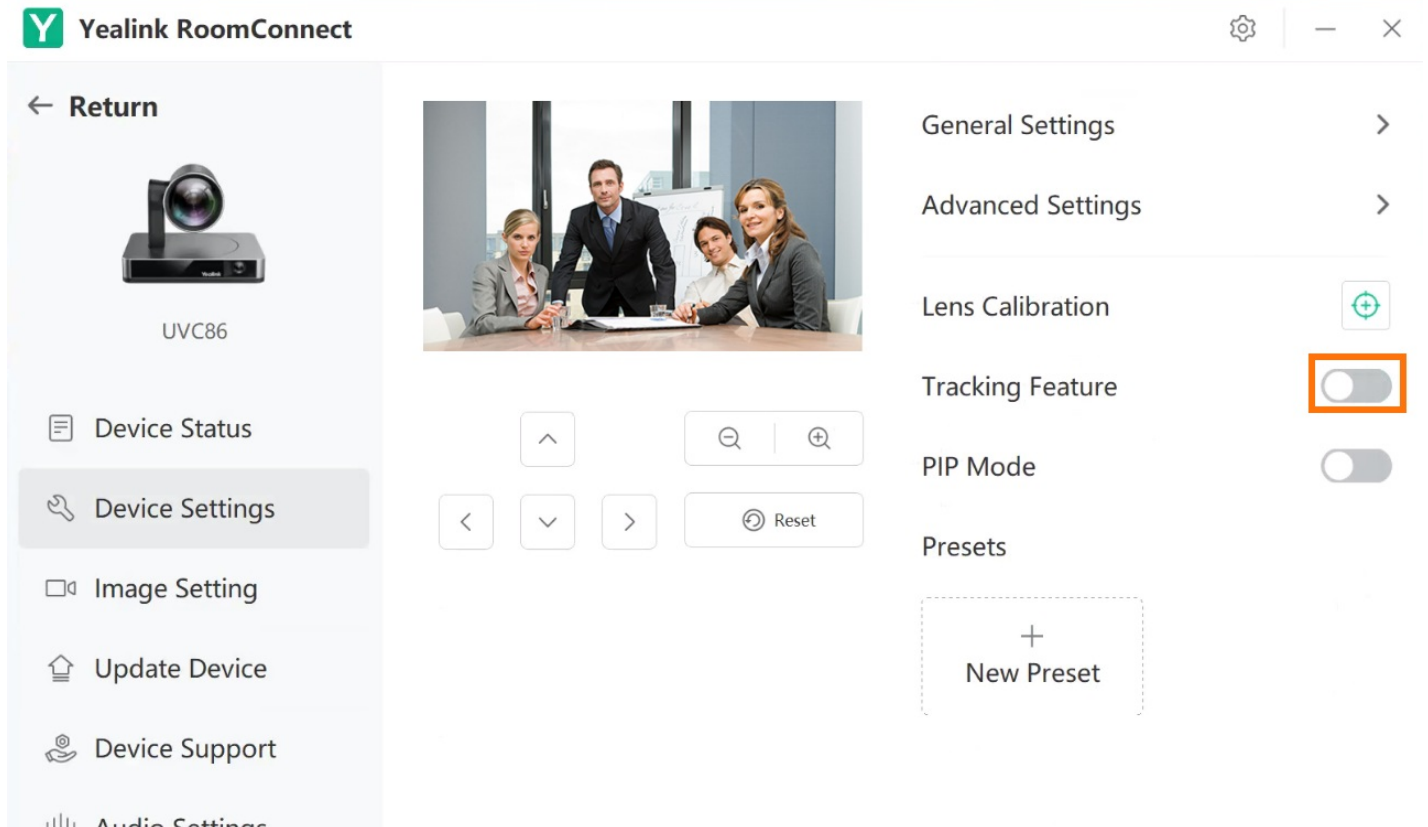

How do I set the camera preset using the VCR20 remote control?

For more information, please refer to [VCR20](#).

Auto Framing

Introduction

Auto Framing of Individuals Based on Human Detection, achieving real-time detection and location tracking of all participants in the meeting. It can automatically adjust the camera to encompass all participants within the frame based on changes in the number and positions of attendees. For the operation video, please refer to [Camera Features](#).

NOTE

The camera cannot be adjusted manually in the Tracking mode.

How to Use

You can directly use MTouch II matched with MVC to operate or log in to the Yealink Device Management Platform to operate remotely. For the remote control, please refer to [Remote Control](#).

You need to switch the system to Windows Mode (For more information, please refer to [Switch Account](#)).

1. Enable Speaker Tracking

1. Open the Yealink RoomConnect application and select the camera card.
2. Go to **Device Settings > Tracking Feature > Tracking Mode**.

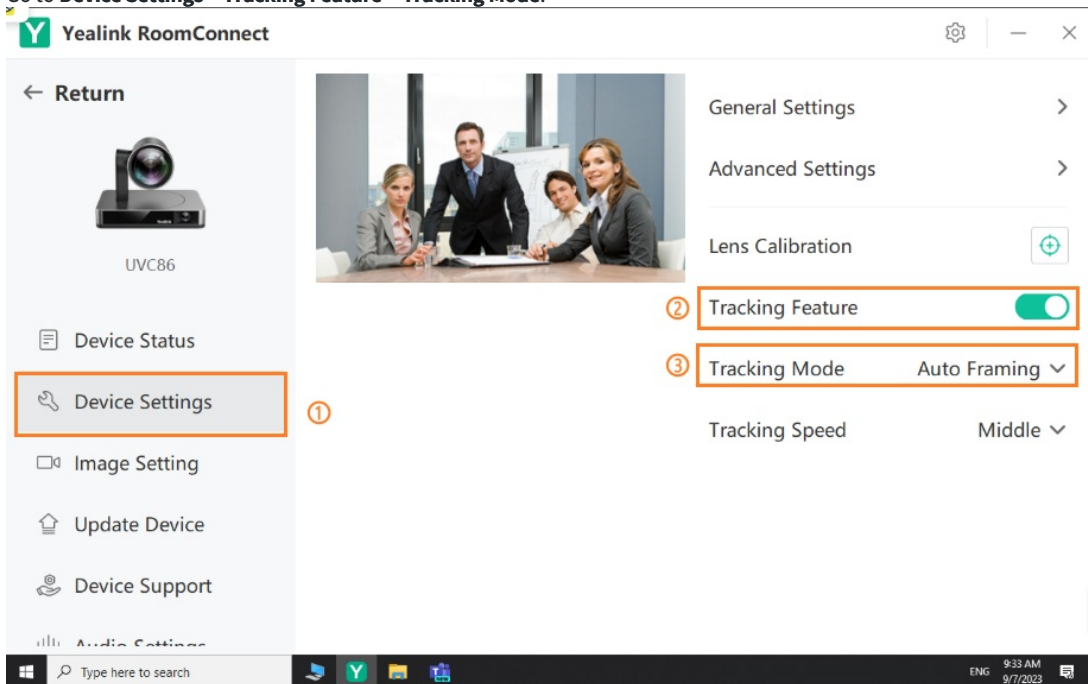

2. Enable Speaker Tracking in Microsoft Teams

Before the meeting:

1. Select **Room Controls** to enter Camera Control.
2. Select to enable **Auto Framing**.

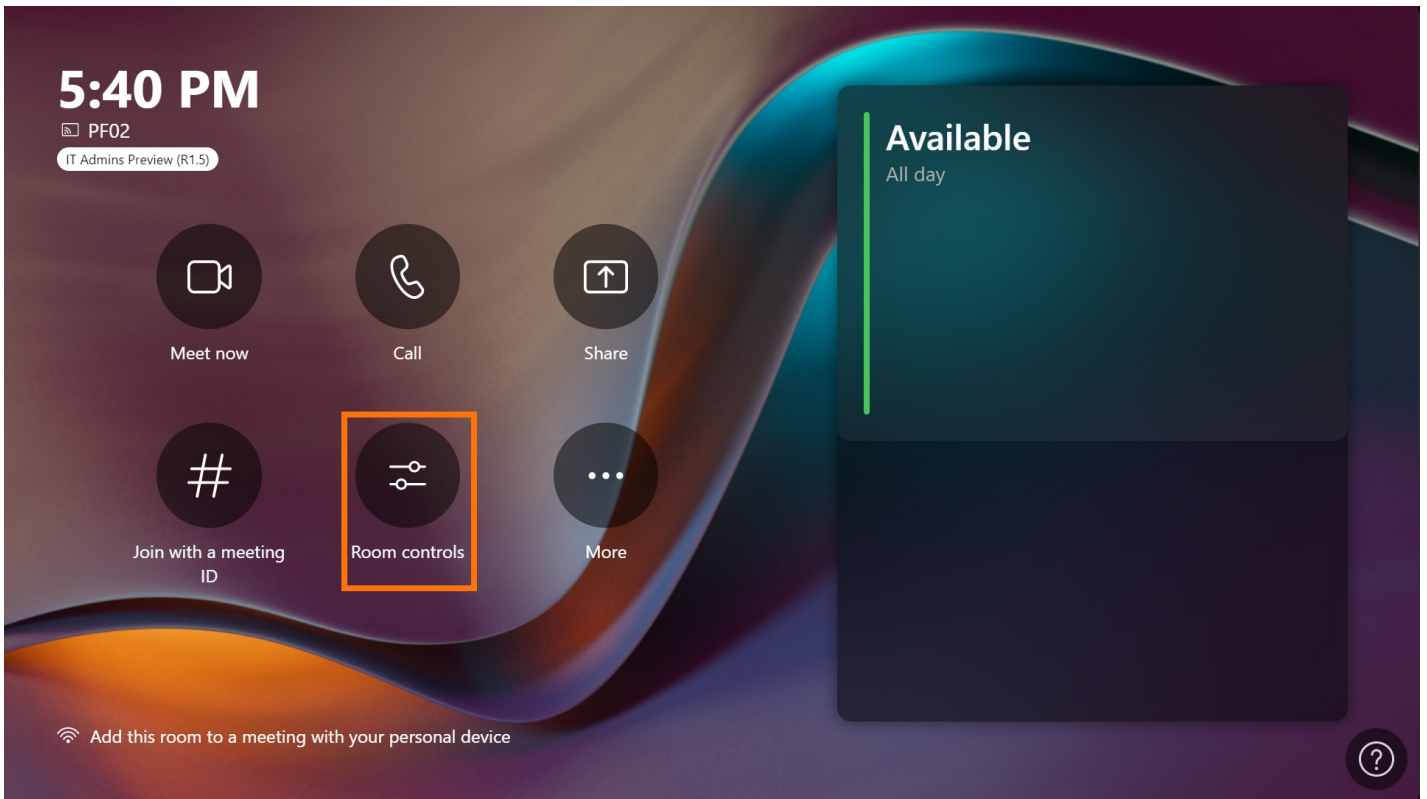

During the meeting:

1. Select to enter Camera Control > Room Controls.
2. Select to enable **Auto Framing**.

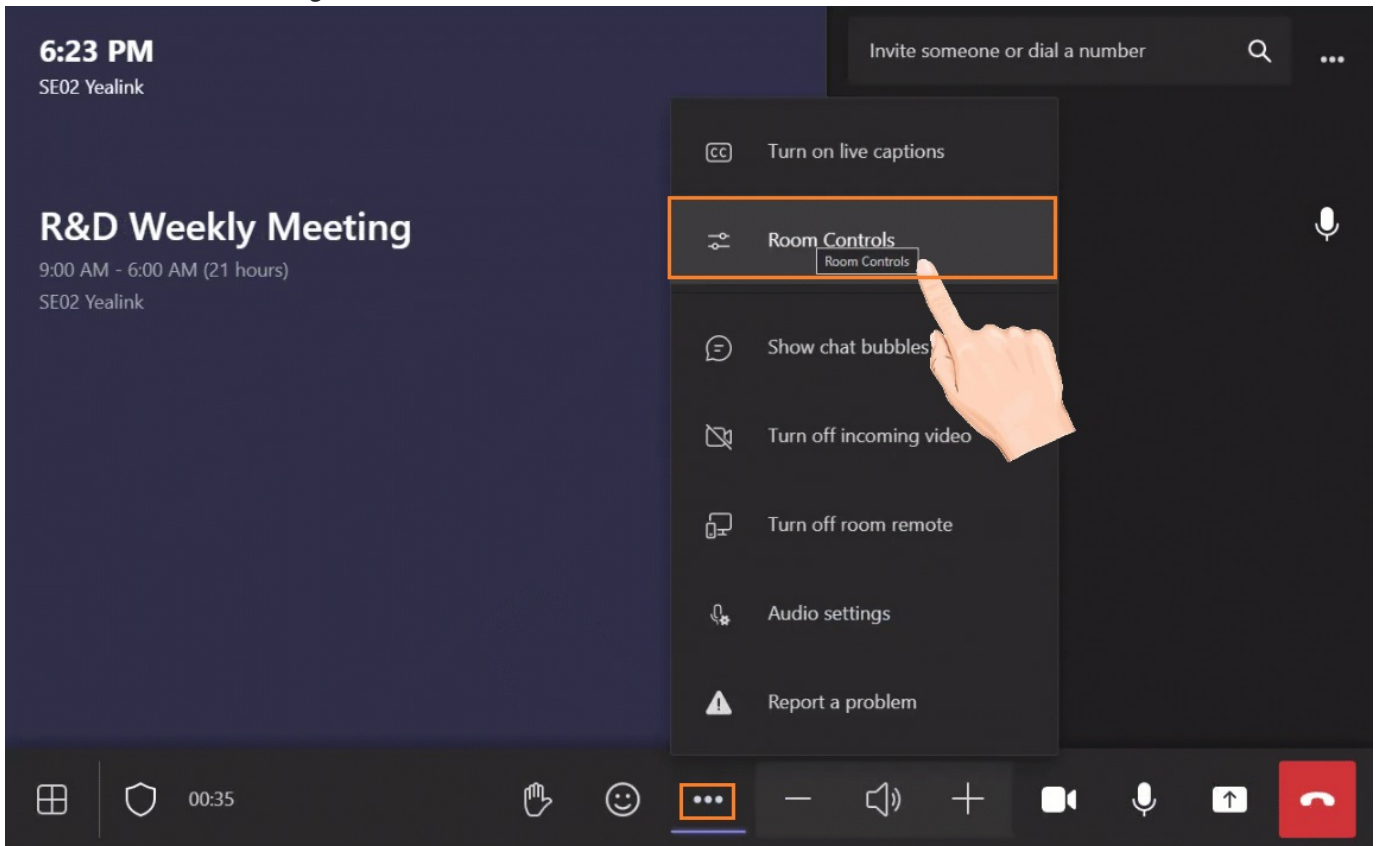

Speaker Tracking

Introduction

When the tracking camera locates a person speaking, the camera switches to a close-up of that person.

NOTE
It is only applicable to UVC86/UVC40.

How to Use

- You can directly use MTouch II matched with MVC to operate or log in to the Yealink Device Management Platform to operate remotely. For the remote control, please refer to [Remote Control](#).
- Steps 1 - 4 of this chapter set camera, and step 5 applies the configuration. If the administrator has configured the camera in advance, you can directly go to step 5 to apply the Conversation Mode in the Microsoft Teams System.

1. Lens Calibration

NOTE
When you calibrate the lens, please ensure that there are no other things within 3 meters in front of the lens. Otherwise, it will be prompted that **Lens calibration failed, please try to recalibrate.**

You need to switch the system to **Windows Mode** (For more information, please refer to [Switch Account](#)).

1. Open the Yealink RoomConnect application and select the camera card.
2. Select **Device Settings**.
3. Select **Lens Calibration**.

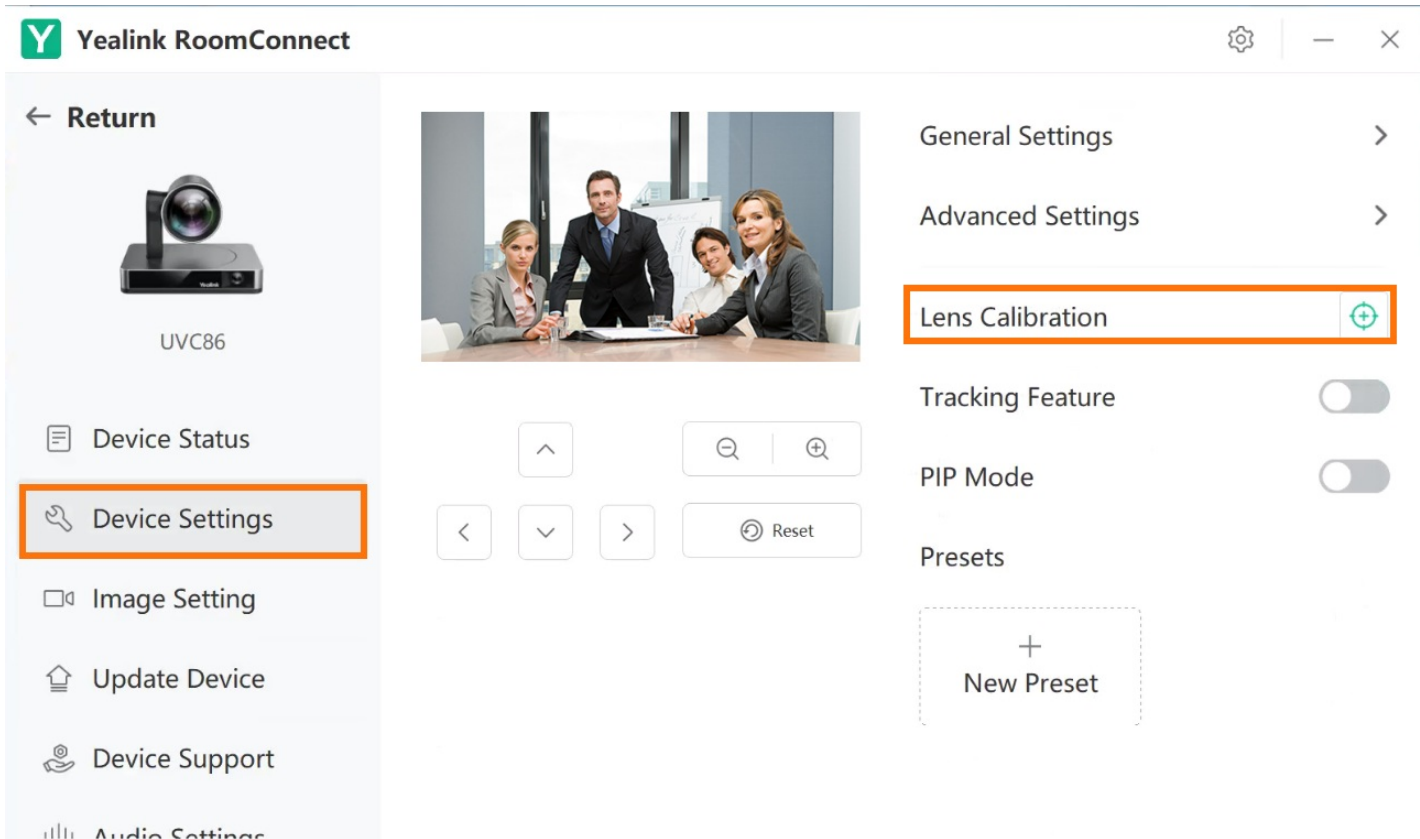

2. Enable Speaker Tracking

1. Enable **Tracking Feature**.
2. Select **Speaker Tracking** in **Tracking Mode**.



Yealink RoomConnect [Settings] [Close]

← Return

 UVC86

- Device Status
- Device Settings**
- Image Setting
- Update Device
- Device Support
- Audio Settings



- General Settings >
- Advanced Settings >
- Lens Calibration 
- Tracking Feature 
- Tracking Mode Auto Framing ^
- Tracking Speed
 - Auto Framing 
 - Speaker Tracking
 - Presenter Tracking
 - Multi Focus

3. Set Tracking Speed

Go to **Tracking Speed** and select **Fast/Middle/Slow**.

- **Fast:** The camera tracks the speaker at a faster speed.
- **Middle:** The camera will track the speaker at average speed.
- **Slow:** The camera tracks the speaker at a slower speed.



Yealink RoomConnect [Settings] [Close]

← Return

 UVC86

- Device Status
- Device Settings**
- Image Setting
- Update Device
- Device Support
- Audio Settings



- General Settings >
- Advanced Settings >
- Lens Calibration 
- Tracking Feature 
- Tracking Mode Auto Framing v
- Tracking Speed Middle ^
 - Fast
 - Middle **
 - Slow

4. Enable/Disable Conversation Mode

In this mode, the camera automatically tracks the current speaker in the room using a Speaker Tracking algorithm. Conversation Mode frames two speakers separately and puts them on the same window in a split view.

- When only one participant speaks, the camera only focuses on the speaker.
- The camera frames the two participants to avoid the bad experience caused by frequent camera switching when both speakers talk at the same time.
- One of the speakers talks too little or too much, and the camera will stop the Conversation Mode and refocus on one participant.
- The Conversation Mode automatically ends when a third participant starts talking.

NOTE

It is only applicable to the UVC86 camera.

5. Enable Speaker Tracking in Microsoft Teams

You need to switch the system to **Windows Mode** (For more information, please refer to [Switch Account](#)).

When you are not in the meeting:

1. Select **Room Controls** to enter **Camera Control**.
2. Select to enable **Speaker Tracking**.

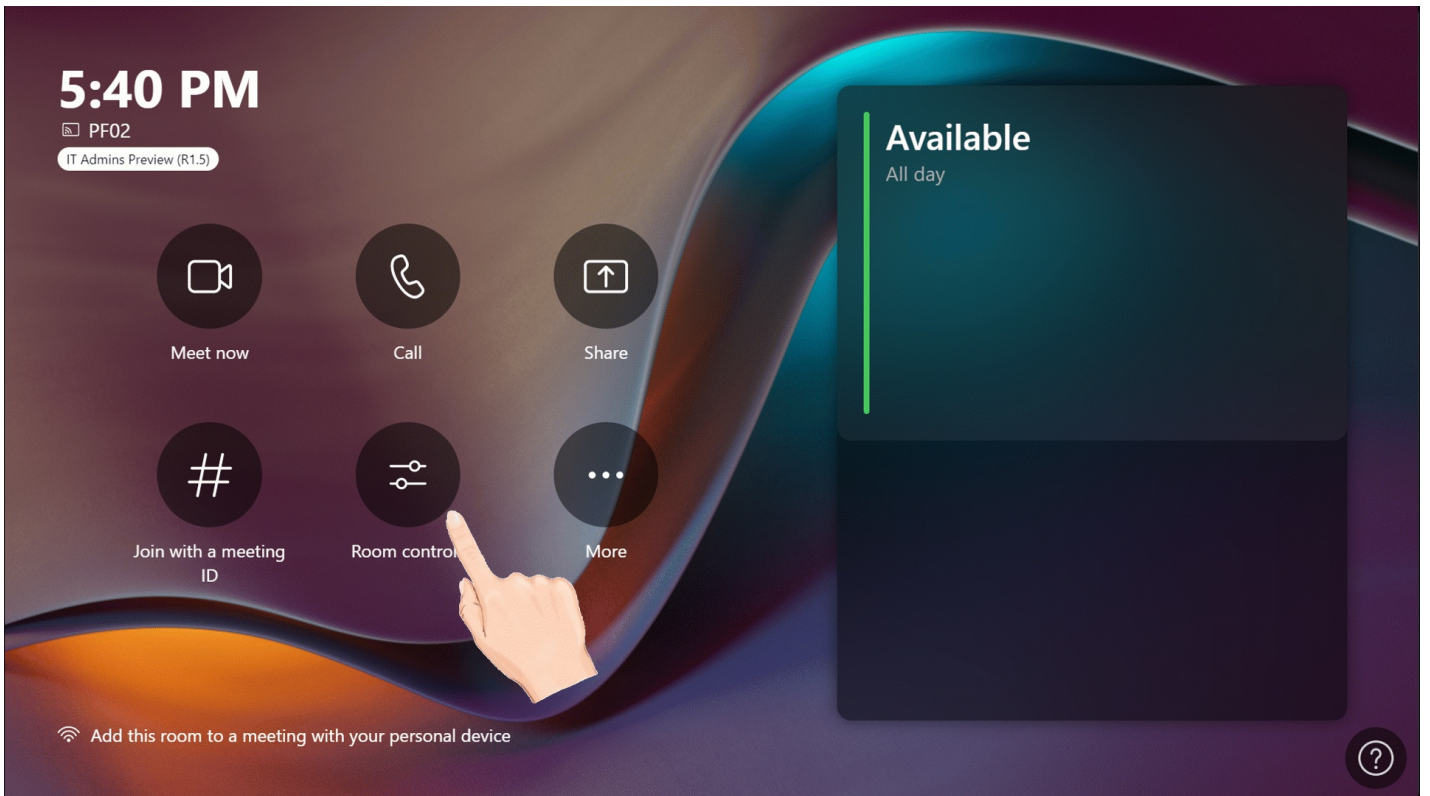

When you are in the meeting:

1. Select **Room Control** to enter **Camera Control > Room Controls**.
2. Select to enable **Speaker Tracking**.

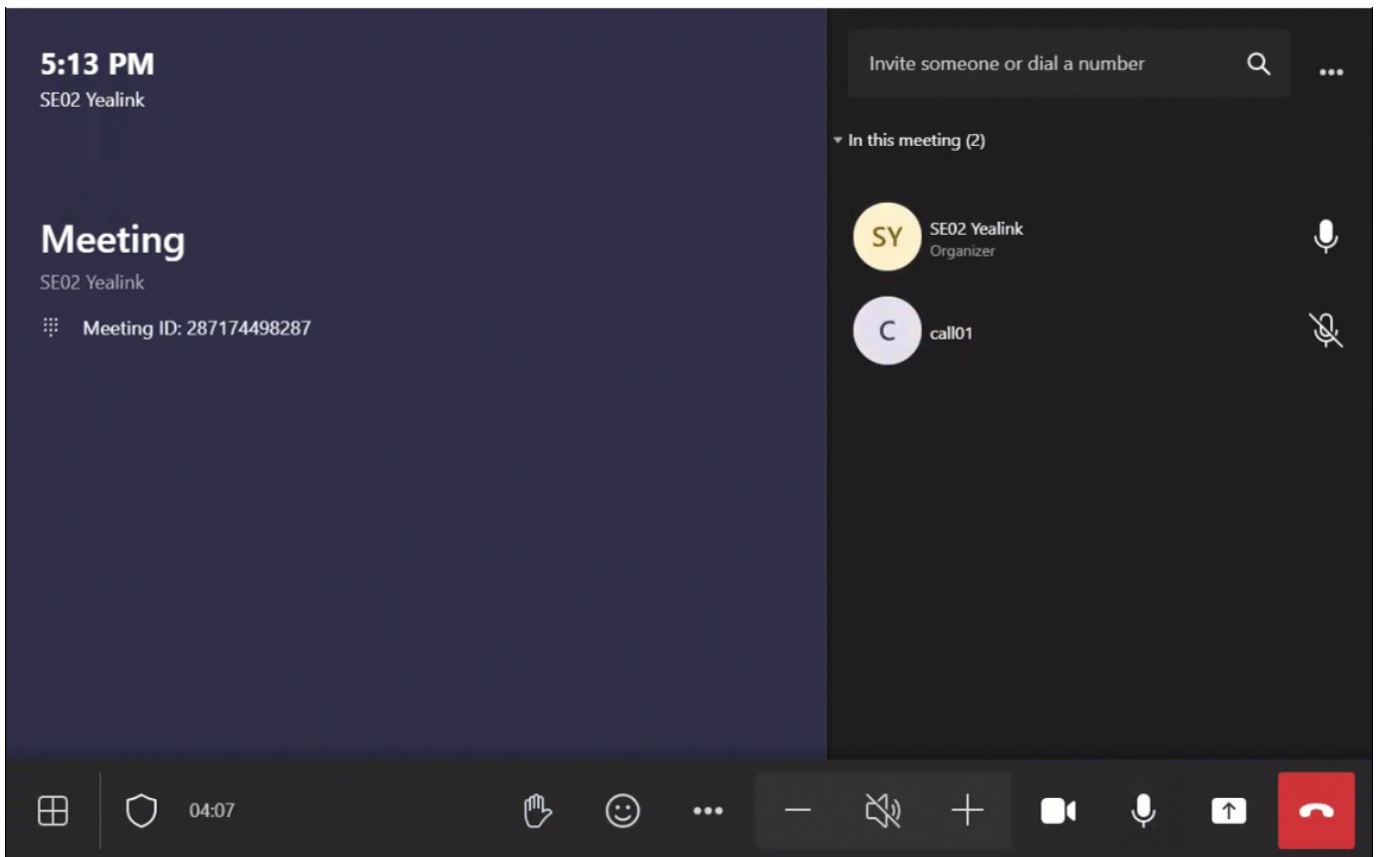

Effect Demonstration

[Speaker Tracking](#)

FAQ

After enabling Conversation Mode, the camera does not frame the two speakers.

There may be the following:

- When one of the two members in the conversation stops talking and the other continues to speak for a while, the camera will exit the Conversation Mode and only frame the speaking member.
- When the third member starts speaking during a conversation between two members, the camera will also exit the Conversation Mode after a while.

How to disable Speaker Tracking?

You can disable the Speaker Tracking and choose another mode of Tracking Mode: Auto Framing or Presenter Tracking.

You can also disable the Tracking Mode to control the camera manually. For more information, please refer to [Manual Control](01. Manual Controls.md).

Presenter Tracking

Introduction

The Presenter Tracking can automatically follow and zoom in/out a moving presenter to keep the presenter in the center of the screen. You can choose different tracking modes according to different scenarios:

- **Wide Area Tracking:** Track your target everywhere with Wide Area Tracking. This feature allow presenters to leave the stage and interact with a crowd or students, all while being continuously tracked even if obscured by other people or objects.
- **Segment Tracking:** Segment Tracking enhances your ability to capture content on multiple displays. Create up to 4 Content Zones to perfectly capture the content on display rather than the presenter. Suitable for scenarios with multiple screens (projection, whiteboard, blackboard, etc.), the camera will automatically switch to the camera preset of the corresponding screen area to better present the corresponding screen content.
- **Stage Tracking:** Get high-quality, hands-free video streaming and recording with Stage Tracking. Suitable for lecture theater or stage scenarios. The camera will start tracking when a presenter moves in the effective area.

For the operation video, please refer to [Presenter Tracking](#)

NOTE

If another presenter enters the tracking area during tracking, the camera will not switch the tracking target. Suppose you want to switch the tracked presenter; you need to wait for the original presenter to leave the camera's tracking area until the camera stops tracking. Then the camera will follow the new presenter. It is only applicable to UVC86 (Firmware Version: 151.410.0.5 or later).

How to Use

You can directly use the MTouch II matched with MVC to operate or log in to the Yealink Device Management Platform to operate remotely. For the remote control, please refer to [Remote Control](#).

Wide Area Tracking

1. Lens Calibration

NOTE

Lens calibration is required before using the presenter tracking mode. When you calibrate the lens, please ensure that there are no other things within 3 meters in front of the lens. Otherwise, it will be prompted that Lens calibration failed, please try to recalibrate.

You need to switch the system to Windows Mode (For more information, please refer to [Switch Account](#)).

1. Open the Yealink RoomConnect application and select the camera card.
2. Select **Device Settings**.
3. Select **Lens Calibration**.

Y Yealink RoomConnect ⚙️ | — | ✕

← Return

UVC86

- ☰ Device Status
- 🔧 Device Settings**
- 📺 Image Setting
- 🏠 Update Device
- 🛠️ Device Support
- 🔊 Audio Settings

⬆️ | 🔍 | 🔍 | ⬆️ | ⬅️ | ⬇️ | ➡️ | 🔄 Reset

- General Settings >
- Advanced Settings >
- Lens Calibration** ⊕
- Tracking Feature
- PIP Mode
- Presets
- +
New Preset

2. Enable Presenter Mode

1. Enable **Tracking Feature**.
2. Select **Presenter Tracking** in **Tracking Mode**.

Y Yealink RoomConnect ⚙️ | — | ✕

← Return

UVC86

- ☰ Device Status
- 🔧 Device Settings**
- 📺 Image Setting
- 🏠 Update Device
- 🛠️ Device Support
- 🔊 Audio Settings

⬆️ | 🔍 | 🔍 | ⬆️ | ⬅️ | ⬇️ | ➡️ | 🔄 Reset

- General Settings >
- Advanced Settings >
- Lens Calibration ⊕
- Tracking Feature**
- Tracking Mode Auto Framing ^
- Tracking Spe
 - Auto Framing ✔️
 - Speaker Tracking
 - Presenter Tracking**
 - Multi Focus

3. Set Wide Area Tracking

Track your target everywhere with Wide Area Tracking. This feature allow presenters to leave the stage and interact with a crowd or students all while being continuously tracked even if obscured by other people or objects.

1. Select **Wide Area Tracking** in **Mode Selection**.

Y Yealink RoomConnect

← Return

UVC86

- Device Status
- Device Settings**
- Image Setting
- Update Device
- Device Support
- Audio Settings

General Settings >

Advanced Settings >

Tracking Mode Presenter Tracking ▾

Mode Selection Wide Area Tracking ▲

Trigger Mode Wide Area Tracking ✓

Object Viewing Dimension Segment Tracking

Time Out Stage Tracking

Sensitivity 3

PIP Mode

2. Select **Priority Zone Trigger/Gesture Trigger** in **Trigger Mode**.

Priority Zone Trigger: Custom setting effective tracking area. When the camera selects the presenter successfully, the LED indicator flashes red and green three times. If many people appear in the priority zone, the camera randomly chooses one of them as the presenter.

Gesture Trigger: When raising your hand and facing the camera for over 2 seconds. The camera will recognize you as the presenter until the LED indicator flashes three times. Facing the camera, raise your fist and hold it for more than 2 seconds to stop tracking.

Y Yealink RoomConnect

← Return

UVC86

- Device Status
- Device Settings**
- Image Setting
- Update Device
- Device Support
- Audio Settings

General Settings >

Advanced Settings >

Tracking Mode Presenter Tracking ▾

Mode Selection Wide Area Tracking ▾

Trigger Mode Priority Zone ▾

Tracking Trigger Zone >

Object Viewing Dimension >

Time Out 5

Sensitivity 3

3. Select **Tracking Trigger Zone**.

In the effective area, drag and select the area that wants to be tracked (a green frame will show on the screen).

3. Select **Save**.

NOTE

When the tracking mode is Wide Area Tracking, and the trigger mode is Gesture Trigger, you do not need to set the Tracking Trigger Area.

4. Select **Object Viewing Dimension** to adjust the camera's angle and focal length of the camera.

5. Customize other tracking settings:

Setting Timeout: When the camera does not detect the presenter within the limited time, it goes to the initial position and captures the next moving presenter. If the camera does not find a presenter in the tracking area, it waits for the next moving presenter. (Range: 5s - 30s, default: 5s)

Setting Sensitivity: When you move fast (such as walking back and forth), the camera can react quickly. (Range: 1 - 5, default: 3)

PIP Mode (Picture in Picture): UVC86 supports panoramas and close-up views in PIP mode, allowing you to see all participants simultaneously and focus on the speaker. For more information, please refer to [PIP Mode](#).

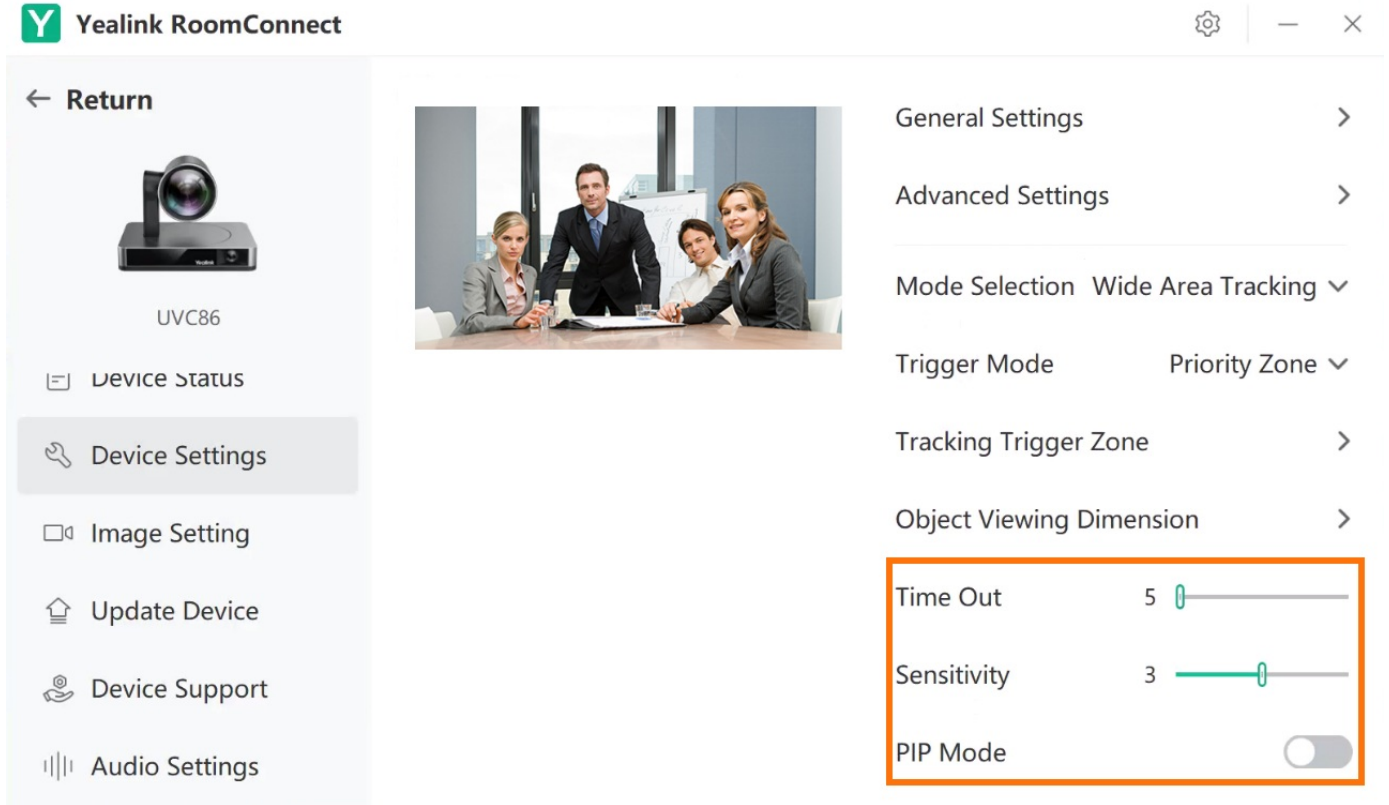

Segment Tracking

1. Lens Calibration

NOTE

Lens calibration is required before using the presenter tracking mode. Otherwise, it will be prompted that Lens calibration failed, please try to recalibrate.

You need to switch the system to Windows Mode (For more information, please refer to [Switch Account](#)).

1. Open the Yealink RoomConnect application and select the camera card.
2. Select **Device Settings**.
3. Select **Lens Calibration**.

The screenshot shows the Yealink RoomConnect web interface. On the left, a sidebar menu contains several options: 'Return', 'Device Status', 'Device Settings' (highlighted with an orange border), 'Image Setting', 'Update Device', 'Device Support', and 'Audio Settings'. The main content area features a camera icon labeled 'UVC86', a live video feed of a meeting, and a control panel with navigation arrows and a 'Reset' button. On the right, a settings menu is visible, with 'Lens Calibration' highlighted in orange.

2. Enable Presenter Mode

1. Enable **Tracking Feature**.
2. Select **Presenter Tracking** in **Tracking Mode**.

This screenshot shows the same Yealink RoomConnect interface as above, but with the 'Tracking Feature' toggle switch turned on and highlighted in orange (marked with a '1'). Below it, the 'Tracking Mode' dropdown menu is open, showing 'Presenter Tracking' selected and highlighted in orange (marked with a '2'). A third orange circle (marked with a '3') points to the 'Presenter Tracking' option in the dropdown list. The 'Device Settings' menu item in the sidebar remains highlighted.

3. Segment Tracking

Segment Tracking enhances your ability to capture content on multiple displays. Create up to 4 Content Zones to perfectly capture the content on display rather than the presenter. Suitable for scenarios with multiple screens projection, whiteboard, blackboard, etc.), the camera will automatically switch to the camera preset of the corresponding screen area to better present the corresponding screen content.

1. Select **Segment Tracking** in **Mode Selection**.

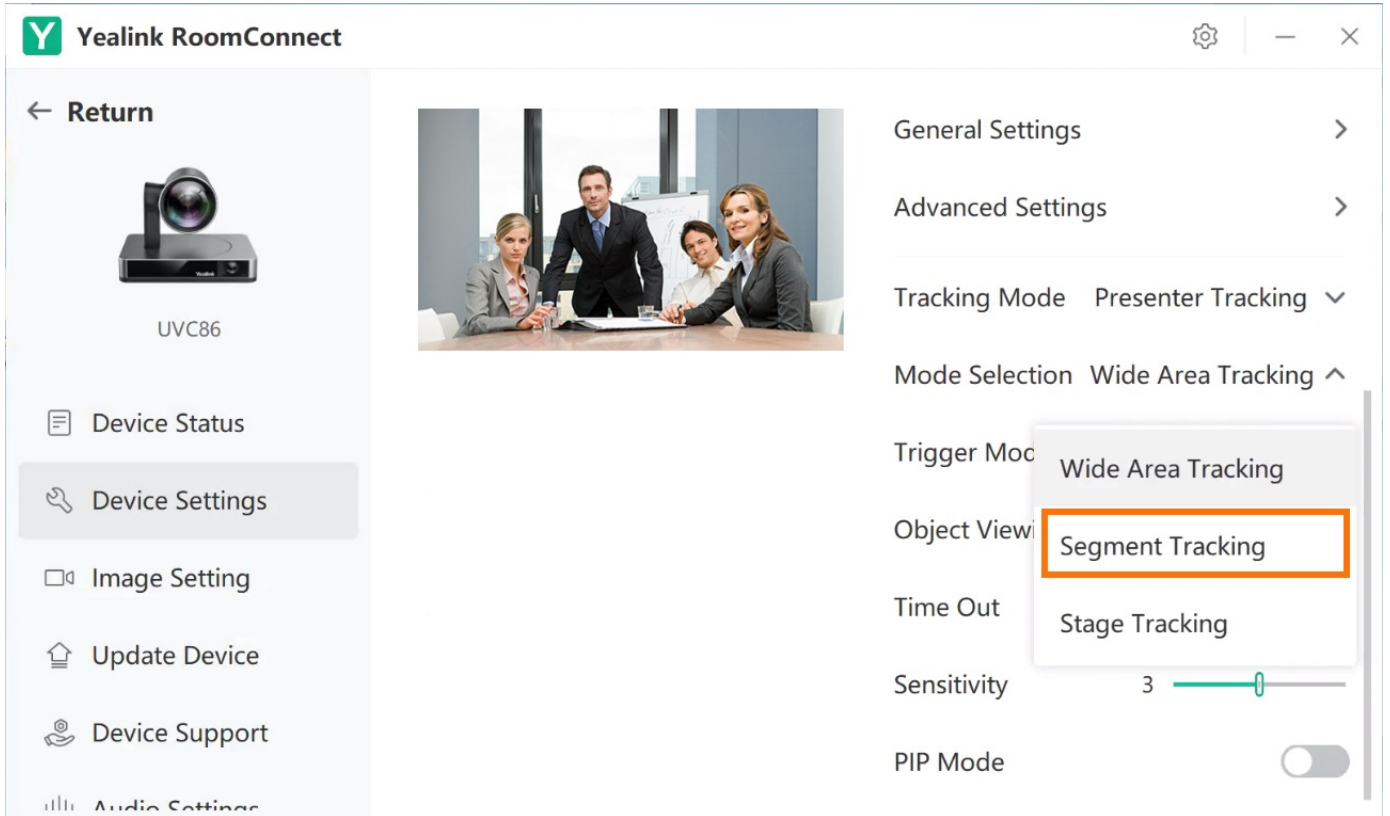

2. Select **Priority Zone Trigger/Gesture Trigger** in **Trigger Mode**.

Priority Zone Trigger: Custom setting effective tracking area. When the camera selects the presenter successfully, the LED indicator flashes red and green three times. When the camera selects the presenter successfully, the camera indicator flashes red and green three times.

Gesture Trigger: When raising your hand and facing the camera for over 2 seconds, the camera will recognize you as the presenter. Facing the camera, raise your fist and hold it for more than 2 seconds to stop tracking.

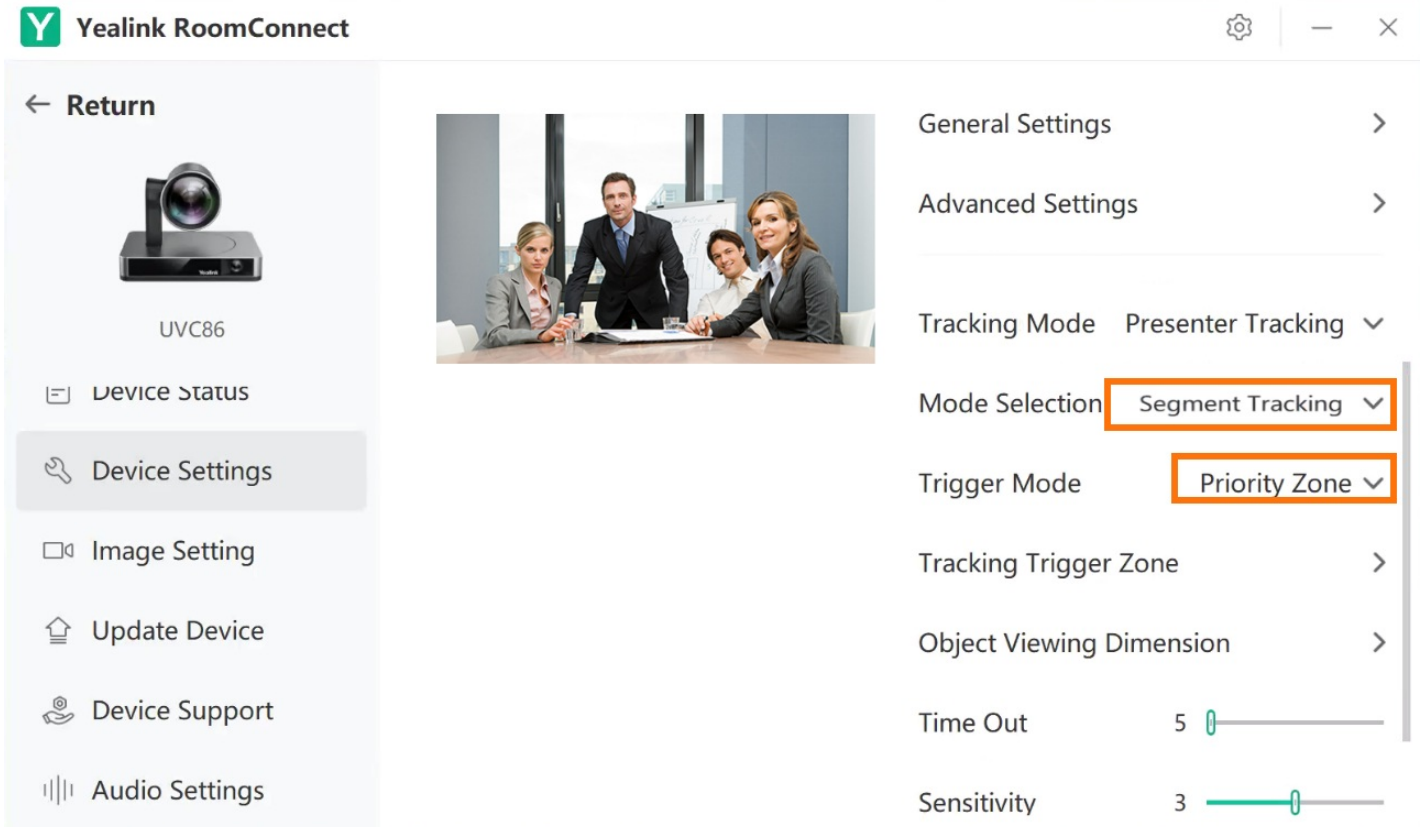

3. Select **Effective Tracking Zone**.

In the effective area, drag and select the area that wants to be tracked (a green frame will show on the screen).

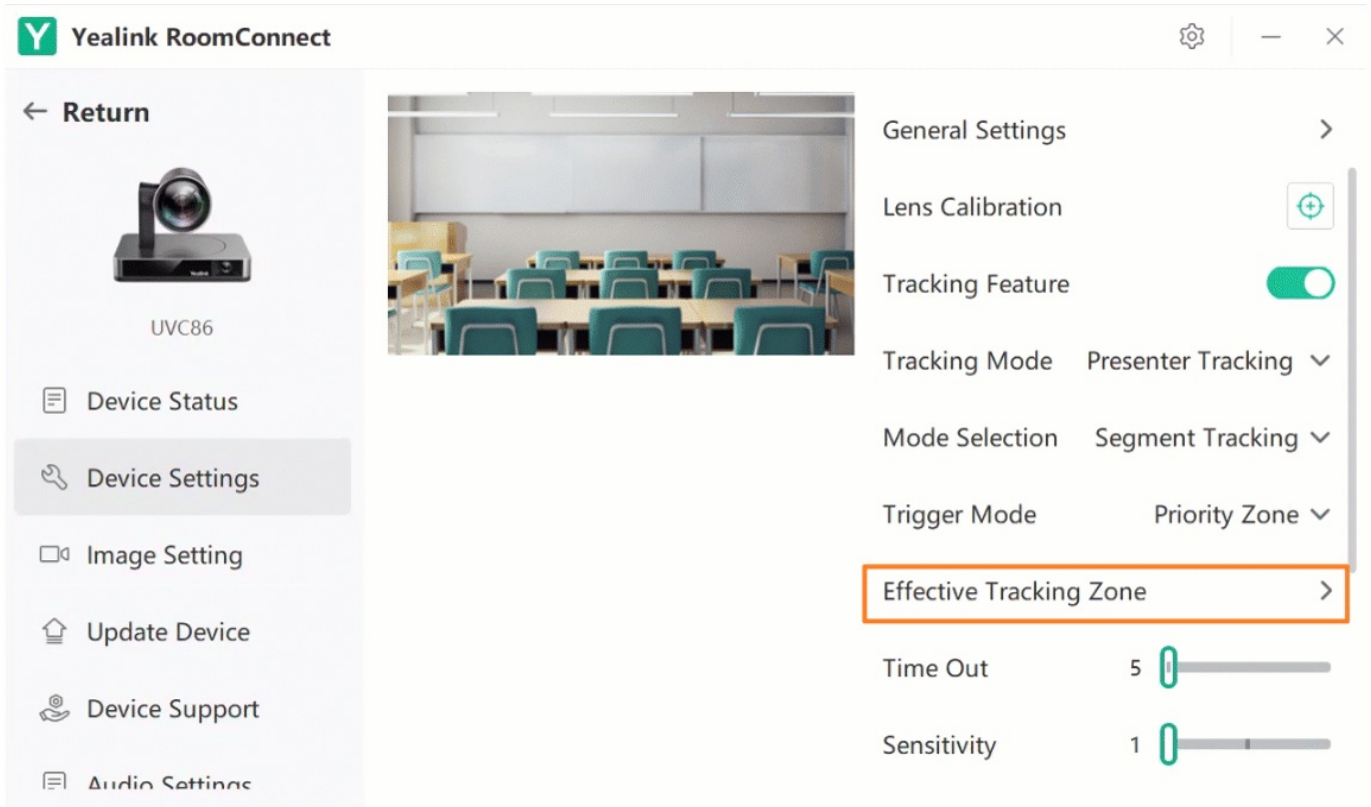

4. You can set **Number of segments** from 1 to 4 and change the size of each segment by dragging with your finger or mouse.

NOTE
We recommend you make an overlap between segments to avoid the camera frequently moving at the junction point.

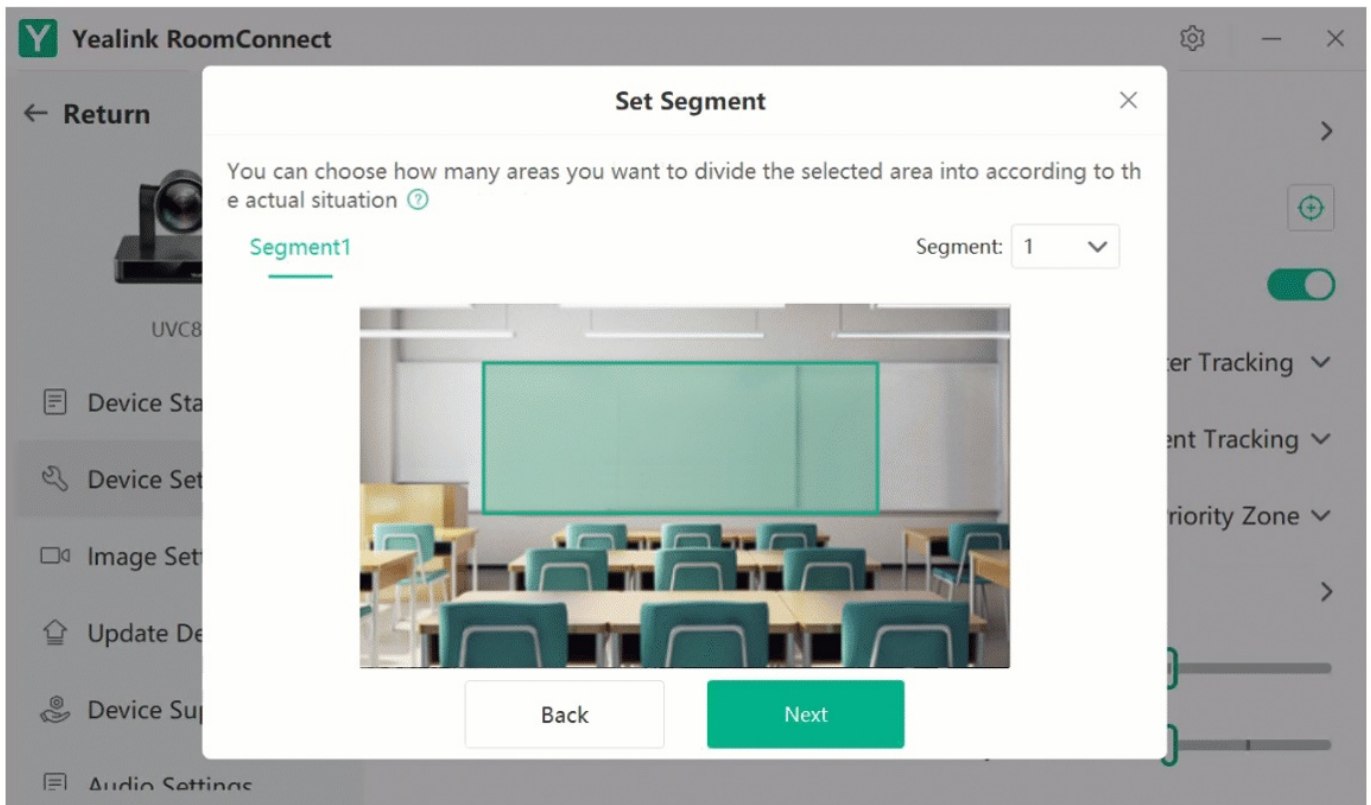

5. You can do the following to set the camera preset for each segmented area.

Select **Finish**.

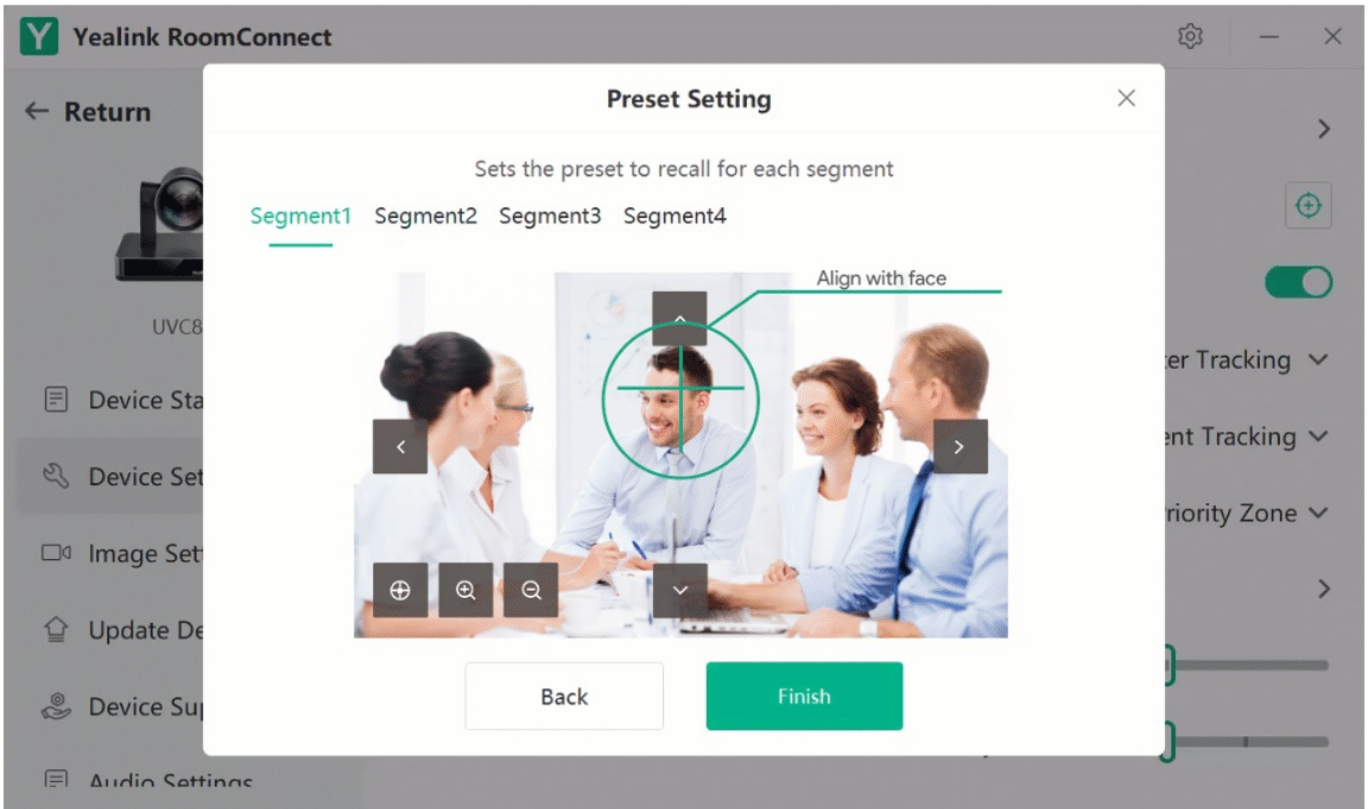

6. Select **Tracking Object Ratio** to adjust the angle and focal length of the camera.

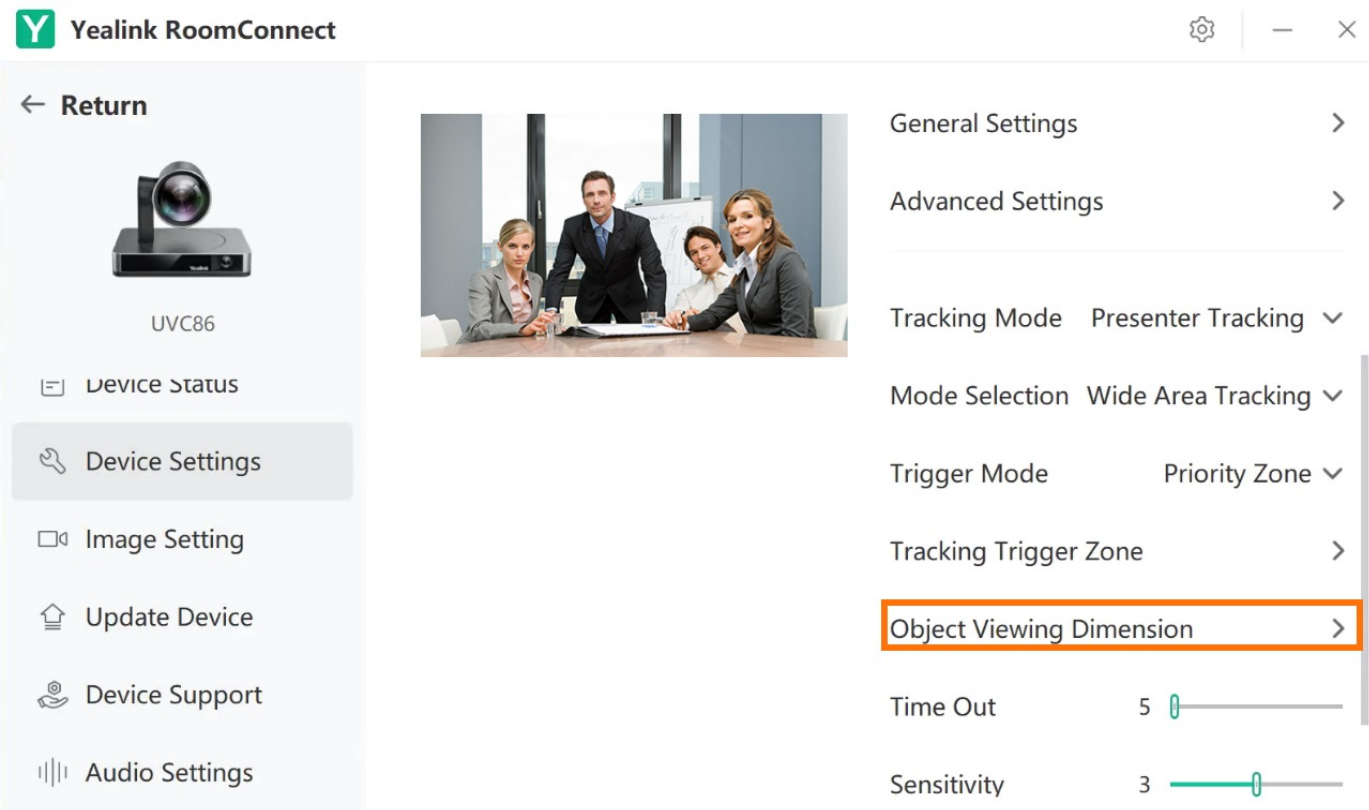

7. Customize other tracking settings:

Setting Timeout: When the camera does not detect the presenter within the limited time, it goes to the initial position and captures the next moving presenter. If the camera does not find a presenter in the zone, it waits for the next moving presenter. (Range: 5s - 30s, default: 5s)

Setting Sensitivity: When you move fast (such as walking back and forth), the camera can react quickly. (Range: 1 - 5, default: 3)

PIP Mode (Picture in Picture): UVC86 supports panoramas and close-up views in PIP mode, allowing you to see all participants simultaneously and focus on the speaker. For more information, please refer to [PIP Mode](#).

Stage Tracking

1. Lens Calibration

NOTE

Lens calibration is required before using the presenter tracking mode. Otherwise, it will be prompted that Lens calibration failed, please try to recalibrate.

You need to switch the system to Microsoft Teams mode (For more information, please refer to [Switch Account](#)).

1. Open the Yealink RoomConnect application and select the camera card.
2. Select **Device Settings**.

3. Select **Lens Calibration**.

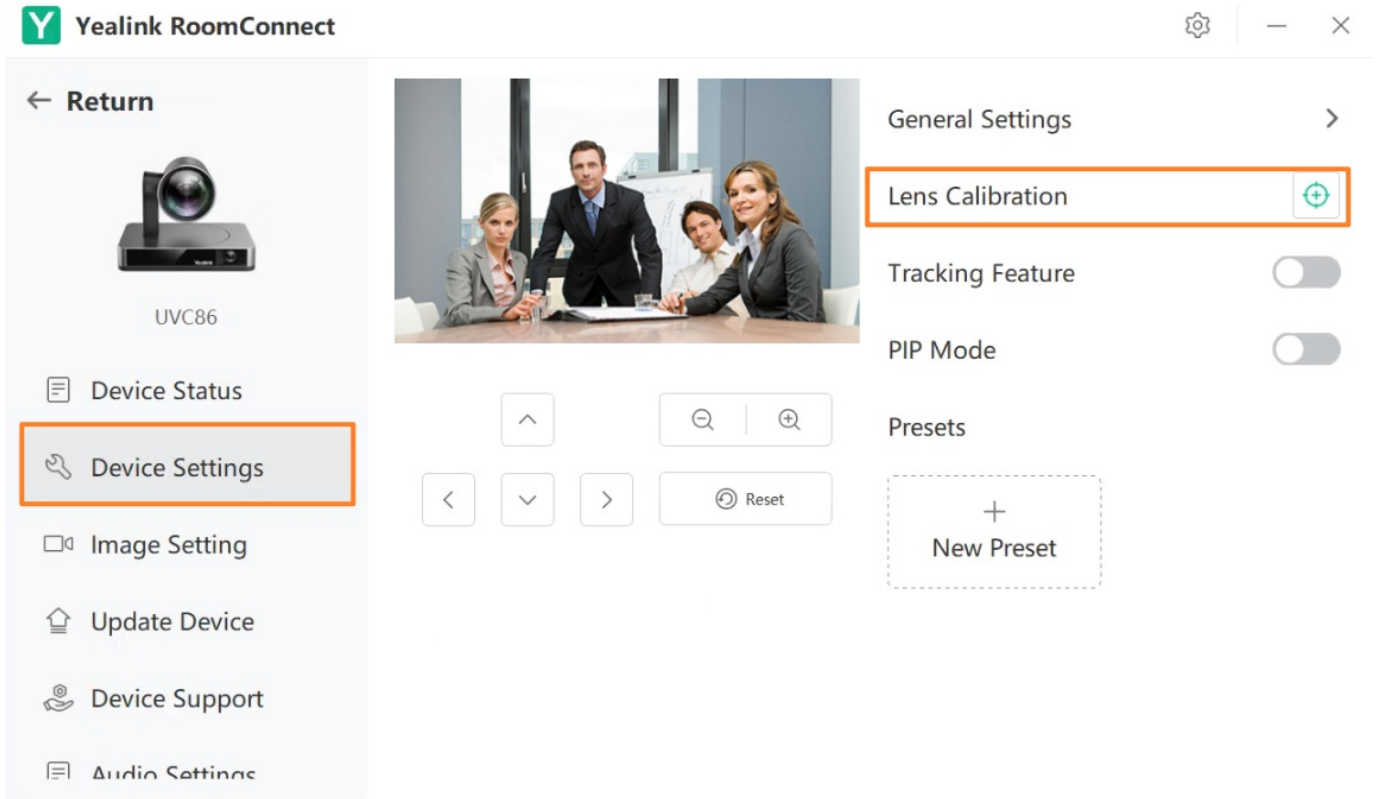

2. **Enable Presenter Mode**

1. Enable **Tracking Feature**.
2. Select **Presenter Tracking** in **Tracking Mode**.

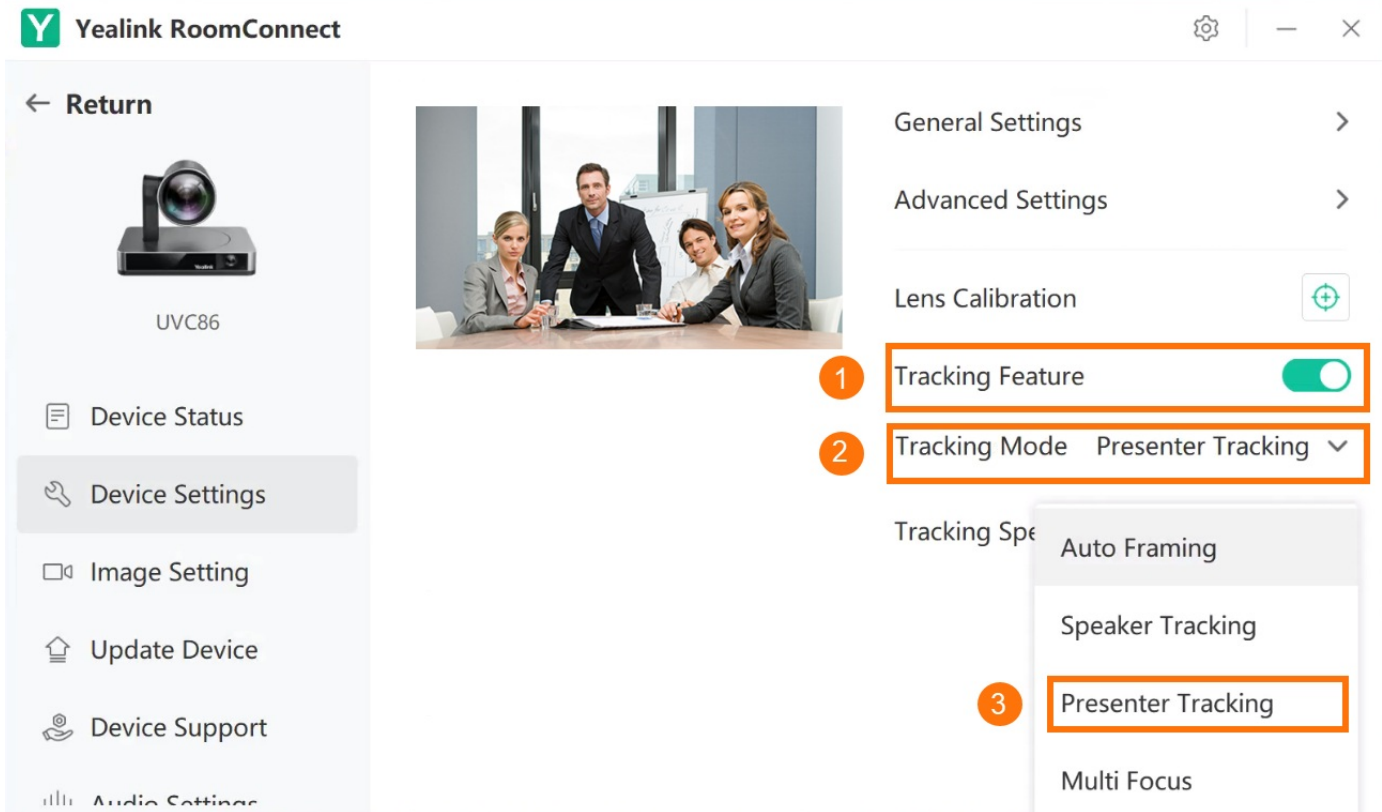

3. **Segment Stage Tracking**

Stage Tracking: Get high-quality hands-free video streaming and recording with Stage Tracking. Suitable for lecture theater or stage scenarios. The camera will start tracking when a presenter moves in the effective area.

1. Select **Stage Tracking** in **Mode Selection**.

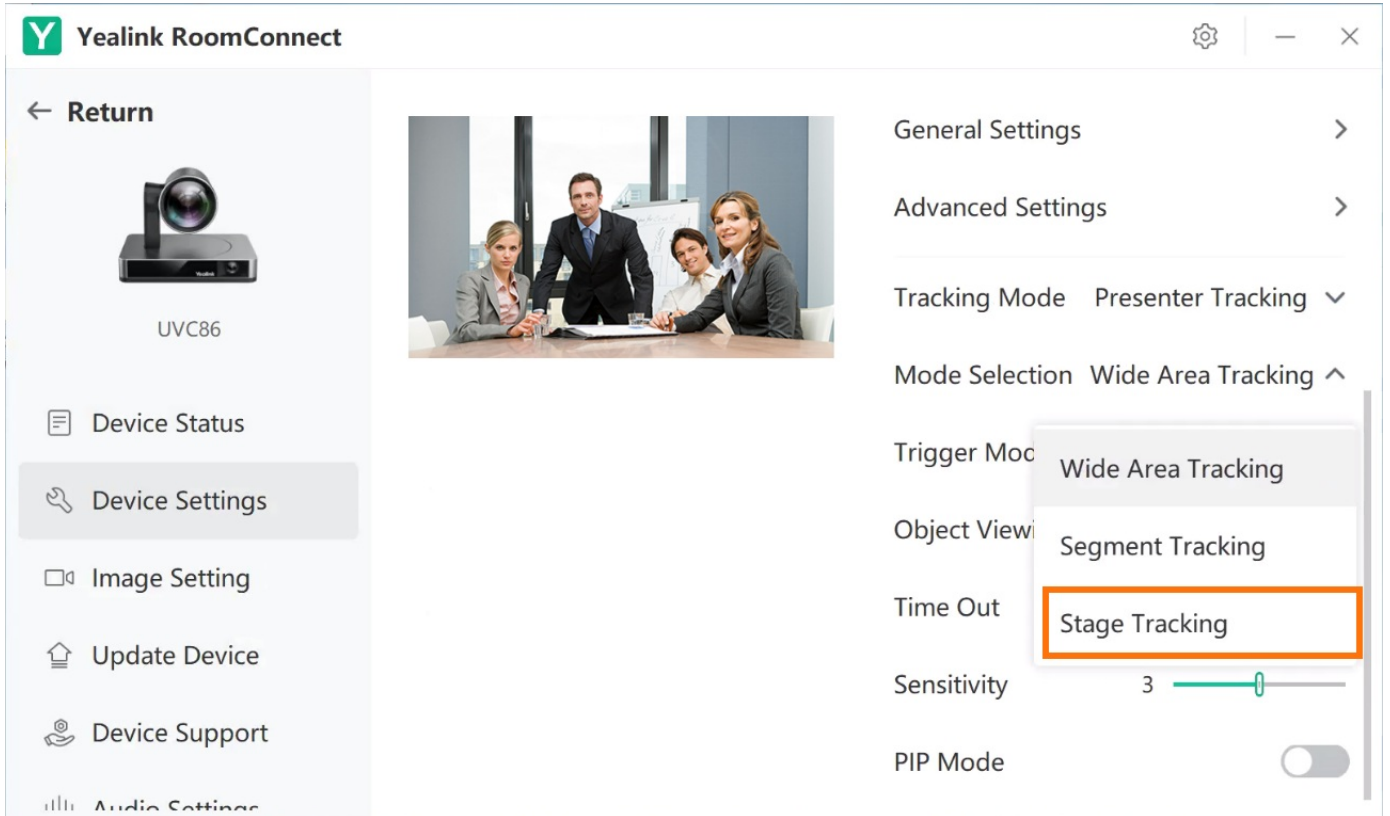

2. Select **Priority Zone Trigger/Gesture Trigger** in **Trigger Mode**.

Priority Zone Trigger: You can use your finger or a mouse to select the priority zone on the screen. When many people appear in the priority zone, the camera randomly chooses one of them as the presenter. When the camera selects the presenter successfully, the camera indicator flashes red and green three times.

Gesture Trigger: When raising your hand and facing the camera for over 2 seconds, the camera will recognize you as the presenter. Facing the camera, raise your fist and hold it for more than 2 seconds to stop tracking.

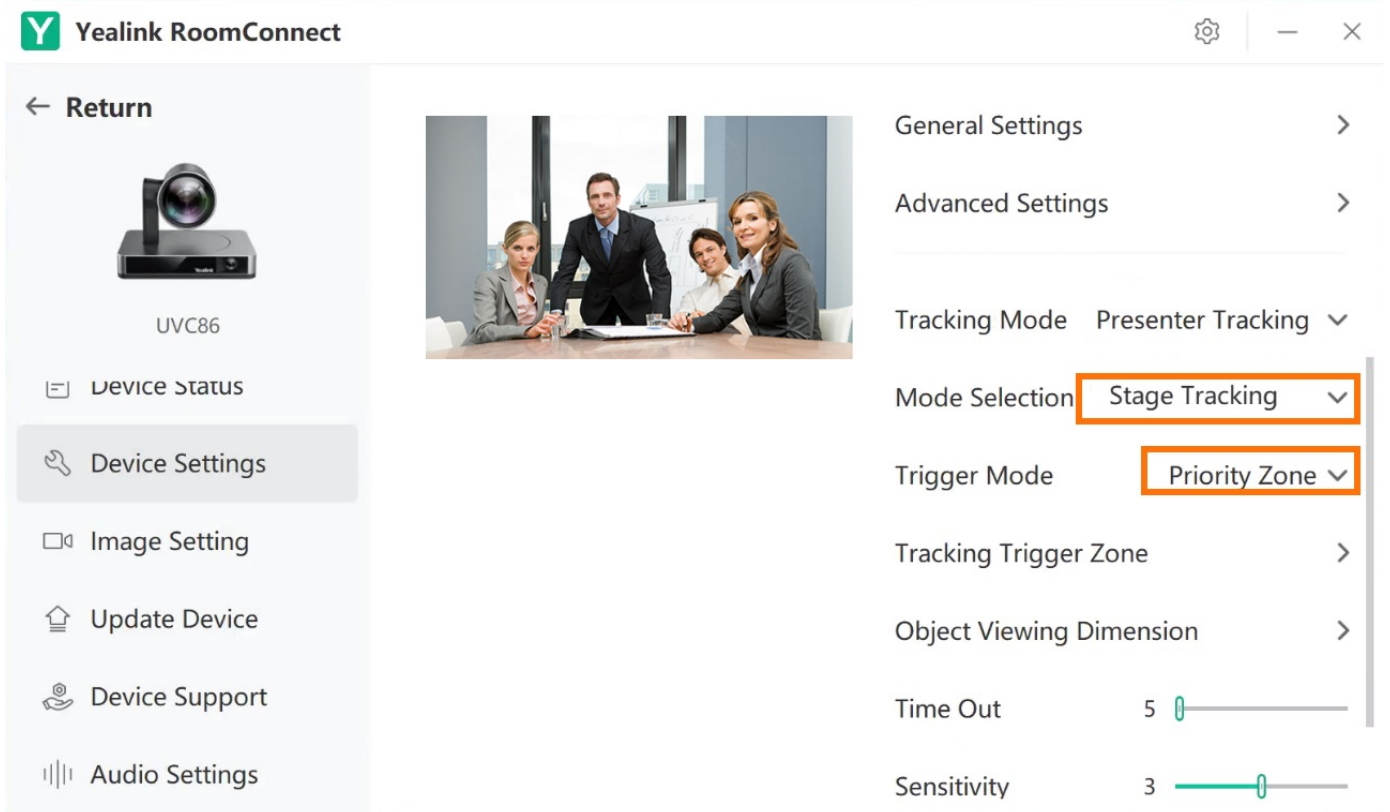

3. Select **Tracking Trigger Area**.

In the effective area, drag and select the area that wants to be tracked (a green frame will show on the screen).

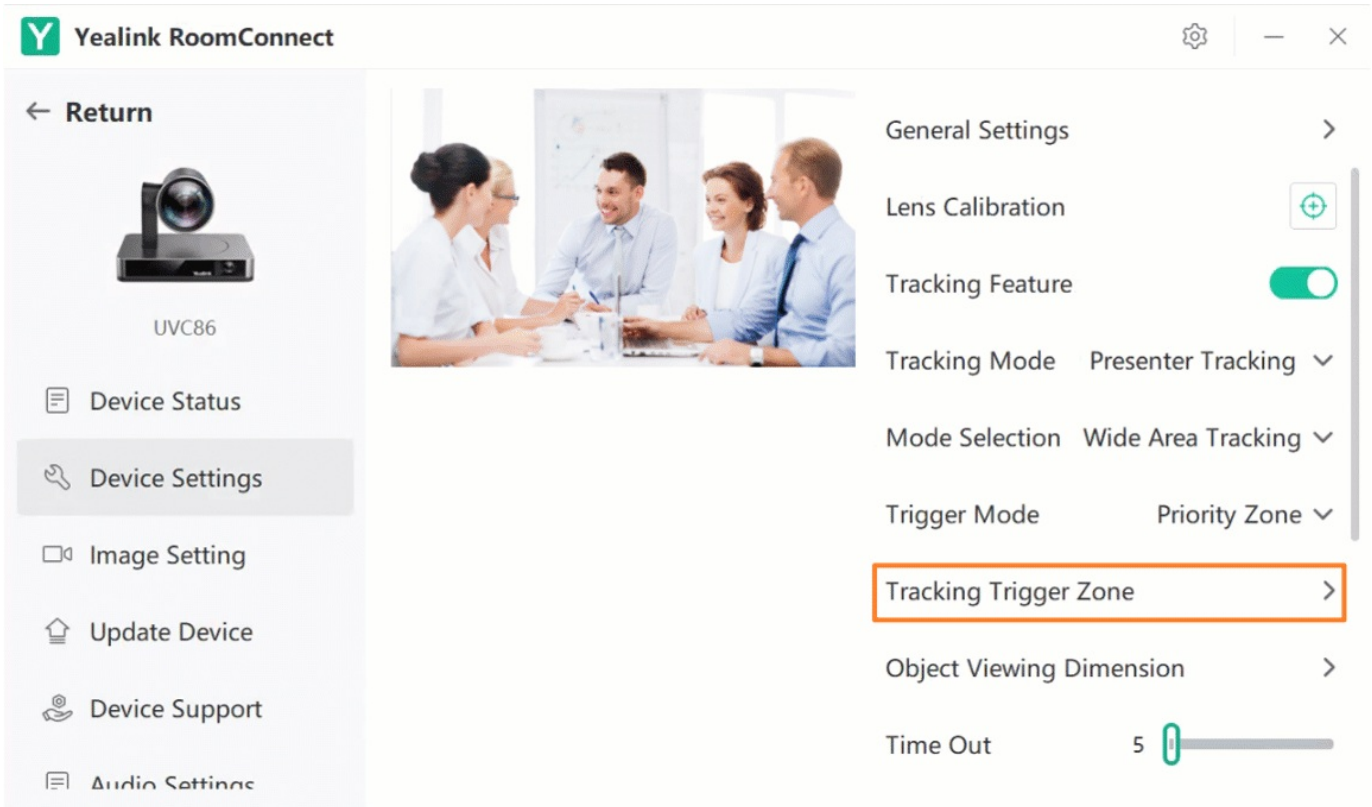

4. Select **Object Viewing Dimension** to adjust the direction and focal length of the camera.

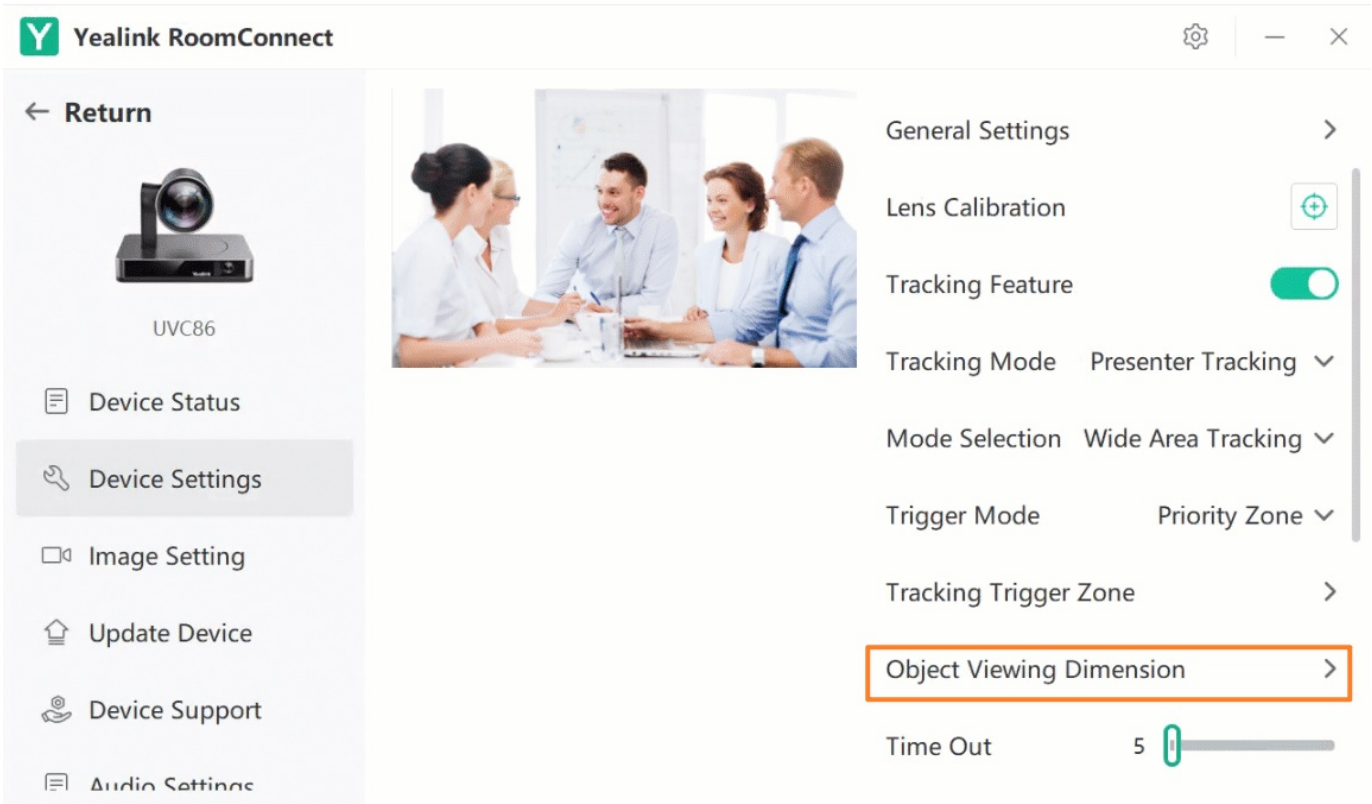

5. Customize other tracking settings:

Setting Timeout: When the camera does not detect the presenter within the limited time, it goes to the initial position and captures the next moving presenter. If the camera does not find a presenter in the zone, it waits for the next moving presenter. (Range: 5s - 30s, default: 5s)

Setting Sensitivity: When you move fast (such as walking back and forth), the camera can react quickly. (Range: 1 - 5, default: 3)

PIP Mode (Picture in Picture): UVC86 supports panoramas and close-up views in PIP mode, allowing you to see all participants simultaneously and focus on the speaker. For more information, please refer to [PIP Mode](#).

Switch Presenter Tracking in Microsoft Teams Rooms

After you set the tracking mode to speaker tracking in the Yealink RoomConnect application, the camera will operate in the speaker mode by default in the Microsoft Teams Rooms meeting. But you cannot manually control the camera at this time. If you want to change the tracking mode of the Microsoft Teams Rooms meeting, you can switch to other tracking modes  in the upper-right corner.

You need to switch the system to Microsoft Teams mode (For more information, please refer to [Switch Account](#)).

When you are not in a meeting:

1. Select **Room Controls** to enter **Camera Control**.
2. Select other tracking modes.

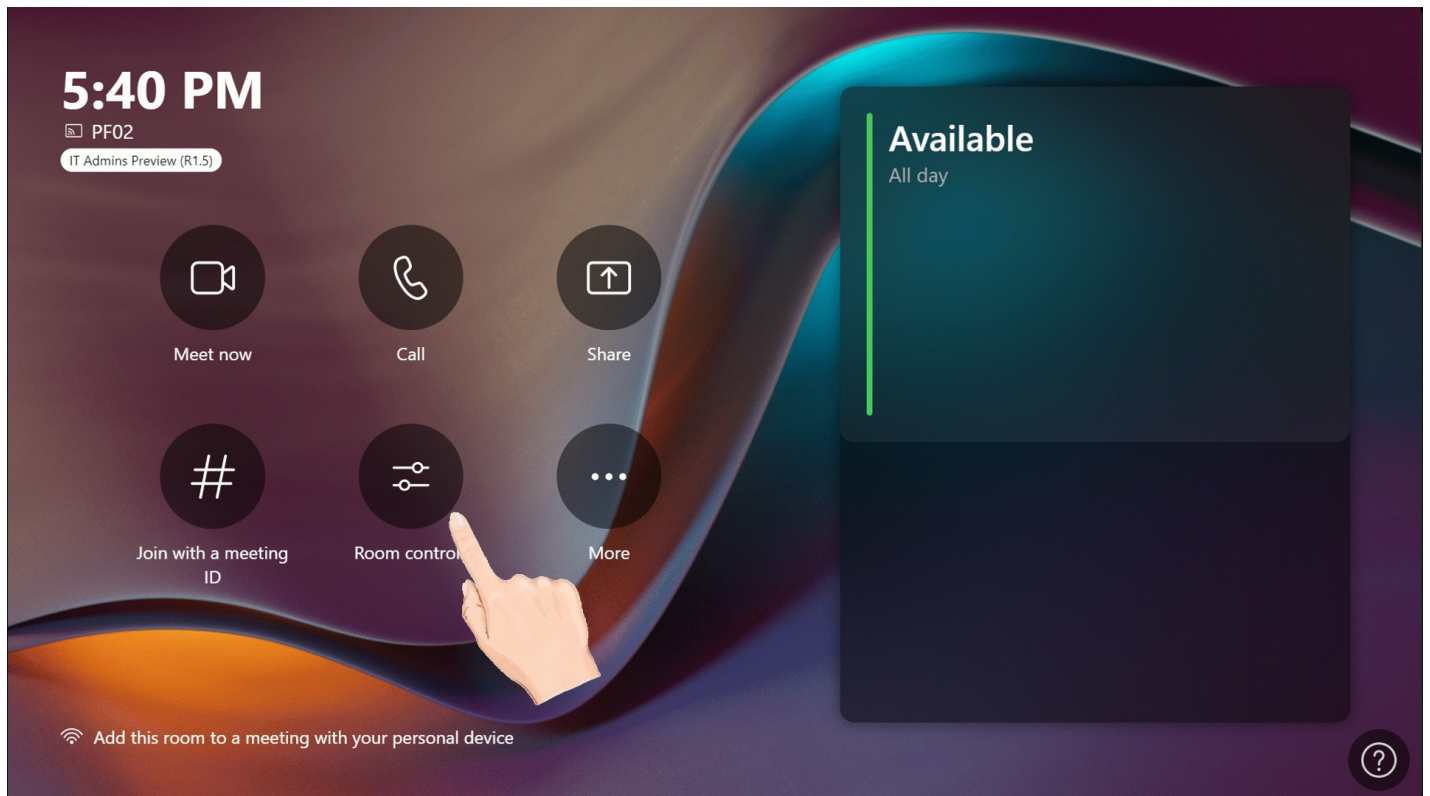

When you are in a meeting:

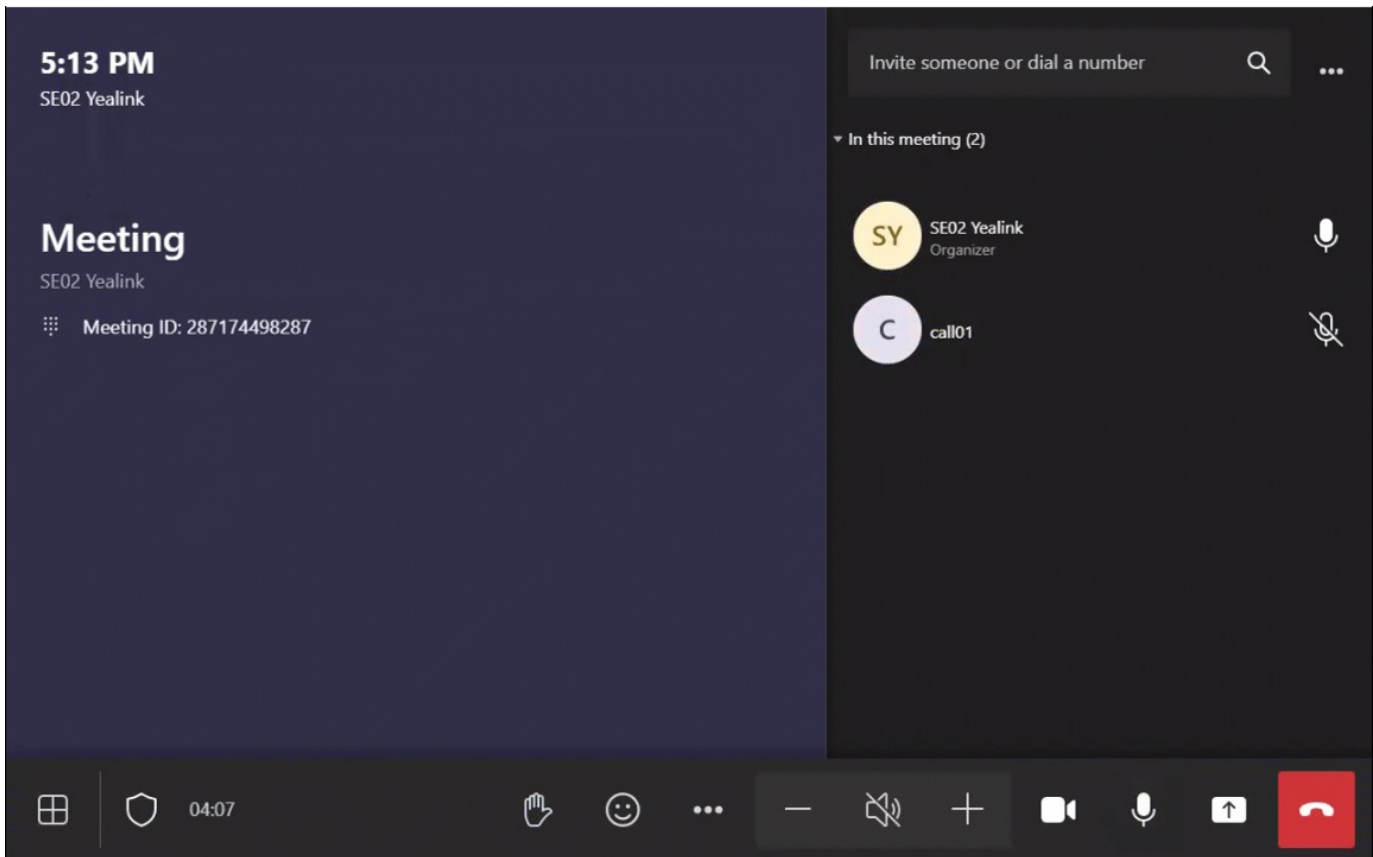

FAQ



What if the lens calibration fails?

When the lens calibration fails, check whether there are other things within 3 meters in front of the lens, and recalibrate after removing.

The tracking mode can not be triggered.

When the tracking fails to take effect, check whether the person has entered the set effective tracking area and appropriately expand the setting of the tracking range. If it is a Segment Tracking mode, we recommend you make an overlap between segments to avoid the camera frequently moving at the junction point.

When I adjust the camera, you can not center participants on the screen center.

Go to **Device Settings > General Setting > Camera Pan Direction** to check whether the setting is **Normal** or **Reversed**. If the setting is **Normal**, select  to adjust when the participant is to the right. If the setting is **Reversed**, select  to adjust when the participant is to the right.

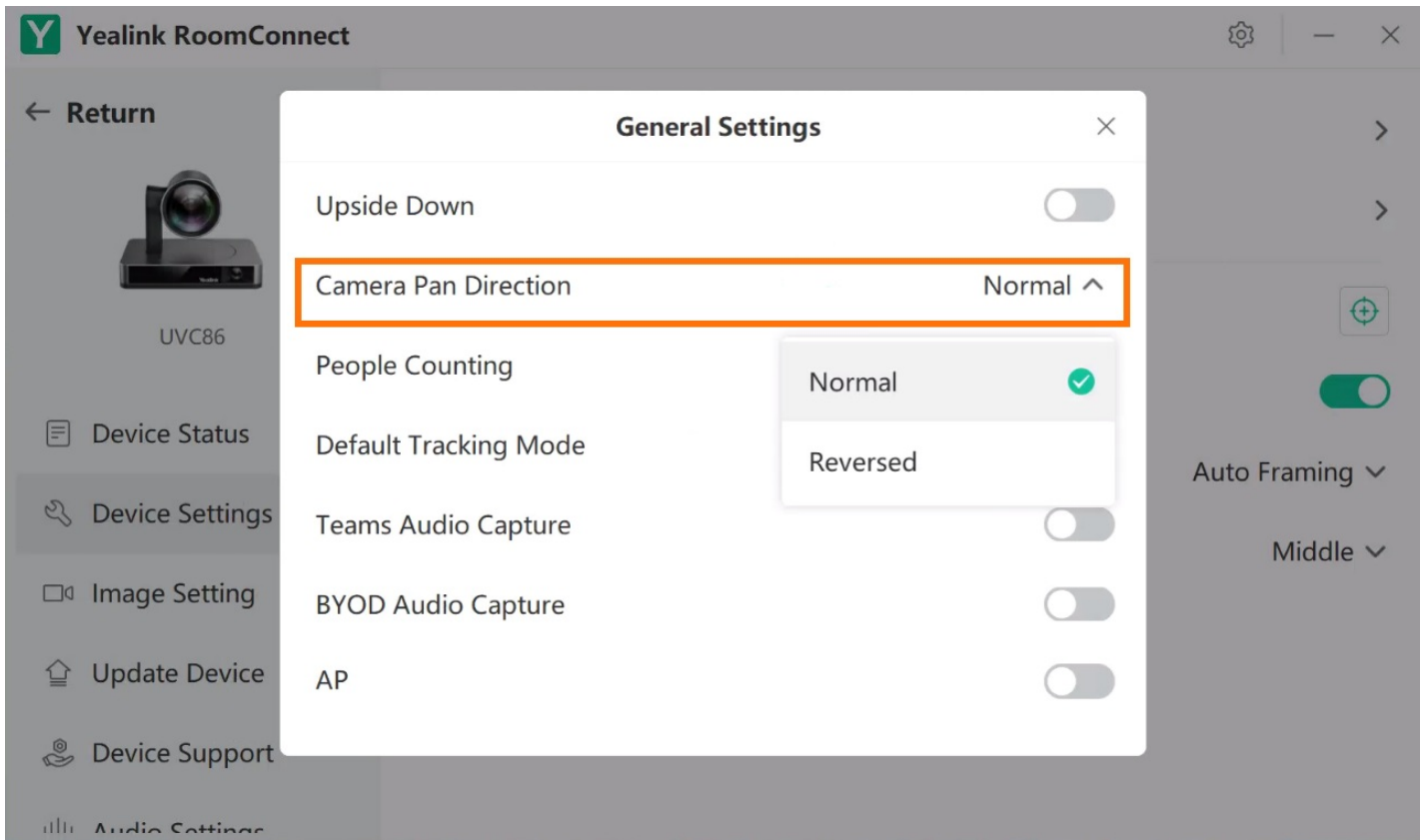

Does the camera automatically switch presenter tracking?

If another presenter enters the tracking area during tracking, the camera will not switch the tracking target. Suppose you want to switch the tracked presenter; you need to wait for the original presenter to leave the camera's tracking area until the camera stops tracking. Then the camera will follow the new presenter.

Multi Focus

Introduction

NOTE

Only the UVC86 (version 151.431.0.5 and later) supports Multi Focus mode.

The UVC86 supports Multi Focus mode, making meeting communication more efficient. For multi-person meetings, a separate close-up of each participant is cropped so that more participants appear on the screen and fully discuss with the other party, making the meeting more realistic. When several participants are close together, they will be merged into the multi-focus framing, as shown below.



This feature is applicable to horizontal meeting rooms and supports up to six split-screen images. When the split-screen image is more than six, the meeting image will switch to Auto Framing to display all participants.

To create a perfect video meeting experience, the distance between participants should be at least 30 cm.

How to Use

You can directly use the MTouch II matched with MVC to operate or log in to the Yealink Device Management Platform to operate remotely. For the remote control, please refer to [Remote Control](#).

1. You need to switch the system to Windows Mode (For more information, please refer to [Switch Account](#)).
2. Open the Yealink RoomConnect application and select the UVC86 camera card.
3. Select **Device Settings**.
4. Select **Multi Focus** in **Tracking Mode**.

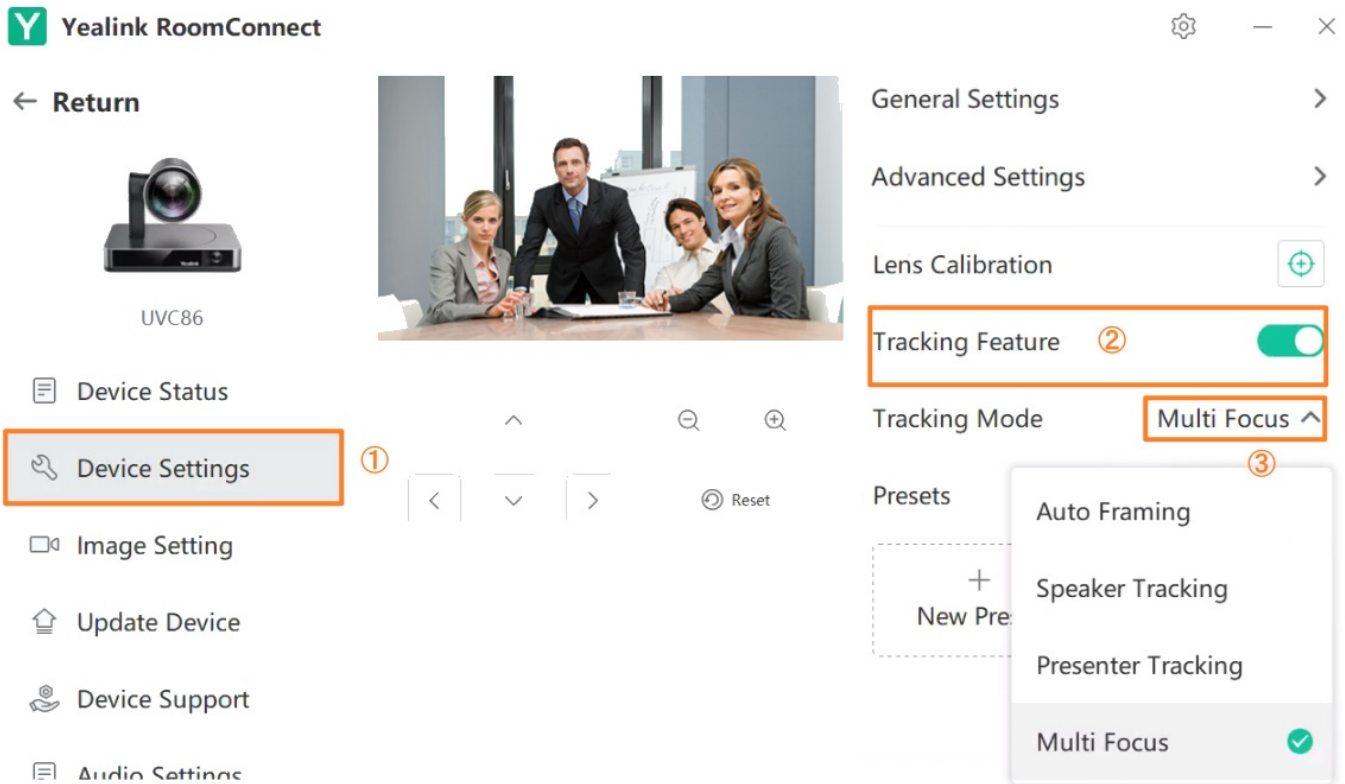

PIP Mode

Introduction

The PIP (Picture in Picture) mode supports panoramic and close-up views. It allows you to watch videos in a floating window so you can keep an eye on what you are watching.

NOTE

This feature is only applicable to UVC86 (firmware version: 151.424.0.5.rom or later).

How to Use

You can directly use the MTouch II matched with MVC to operate or log in to the Yealink Device Management Platform to operate remotely. For the remote control, please refer to [Remote Control](#).

1. Enable the PIP Mode

You need to switch the system to **Windows Mode** (For more information, please refer to [Switch Account](#)).

1. Open the Yealink RoomConnect application and select the camera card.
2. Select **Device Settings**.
3. Select **PIP Mode**.

NOTE

Please make sure you have disabled the Tracking Feature.

Yealink RoomConnect
⚙️ | — | ×

← Return



UVC86

- ☰ Device Status
- 🔧 Device Settings
- 📺 Image Setting
- 🏠 Update Device
- 🛎 Device Support
- 📶 Audio Settings



- General Settings >
- Advanced Settings >

- Conversation Mode
- PIP Mode
- Main Picture Close-up View ▾
- Thumbnail Position Bottom Right ▾
- Thumbnail Size 1/9 ▾
- Panoramic Camera Panoramic View ▾
- Transition

2. Set Main Picture and Panoramic Camera

When you disable Tracking Feature

1. You can enable the PIP mode when disabling the **Tracking Feature**.
2. After enabling it, you can set **Panoramic View** or **Auto Framing** as a default window of **Panoramic Camera** (a floating window).

Yealink RoomConnect
⚙️ | — | ×

← Return



UVC86

- ☰ Device Status
- 🔧 Device Settings
- 📺 Image Setting
- 🏠 Update Device
- 🛎 Device Support
- 📶 Audio Settings



^

🔍 | 🔍

<

v

>

↻ Reset

- General Settings >
- Lens Calibration +
- Tracking Feature
- PIP Mode
- Thumbnail Position Bottom Right ▾
- Thumbnail Size 1/9 ▾
- Panoramic Camera Panoramic View ▾
- Presets
- +

When you enable Tracking Feature

NOTE

You can set whether to enable the PIP mode in **Speaker Tracking** and **Presenter Tracking** when enabling the **Tracking Feature**.

After enabling it, you can set **Panoramic View** or **Auto Framing** as a default window of **Main Camera** (a small floating window).

You can also set **Panoramic View** or **Close-up View** as a default window of **Panoramic Camera** (it is the full-screen).

3. Set Thumbnail Position/Size

Go to **Thumbnail Position** to select **Top Left**, **Bottom Left** or **Bottom Right**.

Go to **Thumbnail Size** to set the floating window's size on the screen, which can be adjusted to **1/4** or **1/9** of the original screen (default: 1/9).

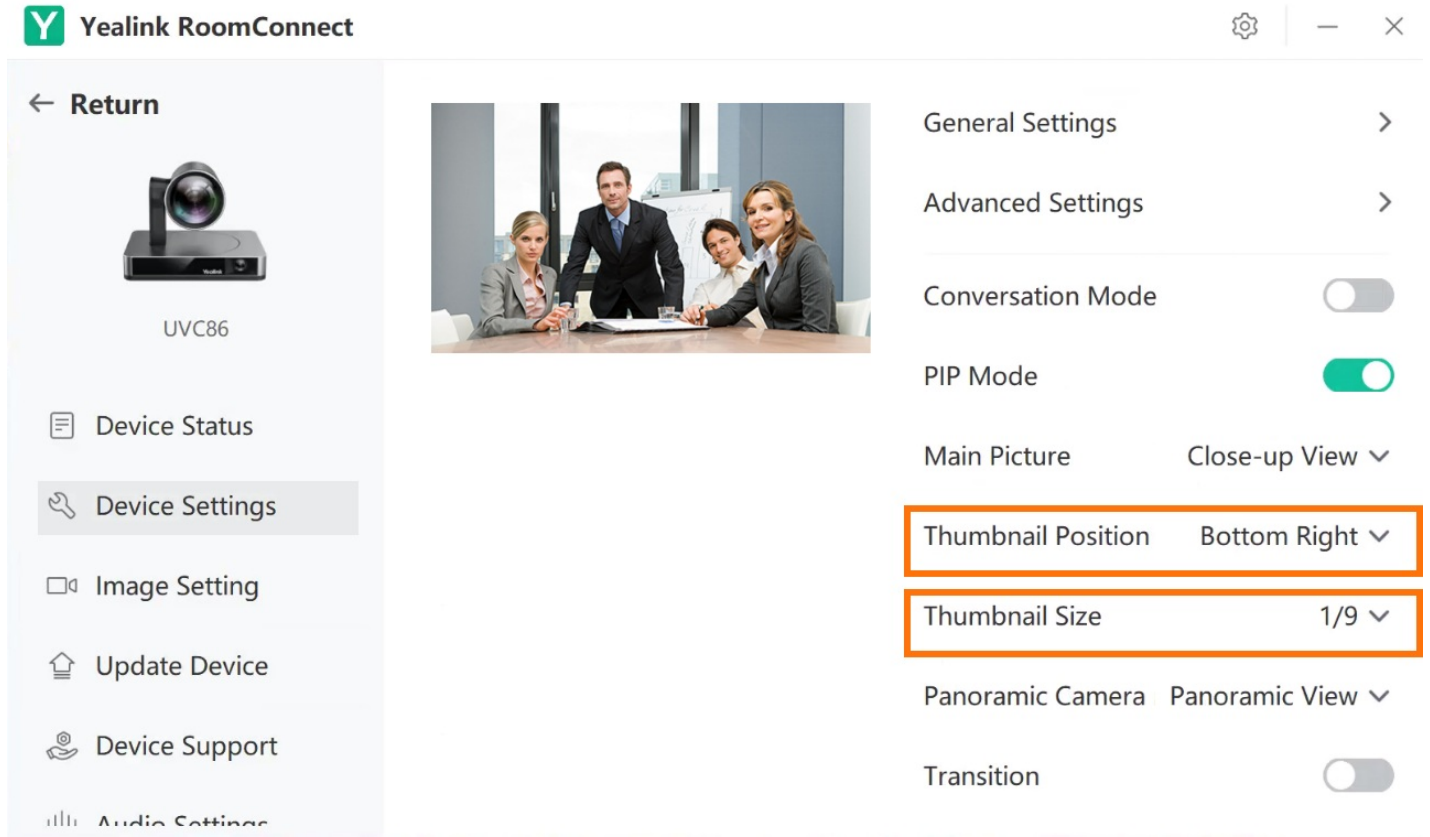

FAQ

The PIP mode is enabled, but only one picture is displayed.

If you enable the **PIP mode** in **Tracking Feature > Speaker Tracking/Presenter Tracking**, the small floating window is displayed only when someone speaks. If you enable the **PIP mode** after disabling **Tracking Feature**, the small floating window always displays on the screen.

Why can't my video camera enable the PIP mode?

The PIP mode is only applicable to UVC86 cameras with software version 151.424. 0.5. rom and later. You cannot enable **PIP mode** when enabling **Auto Framing** and **Multi Focus**.

AVHub & Multi-cameras Settings

Introduction

AVHub supports connecting multiple cameras for the unified management of video devices. With the Yealink RoomConnect application, you can rename/set the image or set the camera layout of the cameras connected to the AVHub.

How to Use

You can directly use the MTouch II matched with MVC to operate or log in to the Yealink Device Management Platform to operate remotely. For the remote control, please refer to [Remote Control](#).

Before you begin: Connect the AVHub to the camera. For more information, please refer to [AVHub Audio & Video Processor](#).

1. Camera Settings

1. You need to switch the system to Windows Mode (For more information, please refer to [Switch Account](#)).
2. Open the Yealink RoomConnect application and select AVHub card.

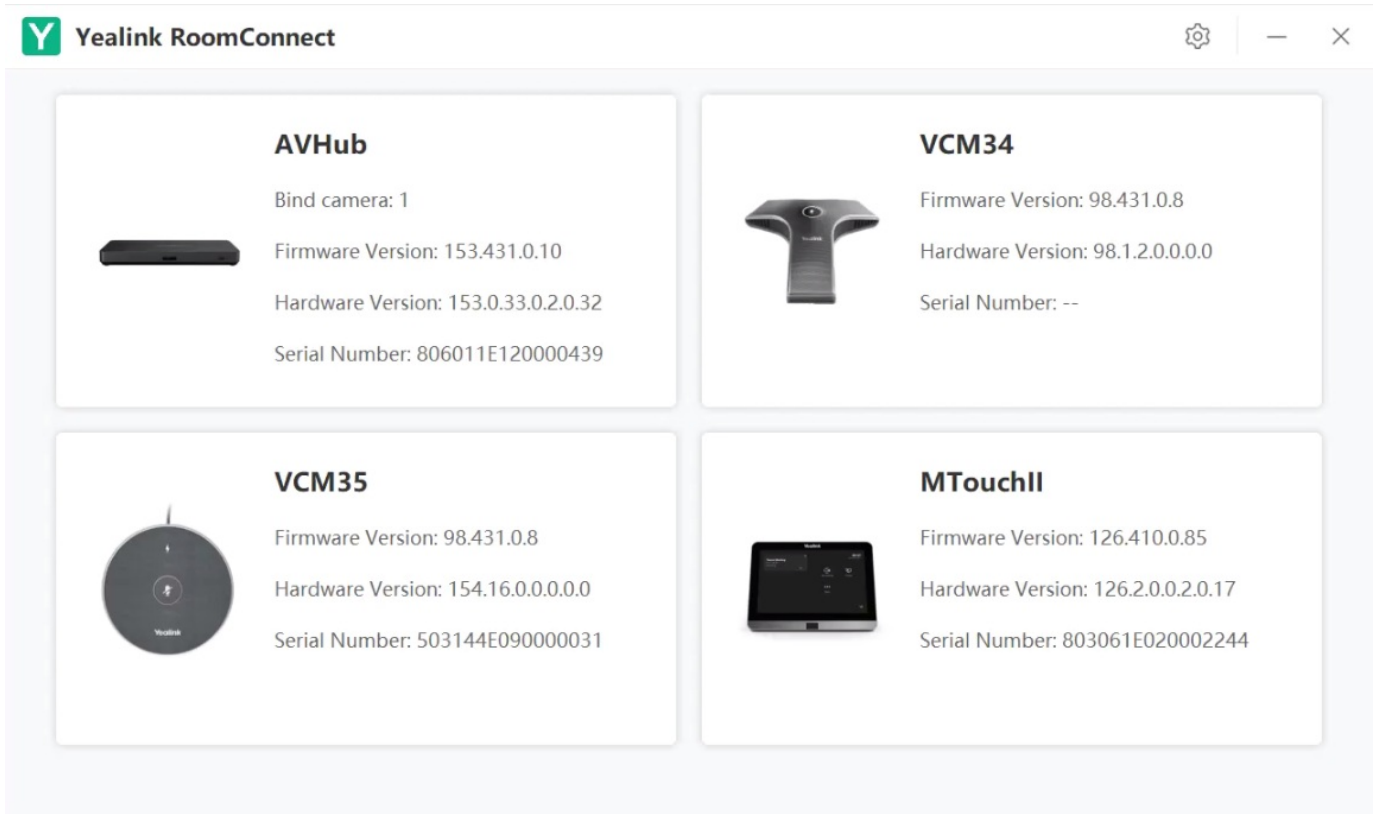

3. Select **Image Setting** to set the camera's name or other settings. For the setting parameters, please refer to [Basic Settings](#).

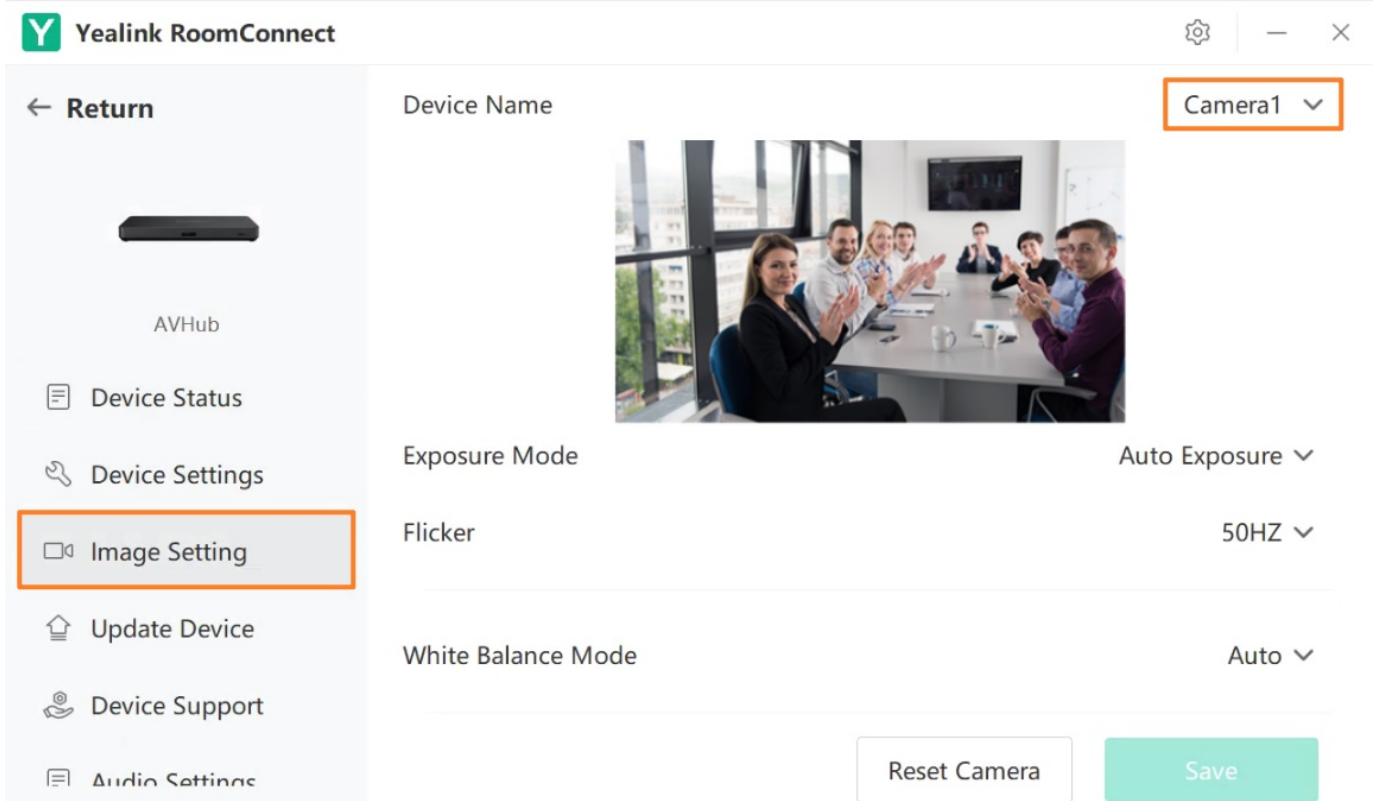

2. Camera Layout

You need to switch the system to Windows Mode (For more information, please refer to [Switch Account](#)).

1. Open the Yealink RoomConnect application and select the AVHub card.

Open the Yealink RoomConnect application and select the AVHub card.

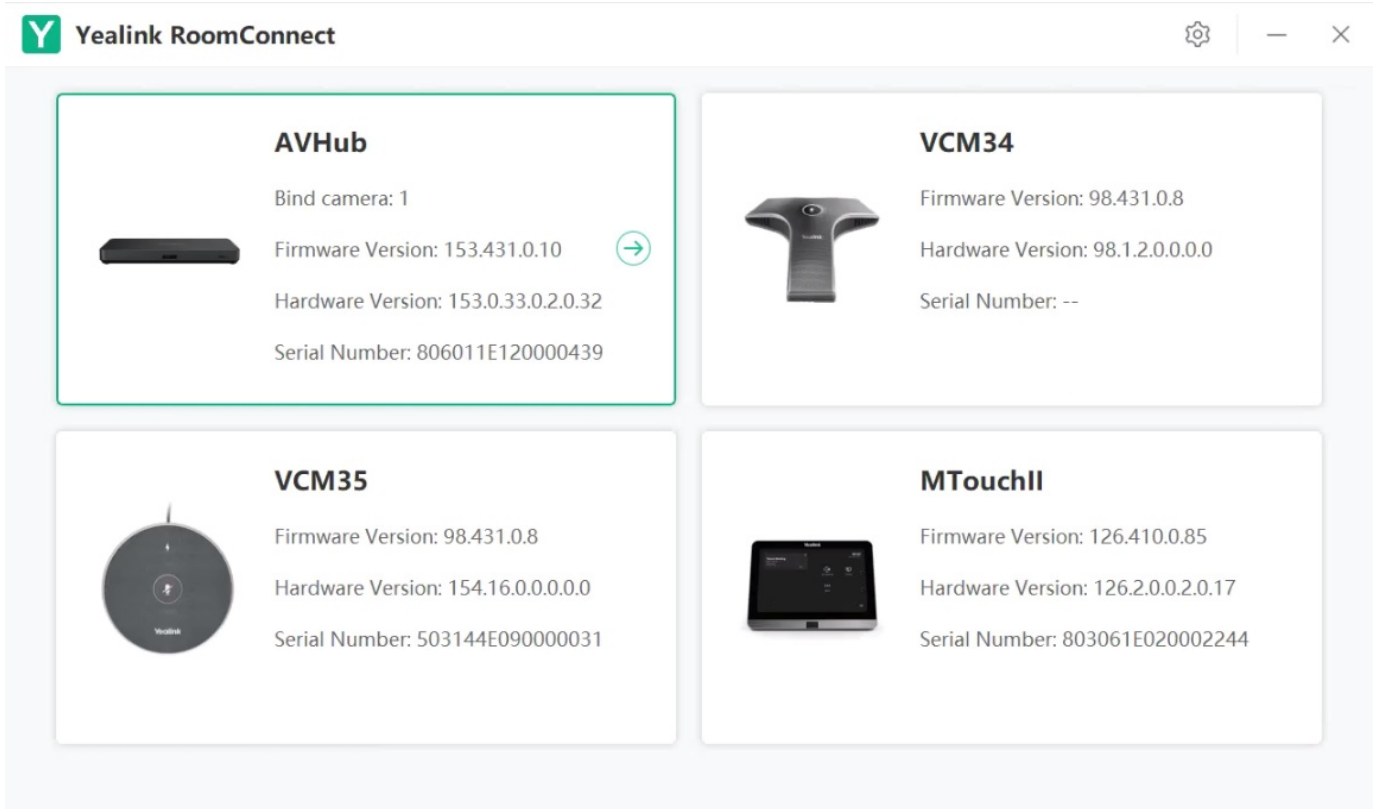

2. Enable **Camera Layout** in **Device Settings**.

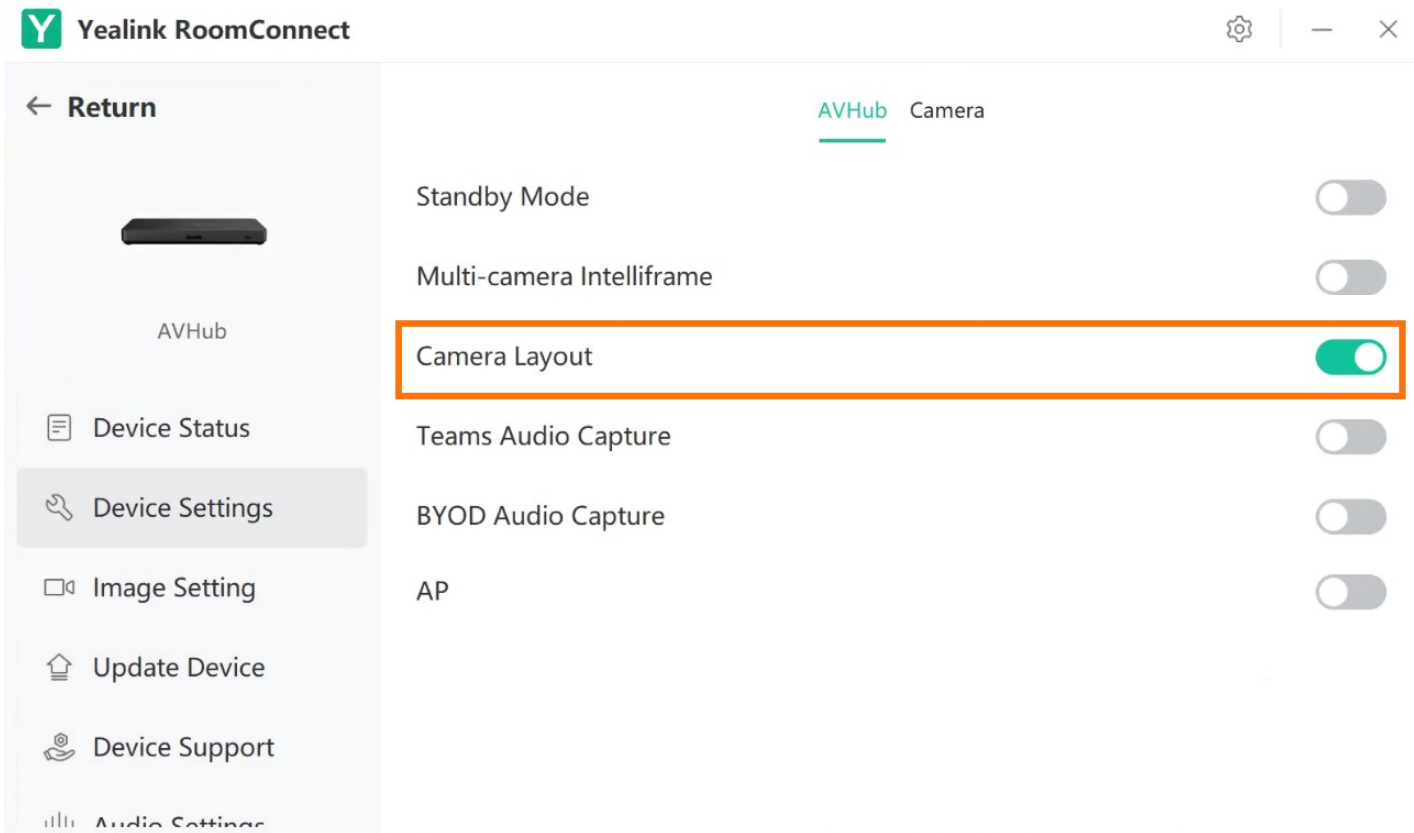

3. Adjust Layout in Microsoft Teams Rooms

You need to switch the system to Microsoft Teams mode (For more information, please refer to [Switch Account](#)).

Set Fullscreen Mode

During a call/meeting, the selected camera picture is displayed in full screen.

1. Select **Room Controls** to enter **Camera Layout**.
2. Select **Fullscreen** in **Layout Mode**.

Select **Add** with the mouse or finger to select a camera that has been connected to AVHub.

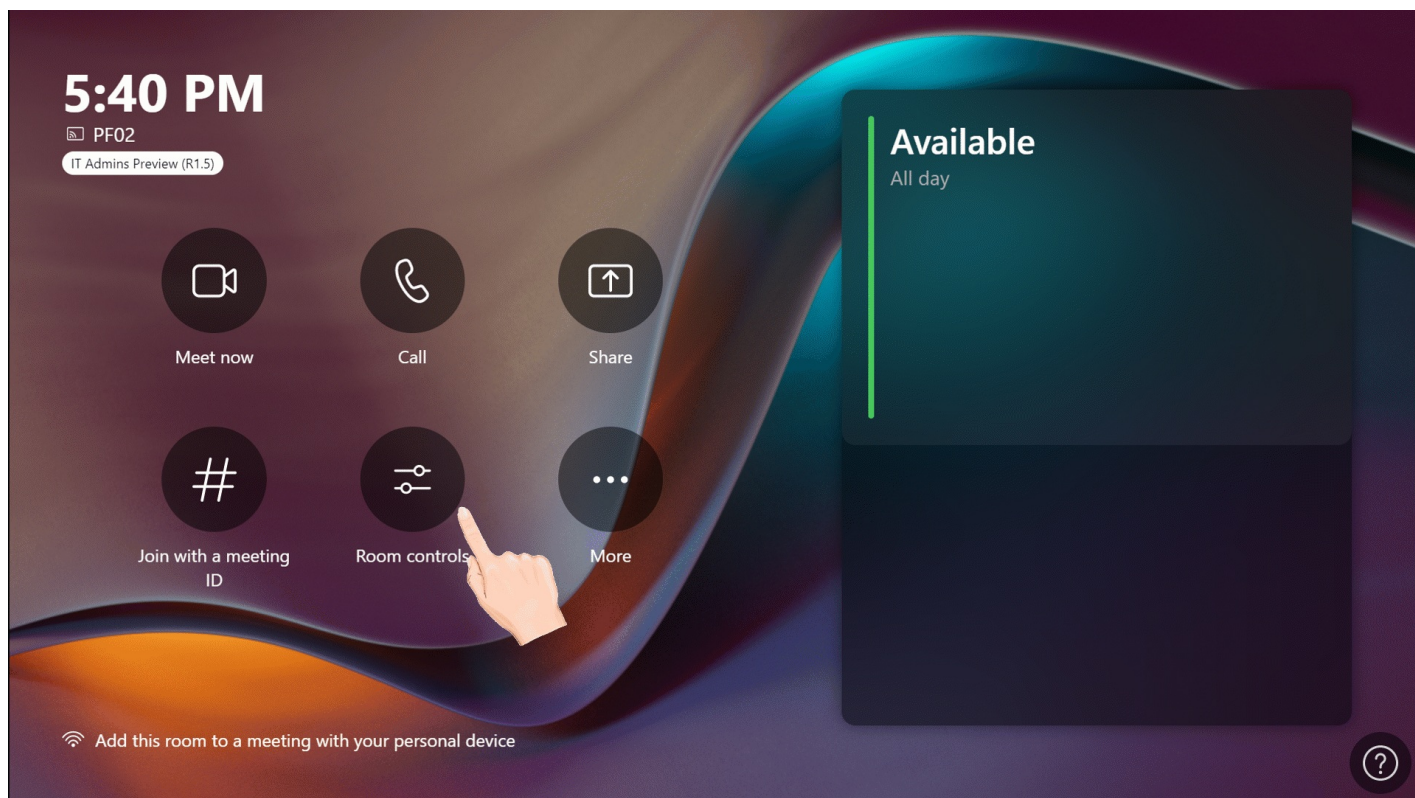

Setting Division Mode

During a call/meeting, the video screen displays each camera in equal parts. The number of equally divided screens can be set from 2 to 9.

1. Select **Room Controls** to enter **Camera Layout**.
2. Select **Division** in **Layout Mode**.

Select **Add** with the mouse or finger to select a camera that has been connected to AVHub.

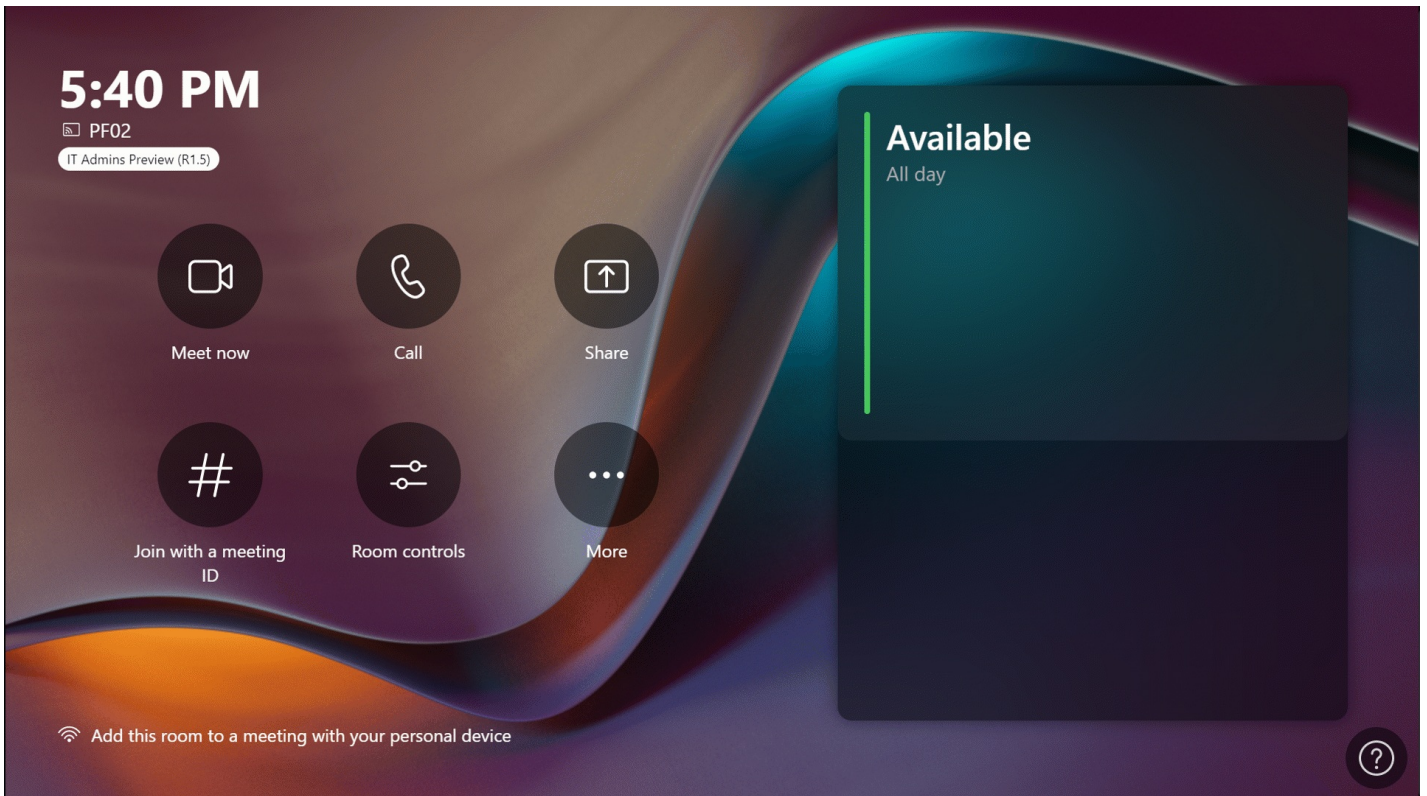

Setting Surround Mode

During a call/meeting, the selected camera screen is displayed in the large window and other camera screens are displayed in small windows. The number of N to the can be set from 1 to 8.

1. Select **Room Controls** to enter **Camera Layout**.
2. Select **Surround** in **Layout Mode**. Select **Add** with the mouse or finger to select a camera that has been connected to AVHub.

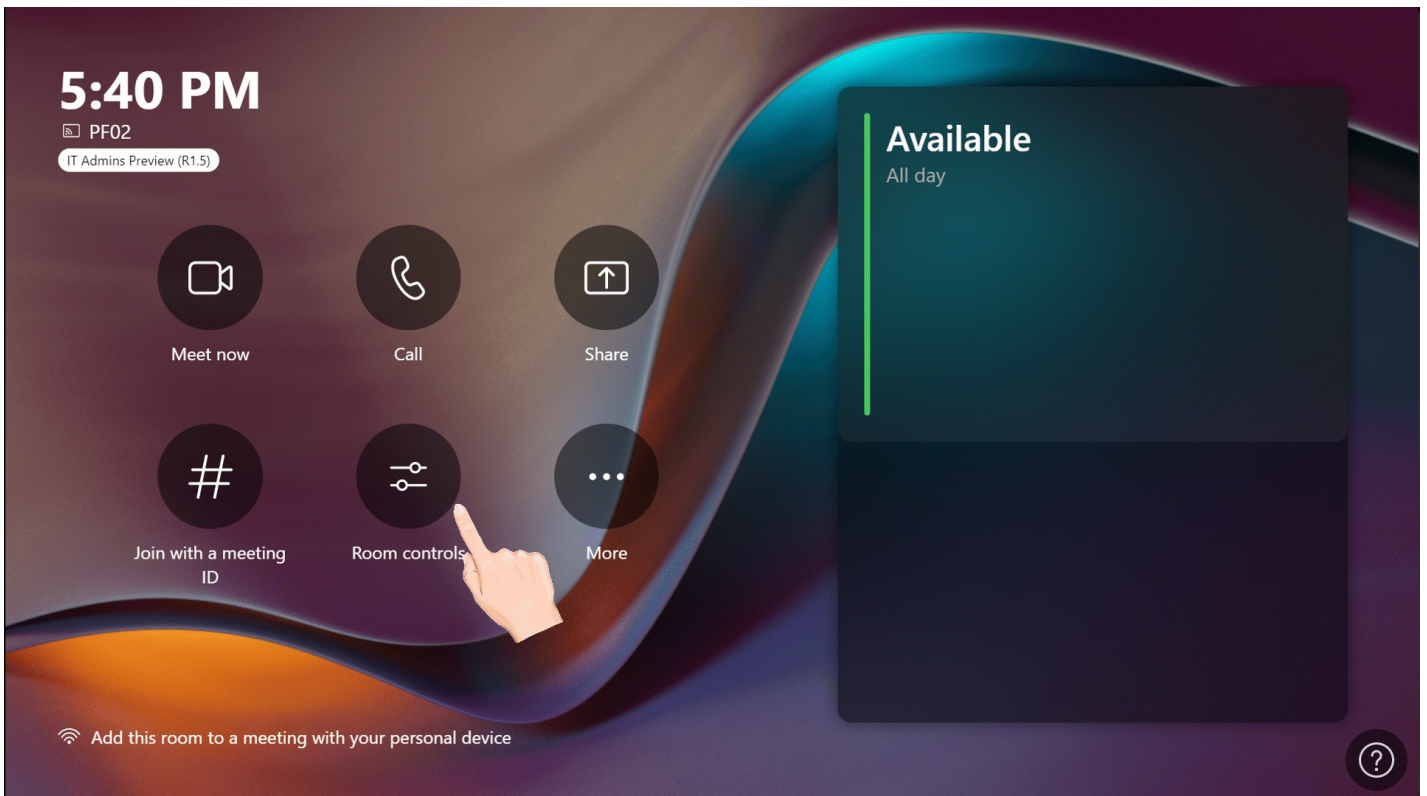

Adjust Camera Layout During the Meeting

You can go to **Meeting > More > Room Controls** to adjust the camera layout during the meeting.

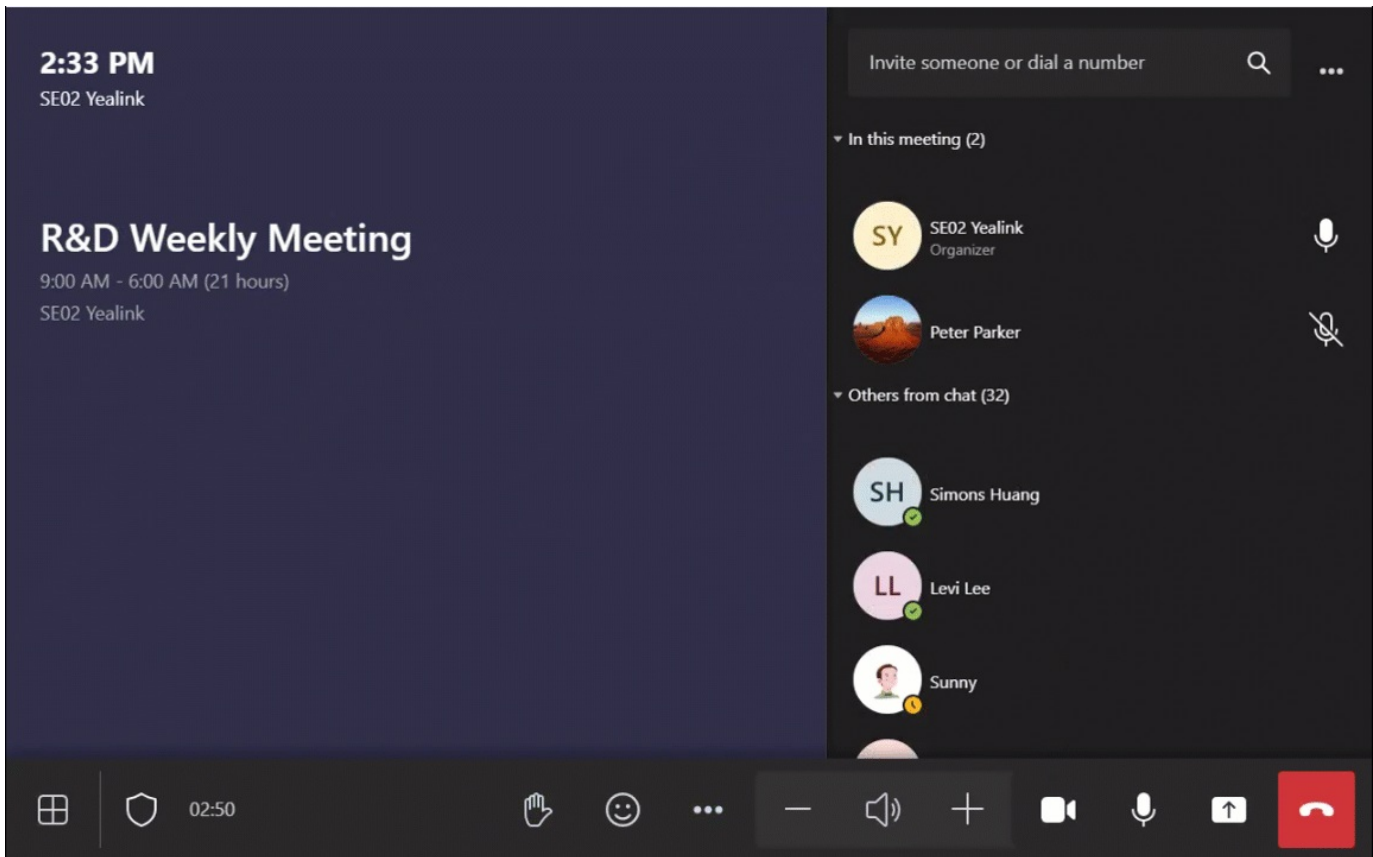

FAQ

Does the AVHub support connect to the Central Control System?

AVHub' s USB connecting solution supports connecting to the central control. For more information, please refer to [Central Control System API Version and Manual](#).

When AVHub is used with VCS system, it does not support central control.

AVHub Mic and Camera Linkage

Introduction

The scenarios of the Mic and Camera Linkage are as follows:

- The screen displays a preset default layout when no one speaks.
- When a speaker unmutes the microphone, the video picture switches to the preset screen of the camera bound to the microphone.
- The other participants' microphones will be muted when another speaker unmutes his microphone. And the video picture displays the preset screen of the camera to which the microphone is bound.
- The video picture switches to the preset default layout when the speaker mutes the microphone.

For the operation video, please refer to [AVHub-Mic & Camera Linkage](#).

NOTE

The Mic and Camera Linkage feature supports using the third-party brand Shure Ceiling microphones. For more information, please refer to [Shure Mic and Camera Linkage](#). If you want to use microphones of other third-party brands, please consult Yealink technical support in advance.

How to Use

You can directly use the MTouch II matched with MVC to operate or log in to the Yealink Device Management Platform to operate remotely. For the remote control, please refer to [Remote Control](#).

Before you begin:

- Version Requirements:

The feature is only applicable to the multi-camera mode of AVHub. The available devices: UVC84/UVC86 camera and VCM34/VCM36 microphone.

- AVHub: 153.430.0.15 and later
- UVC86 Camera: 151.430.0.15 and later
- UVC84 Camera: 262.430.0.15 and later

- The device deployment is as follows:

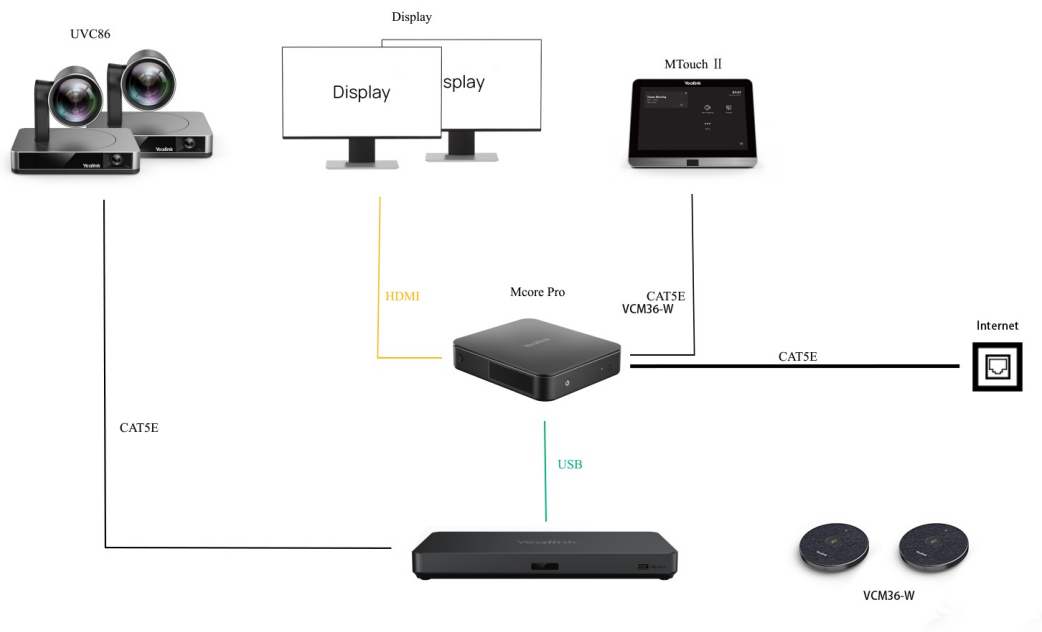

1. Enable Mic and Camera Linkage

1. Open the Yealink RoomConnect application and select the AVHub camera card.
2. Enable **Mic and Camera Linkage**.

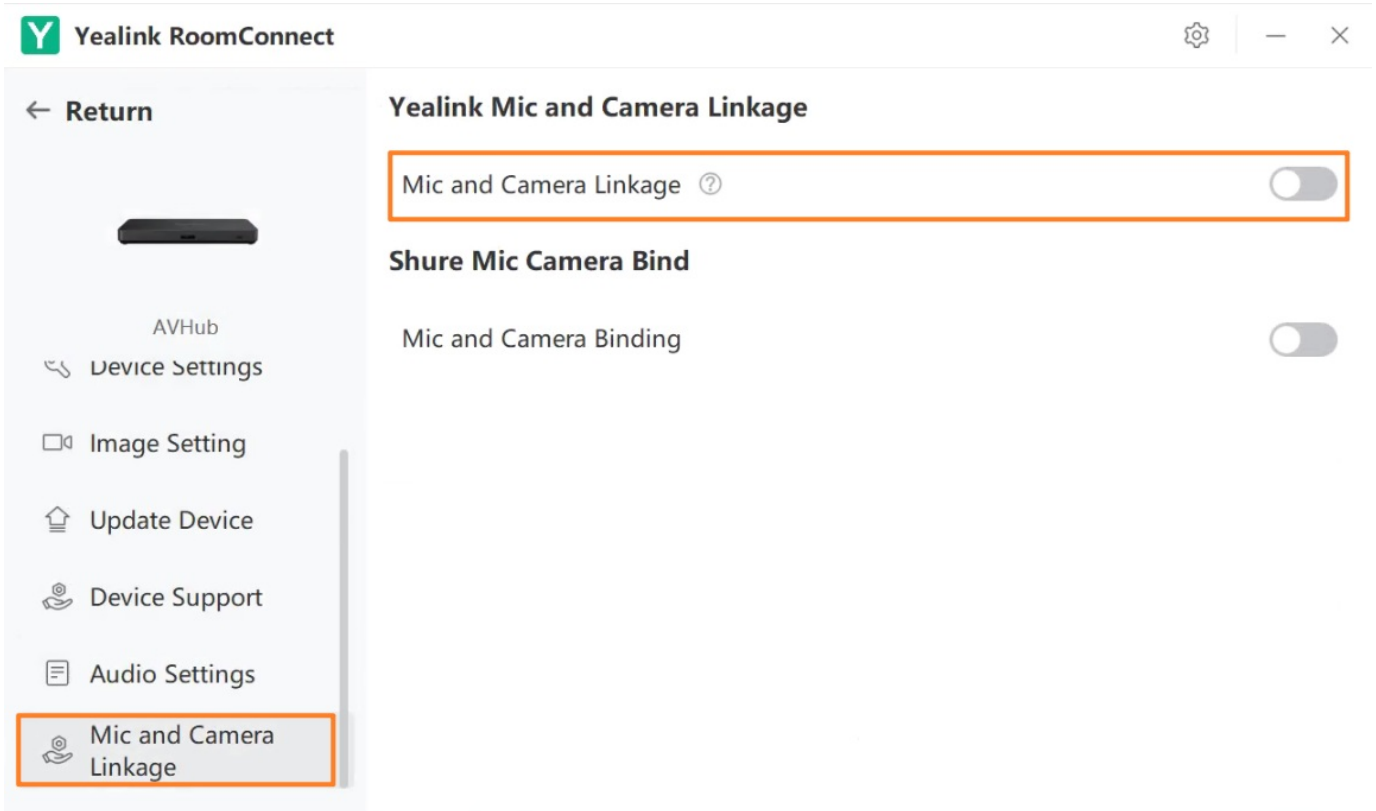

2. Bind to Camera

1. Go to **Mic and Camera Binding**.
2. Select the camera you want to bind and click **Finish**.
 - At this time, the picture adjusted by the camera is the picture that appears after the bound microphone is unmuted. You can set the corresponding speaker in the middle of the picture.
 - The LED indicator of the selected microphone flashes red and green alternately.
 - A camera can be bound to up to 8 microphones.

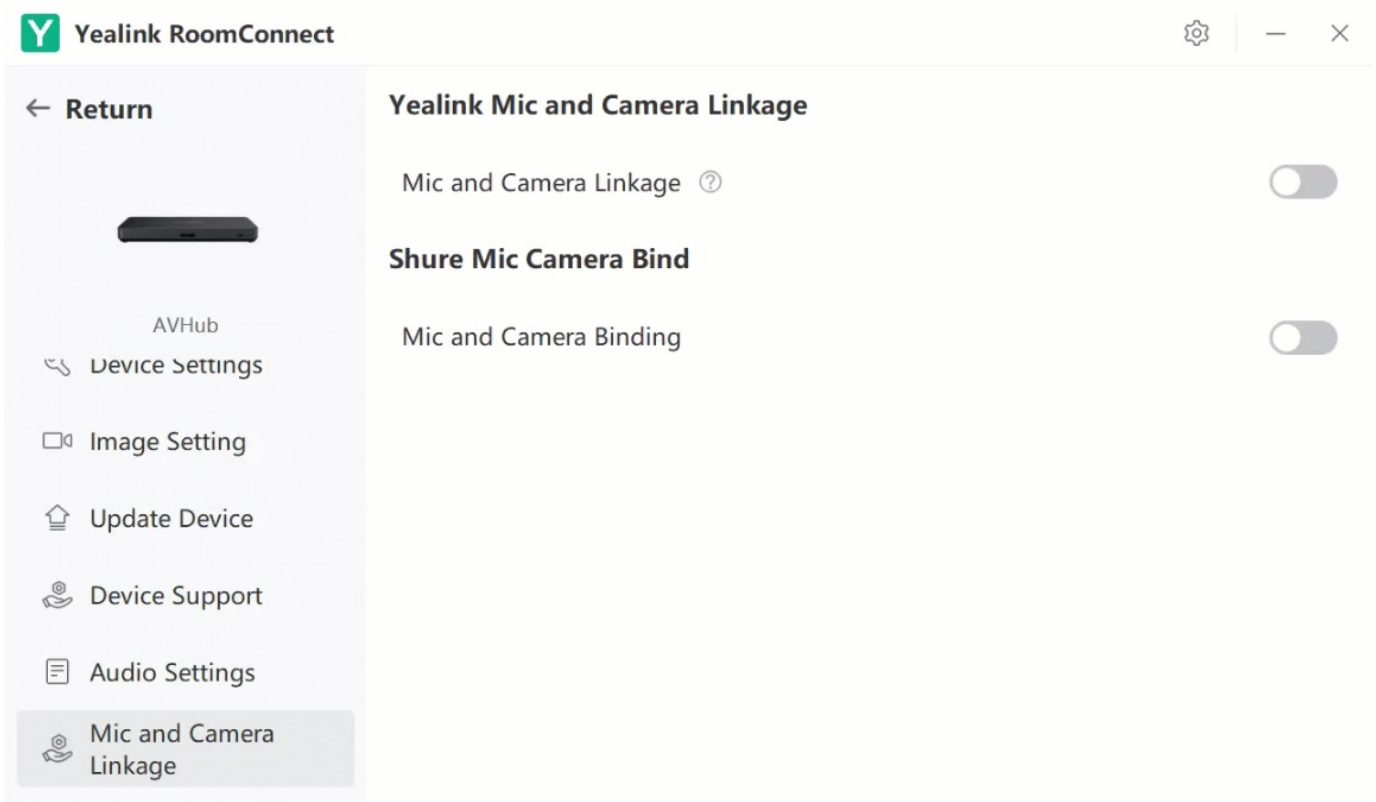

3. Set Camera Default Screen

- **Set the multiple default layouts**

1. Go to **Mic and Camera Linkage > Default camera layout and position > CameraLayout** to select layout (**Full screen/Division/Surround**).
2. Select + to add a camera.
3. Select **Preview** to view the screen effect.

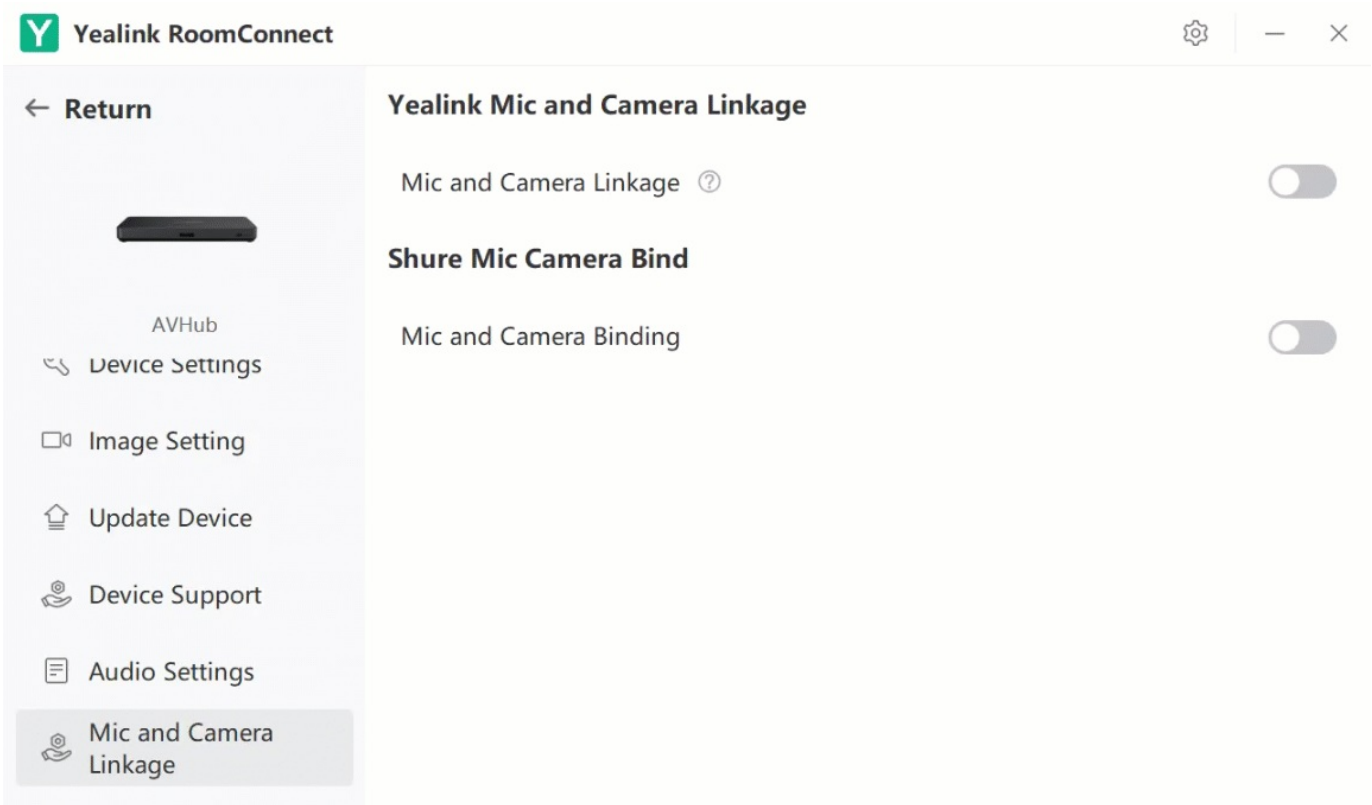

- **Set a single default layout**

1. Go to **Mic and Camera Linkage > Default Screen > Camera Control** to adjust each camera' s angle and focal length.

2. Select **Finish**.

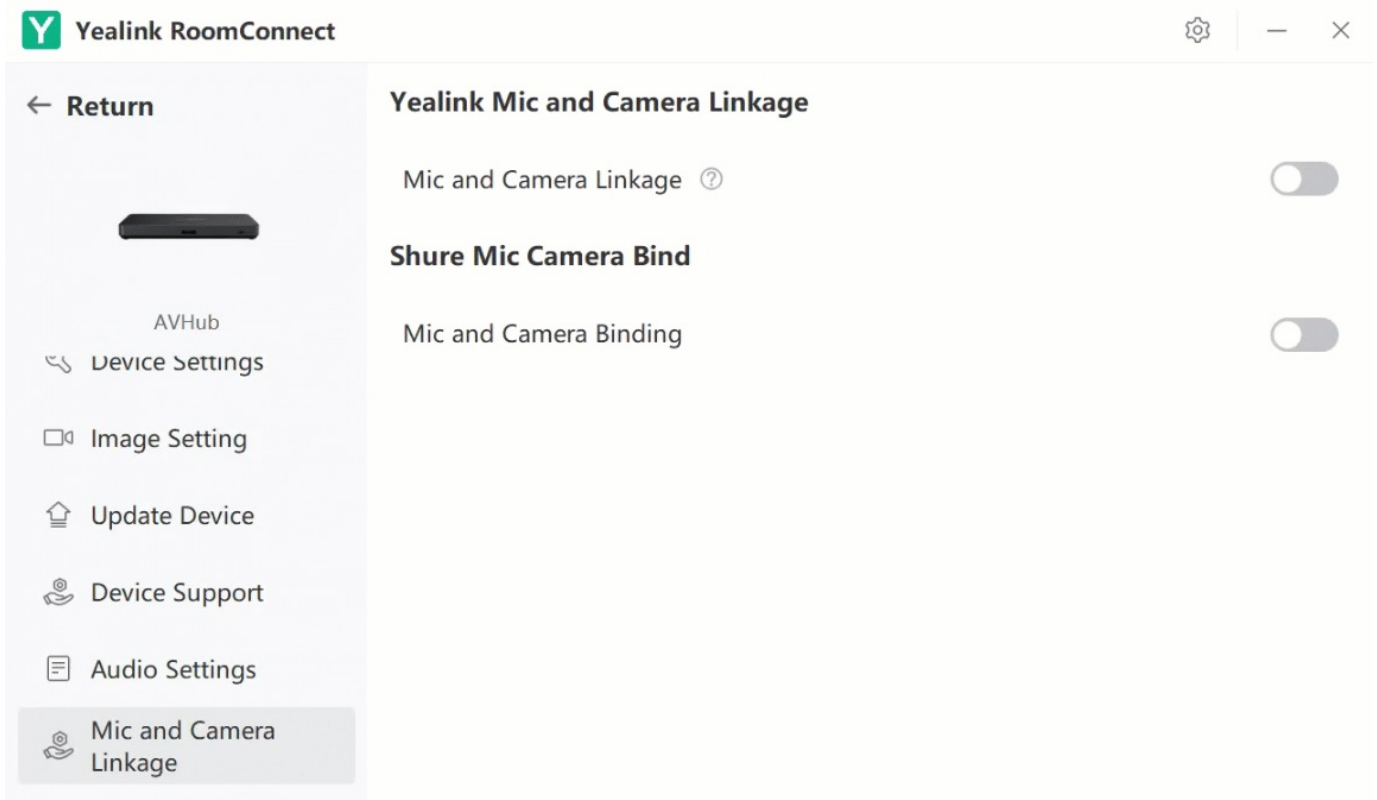

NOTE

After adjusting the camera control, you can select Preview in the camera layout again to view the screen effect.

FAQ

Does the Mic and Camera Linkage feature work with third-party microphones?

When you use the camera, the camera enters sleep mode.

The camera that has not been used for a while will enter sleep mode. When you use it again, the screen will display the picture of restarting the camera. We recommend that you enable Standby mode to get a better experience. The method is as follows:

You need to switch the system to Windows Mode (For more information, please refer to [Switch Account](#)).

1. Open the Yealink RoomConnect application and select the camera card.
2. Go to **AVHub > Settings > Standby mode**.

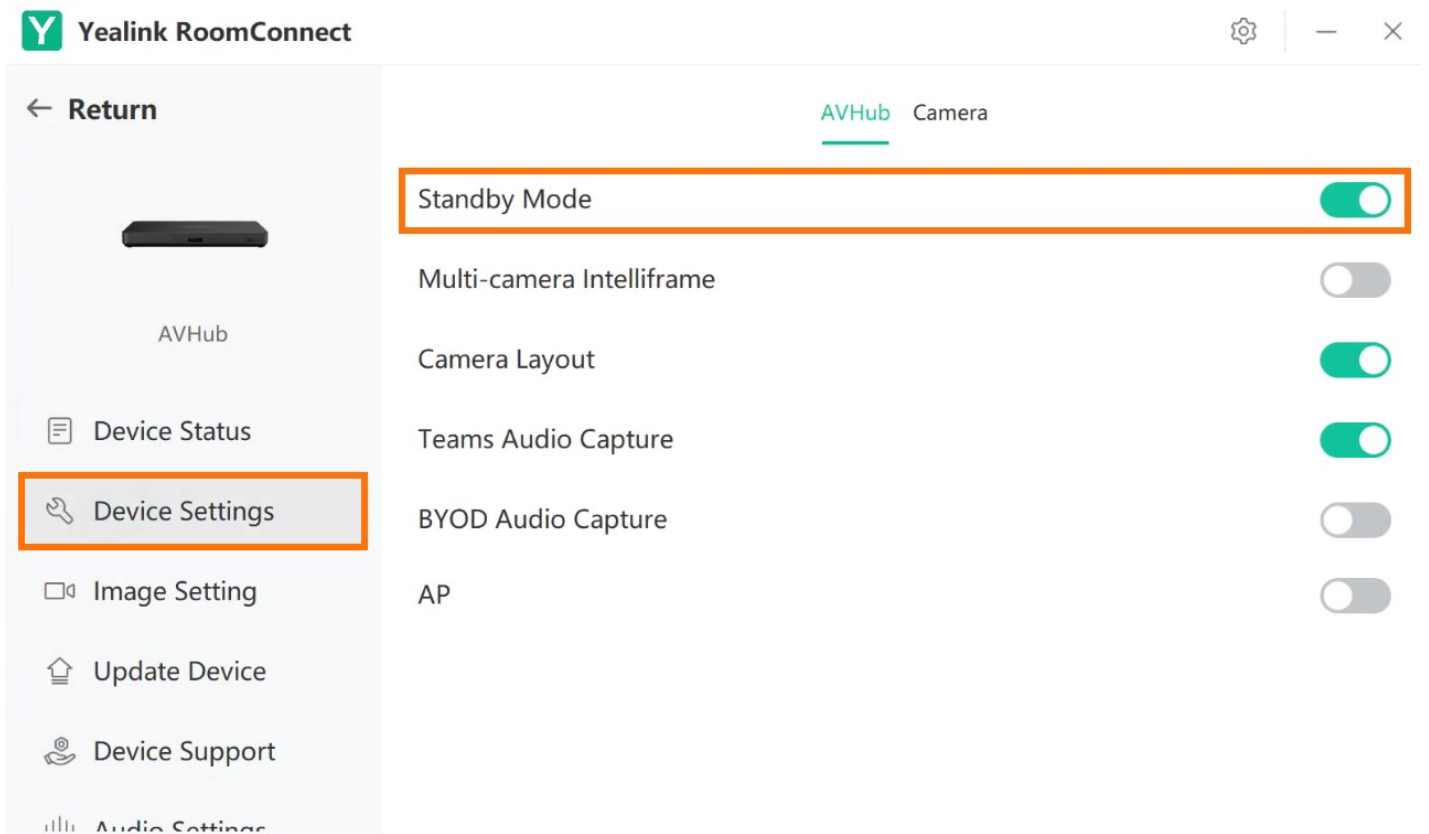

Shure Mic and Camera Linkage

Introduction

The Mic and Camera Linkage feature supports using the third-party brand Shure Ceiling microphones to use Shure Mic and Camera Linkage. For the operation video, please refer to [Shure Microphone-Mic & Camera Linkage](#).

How to Use

You can directly use the MTouch II matched with MVC to operate or log in to the Yealink Device Management Platform to operate remotely. For the remote control, please refer to [Remote Control](#).

Before you begin:

- Version Requirements:
 - AVHub: 153.430.0.15 and later
 - UVC86 Camera: 151.430.0.15 and later
 - UVC84 Camera: 262.430.0.15 and later

- The device deployment is as follows:

NOTE

Do not connect other audio devices to AVHub after deployment. If you want to add audio devices, please connect them to Shure P300.

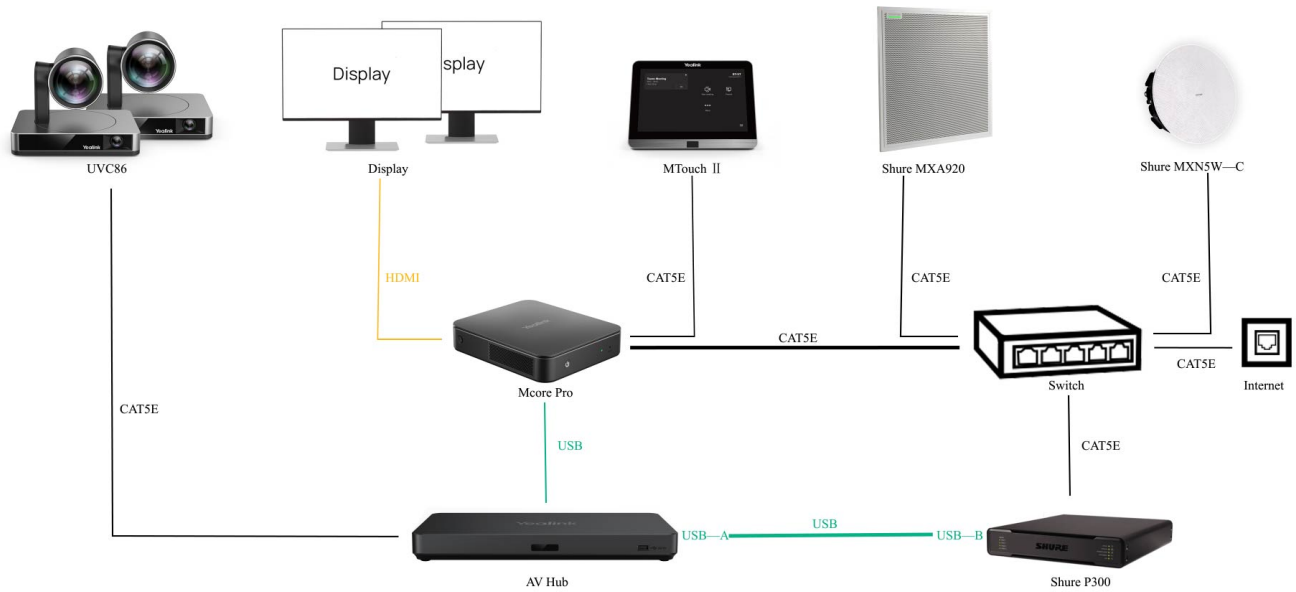

1. Configure Microphone in Shure Design

- Go to **Settings** in the Shure Designer, and click **Refresh**.
- Go to **Online device** to find the microphone's IP address in the Shure Designer.

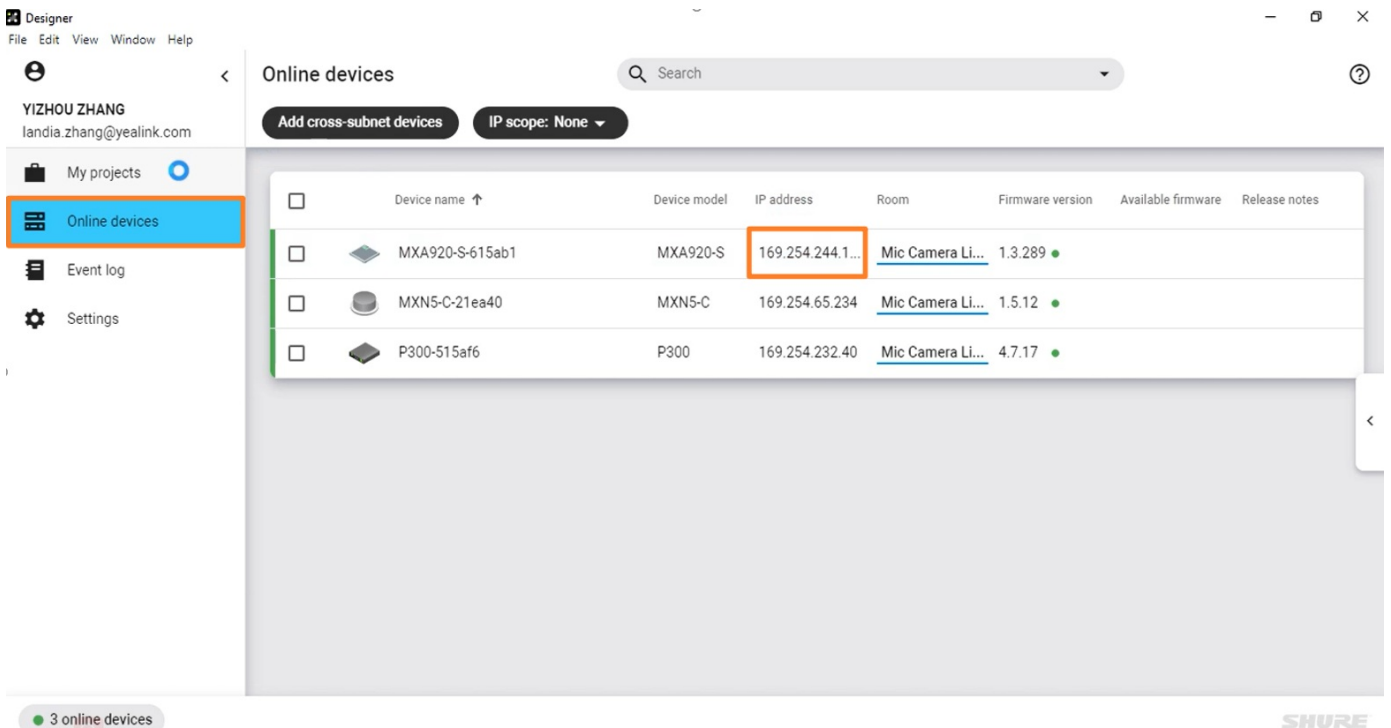

- Create a microphone channel and set coverage.

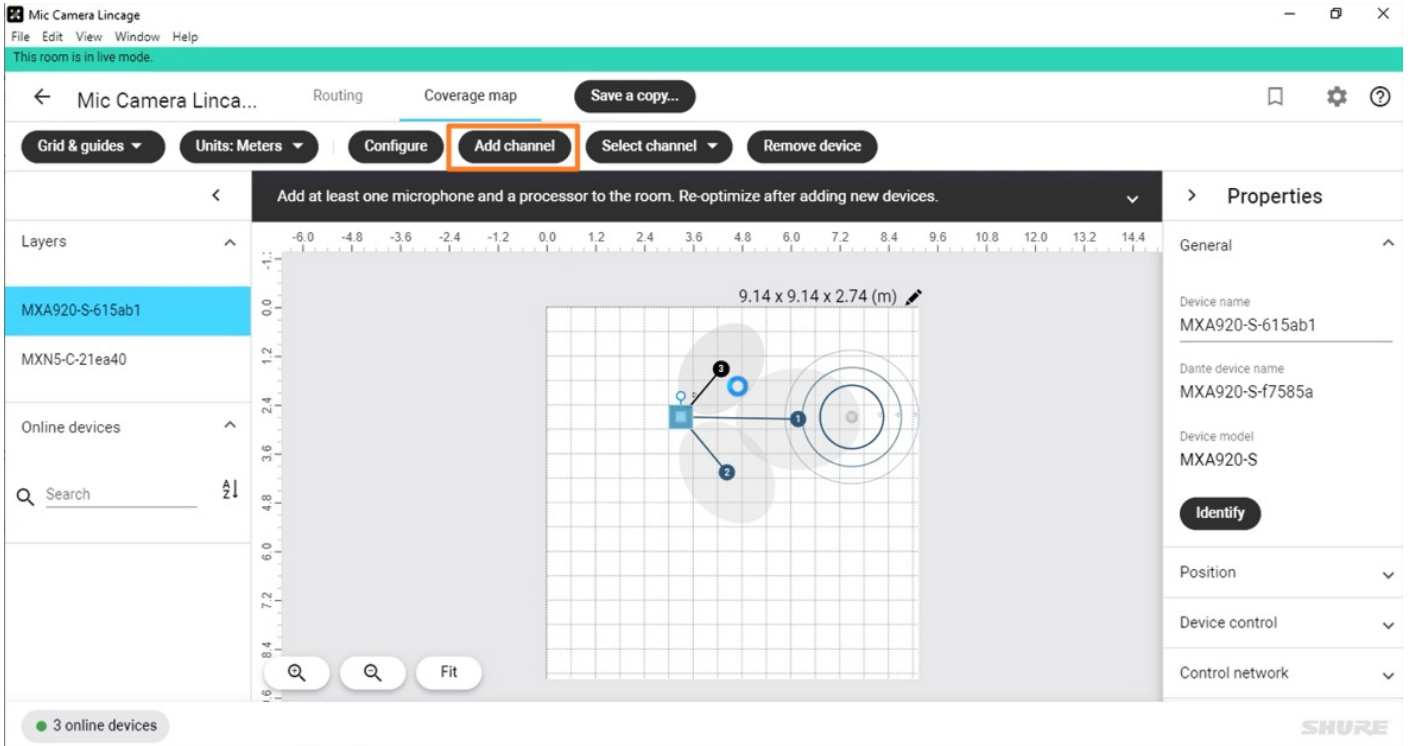

4. Enter the microphone MXA920 menu and click the **IntelliMix** page.

Set the **Hold time** value to 1500 ms to capture better audio performance. However, switching cameras will cause a slight delay (Please confirm the meeting room's sound environment and delay parameters, and use a shorter Hold time in a single source environment).

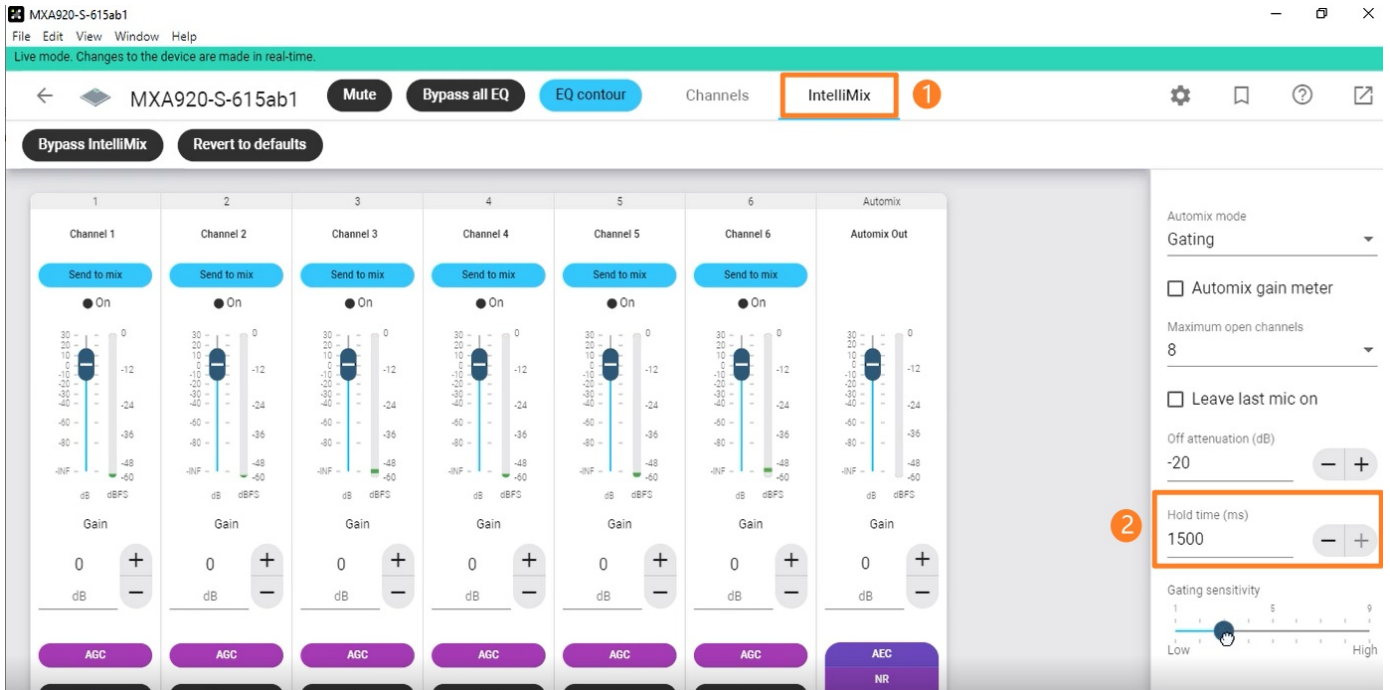

2. Configure Shure Mic and Camera Linkage in YRC

1. Open the Yealink RoomConnect application and select the AVHub card.

Go to **Mic and Camera Linkage** to enable **Mic and Camera Binding** in **Shure Mic Camera Bind**.

Yealink RoomConnect



← Return



AVHub

Image Setting

Update Device

Device Support

Audio Settings

Mic and Camera Linkage

Divisible Room

Yealink Mic and Camera Linkage

Mic and Camera Linkage ?

Mic and Camera Binding >

Default camera layout and position ?

Camera Layout >

Camera Control >

Shure Mic Camera Bind

Mic and Camera Binding

NOTE

The camera that has not been used for a while will enter sleep mode. When you use it again, the screen will display the picture of restarting the camera. We recommend turning on the standby mode of the camera to avoid affecting the user experience.

- 1). Open the Yealink RoomConnect application and select the Avhub card.
- 2). Go to **AVHub > Device Settings > AVHub > Standby mode**.

Yealink RoomConnect



← Return



AVHub

Device Status

Device Settings

Image Setting

Update Device

Device Support

Audio Settings

AVHub Camera

Standby Mode

Multi-camera Intelliframe

Camera Layout

Teams Audio Capture

BYOD Audio Capture

AP

SSID Yealink-F9D8D5-5G

AP-Channel Auto ▼

- After enabling the Shure microphone binding, if **Not connected** is still displayed under the configuration item, click **Not connected**. Enter the IP address obtained in the first step on the configuration page, and click **Connect**.

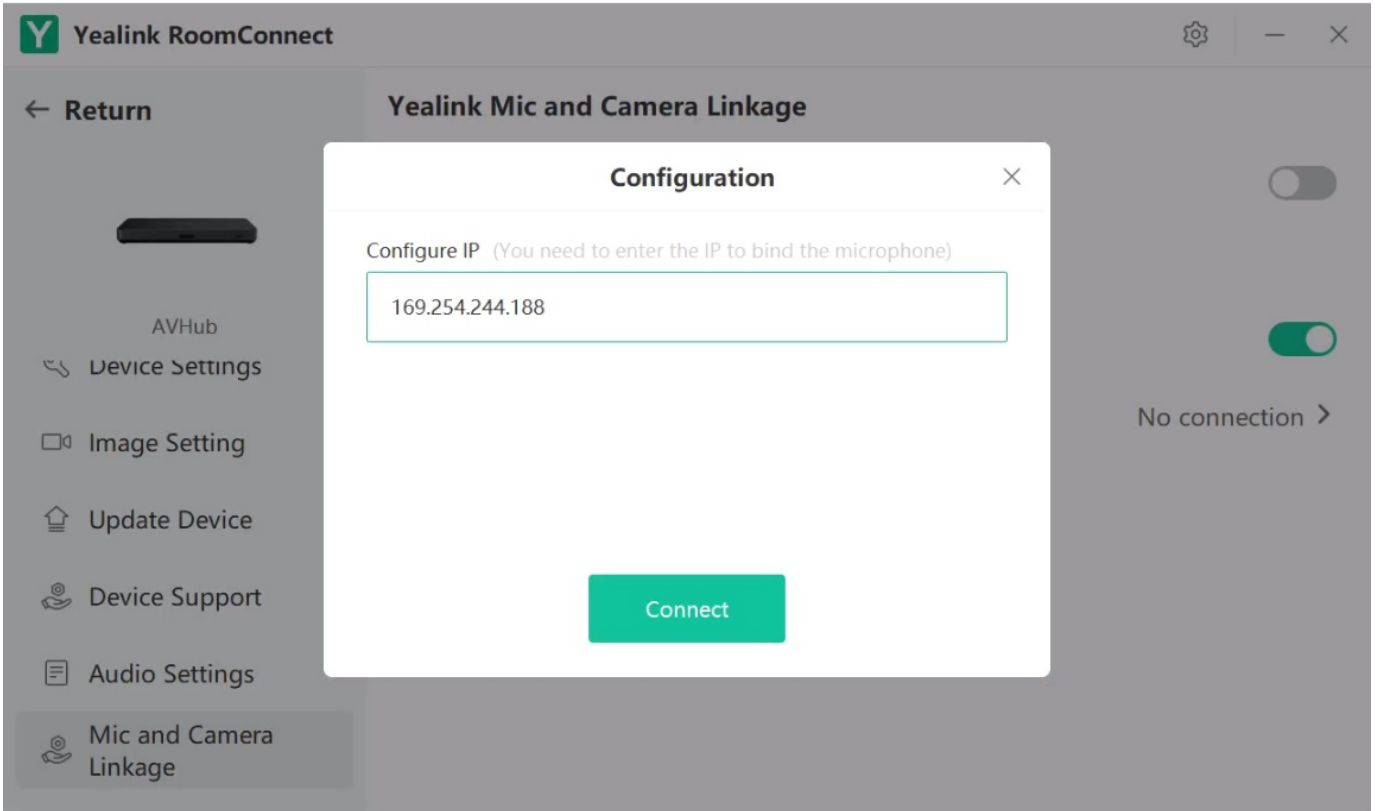

- After the connection is successful, you can see two configuration items: **Mic and Camera Binding** and **Mic and Camera Settings**.

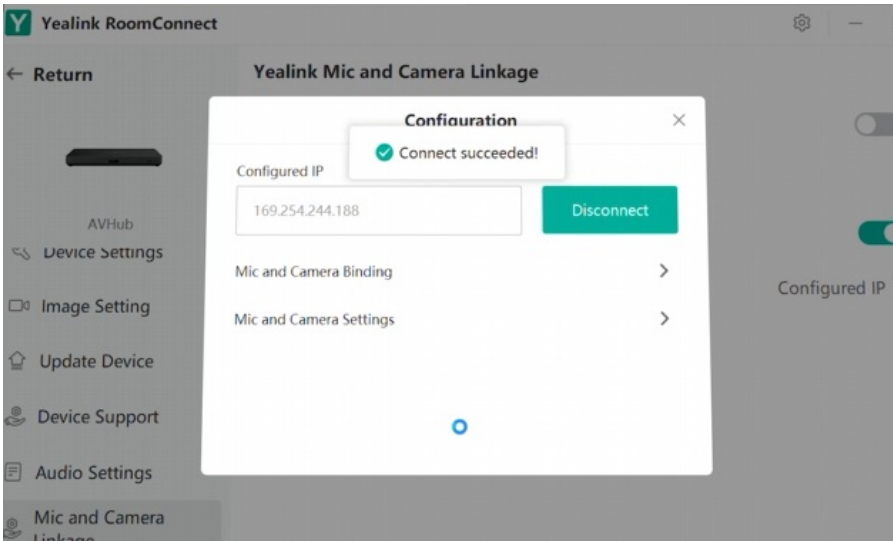

5. Select a microphone channel in **Mic and Camera Binding** to bind a camera.

You can set the camera preset for the bonded camera in advance or set it as a presentation tracking. If the camera preset is set in advance, you can select the camera preset to bind. The video will display the bound camera preset when the microphone channel is enabled. If the presentation tracking is set in advance, the video will display the presentation tracking when the microphone channel is enabled.

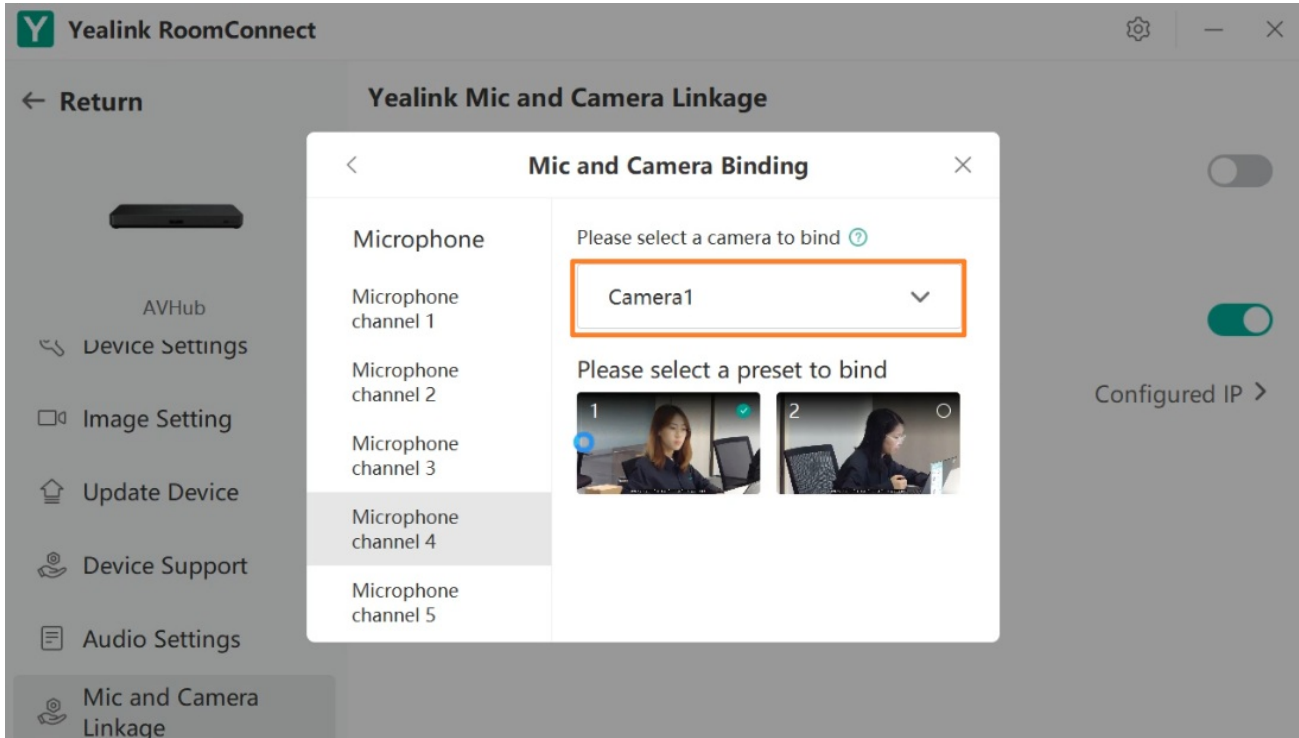

6. Click **Mic and Camera Settings** to set other configurations.

Preset waiting time: Set the time interval for switching the video screen each time. **Default:** 1 second, optional 0.5 - 5 seconds.

Waiting time for returning to default position when no one speaks : Set the time to restore the default video screen when all microphone channels are disabled.

Default Layout: Set the default video layout, camera angle, and focal length when all microphone channels are disabled.

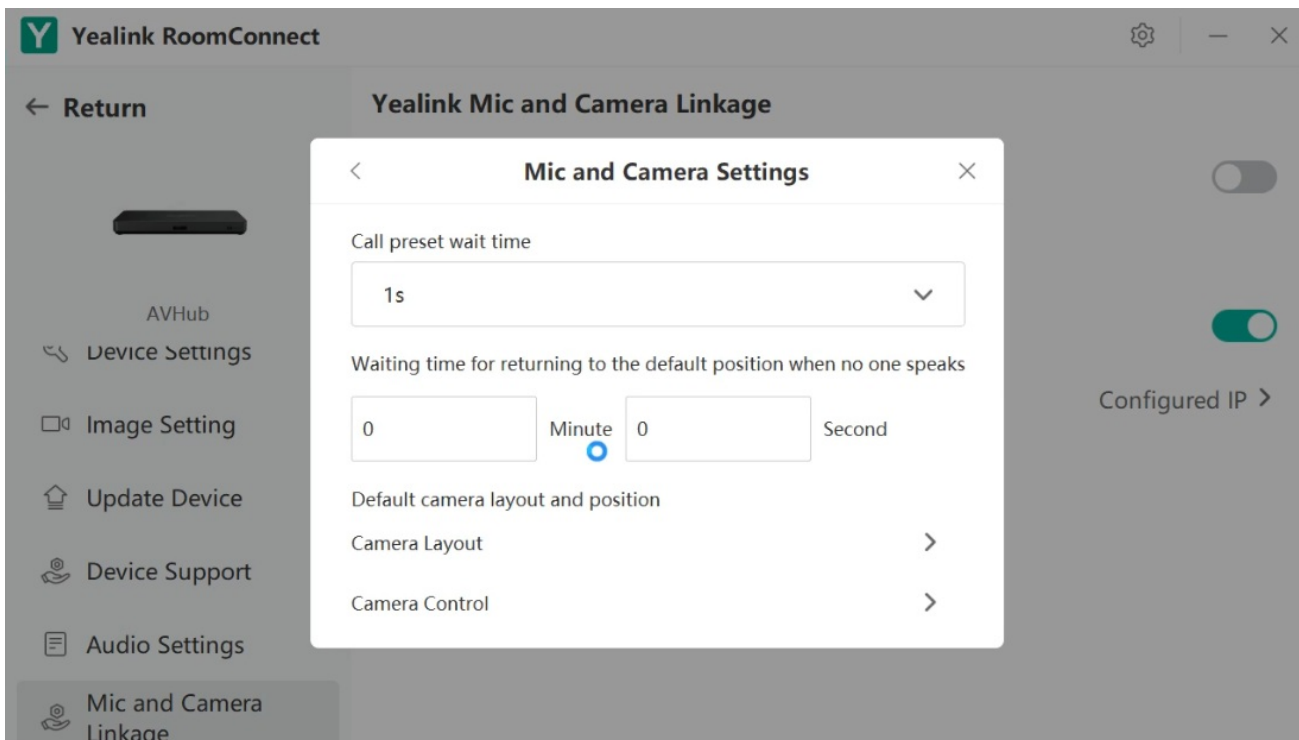

7. After setting, click **Preview** or **Finish**.

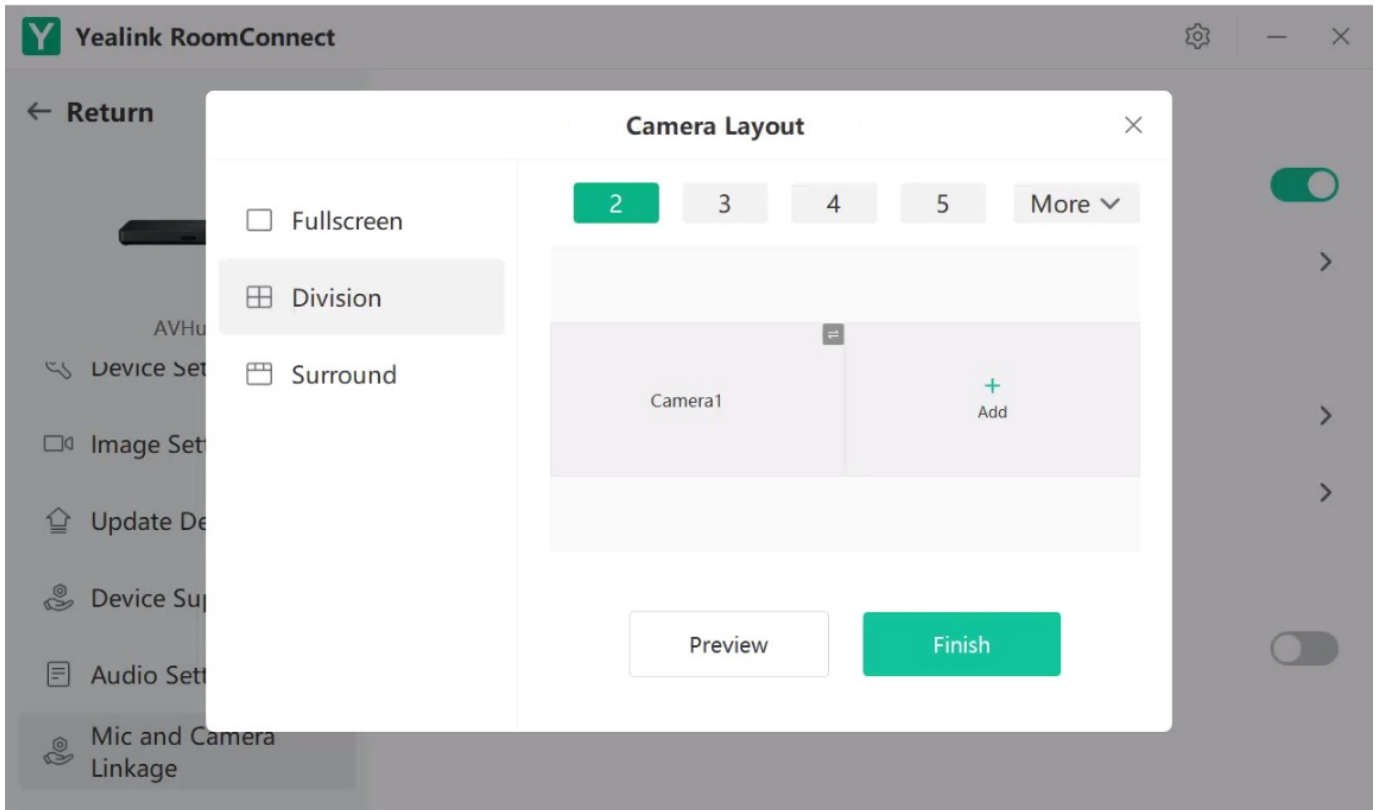

Multi-Camera Intelliframe

Introduction

Yealink AVHub supports Multi-Camera Intelliframe feature. With a simple deployment configuration, you can control 2-9 cameras in the meeting room to track the speakers without the need for additional microphones. In a multi-speaker layout, it can simultaneously display high-definition portraits of up to 4 speakers. Enabling the multi-speaker tracking feature will trigger a restart of AVHub.

Before You Begin

- You can operate the system directly using the MTouch II provided with the MVC series, or you can access the device management platform for remote operation. For remote management instructions, please refer to [Remote Control](#).
- AVHub is supported in 153.432.0.5 and later versions.
UVC86 is supported in 151.432.0.5 and later versions.
Yealink RoomConnect is supported in 3.32.42.0 and later versions.

• Device Combinations:

Below, you'll find common meeting room deployment scheme topologies.



NOTE

When the total number of your UCV cameras and MSpeaker speakers exceeds four units, you will need to provide power to the cameras and speakers through an external POE.

Deployment Recommendations

At present, the UVC86 offers two meeting room modes for you. You can select the mode that corresponds to your actual meeting room layout.

NOTE

To ensure a great meeting experience, please be sure to choose the appropriate mode based on your meeting room layout.

Layout Type 1:

This layout mode is suitable for horizontal meeting rooms, as illustrated in the diagram below using a single camera for deployment principle:

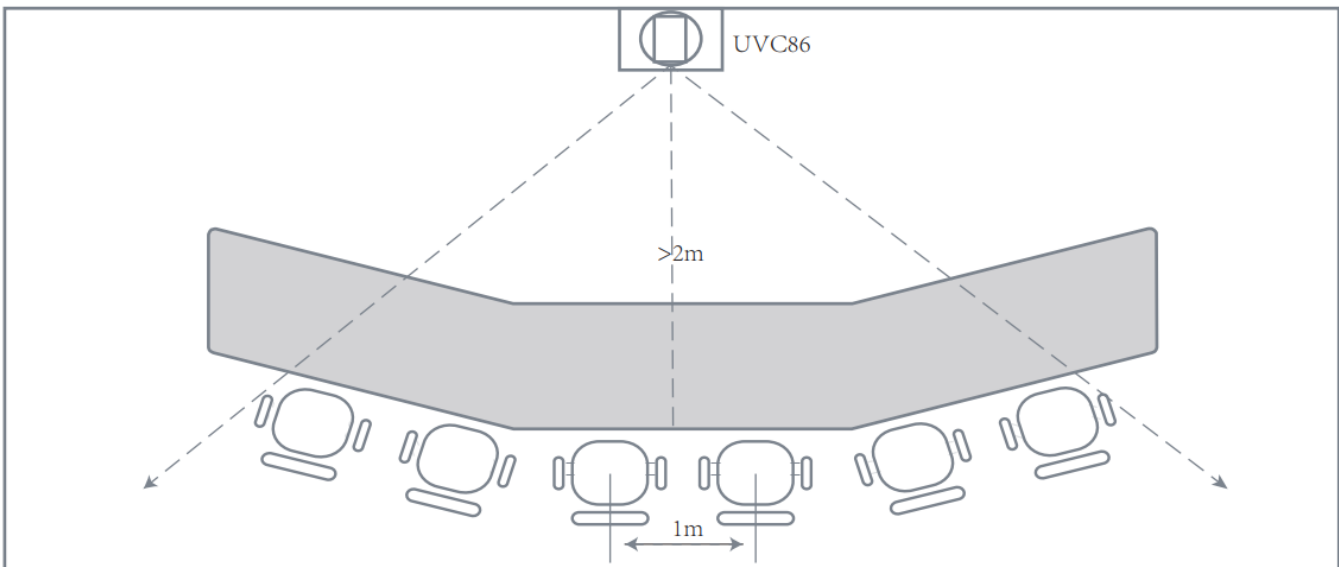

Deployment Recommendations:

1. For horizontal meeting rooms, we recommend that deploy devices at a height of 1m-2.5m.
2. The distance between devices should be at least 3m.
3. Select the device deployment height based on the position of the people. For example, if people are 2m away from the device, the device should ideally be no more than 1.5m above the ground.
4. The spacing between seats in the meeting room should be greater than 0.5m.

NOTE

This feature requires a minimum of two UVC86 cameras to be used. The diagram above provides an overview of the principle. Please ensure you have a sufficient number of cameras.

Layout Type 2:

This layout type is suitable for vertical meeting rooms and is suitable for medium to large meeting rooms with the room structure as shown in the diagram below:

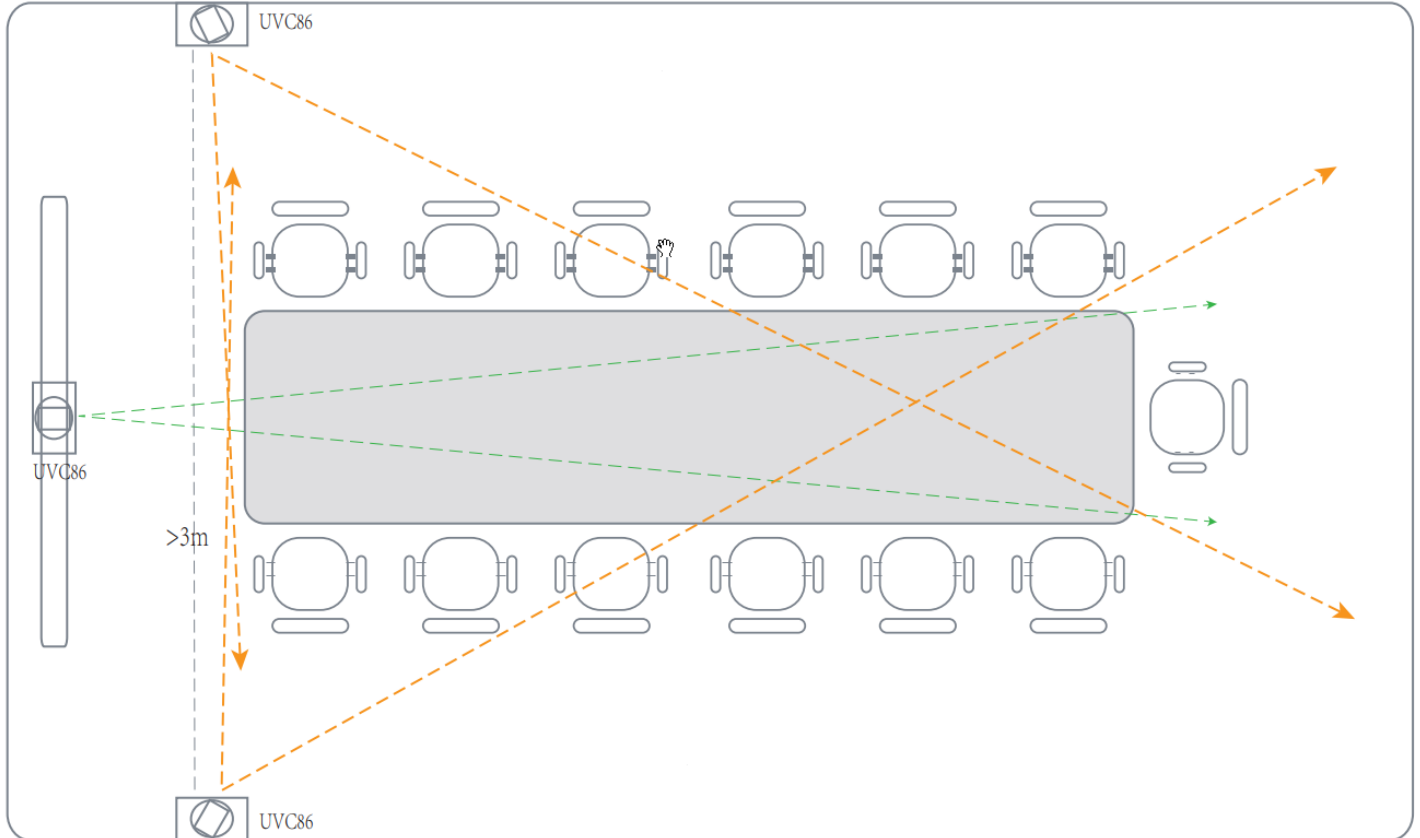
**Deployment Recommendations:**

1. UVC86 should not be deployed in the corners of the meeting room, i.e., at wall junctions.
2. We recommend that deploy at a height of 2 meters or higher.
3. Maintain a distance of approximately 3 meters between devices.
4. Avoid deploying near air conditioning vents.
5. Ensure that each camera's coverage area does not overlap for speakers. If multiple people need to be tracked, consider adding additional UVC cameras as needed.

Configuration Steps

Before using the Multi-Camera Intelliframe feature, there are some basic configurations you need to perform to ensure your user experience. The main configuration is for Layout Type 2, which is suitable for medium to large meeting rooms. Please make sure your multi-speaker feature is enabled.

TIP

When you enable the Multi-Speaker Tracking feature, AVHub will automatically restart.

Layout Type 1(Suitable for horizontal meeting rooms)

1. Go to AVHub > Device Settings > Layout Type 1

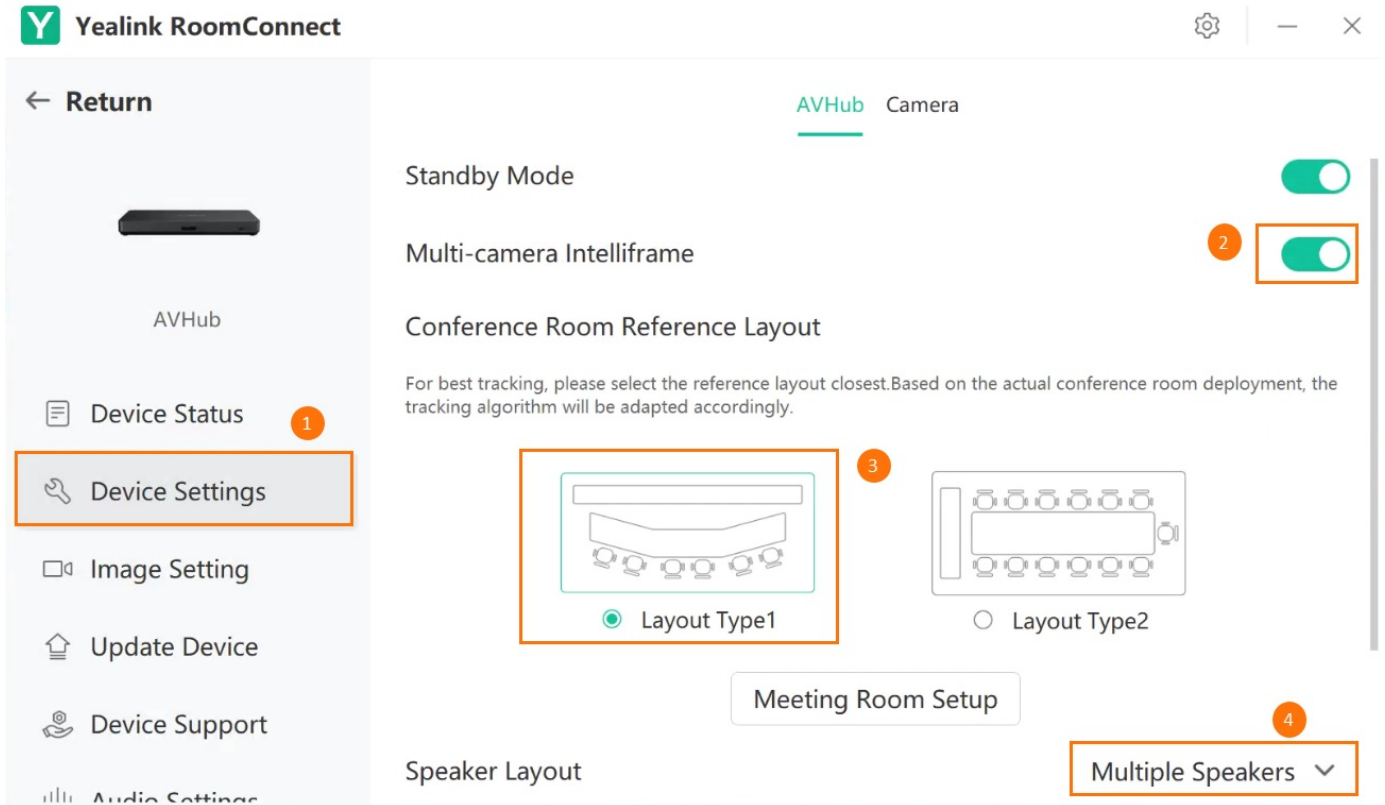

2. Select Room Control, drag and adjust the framing box to select the viewable area for voice tracking.

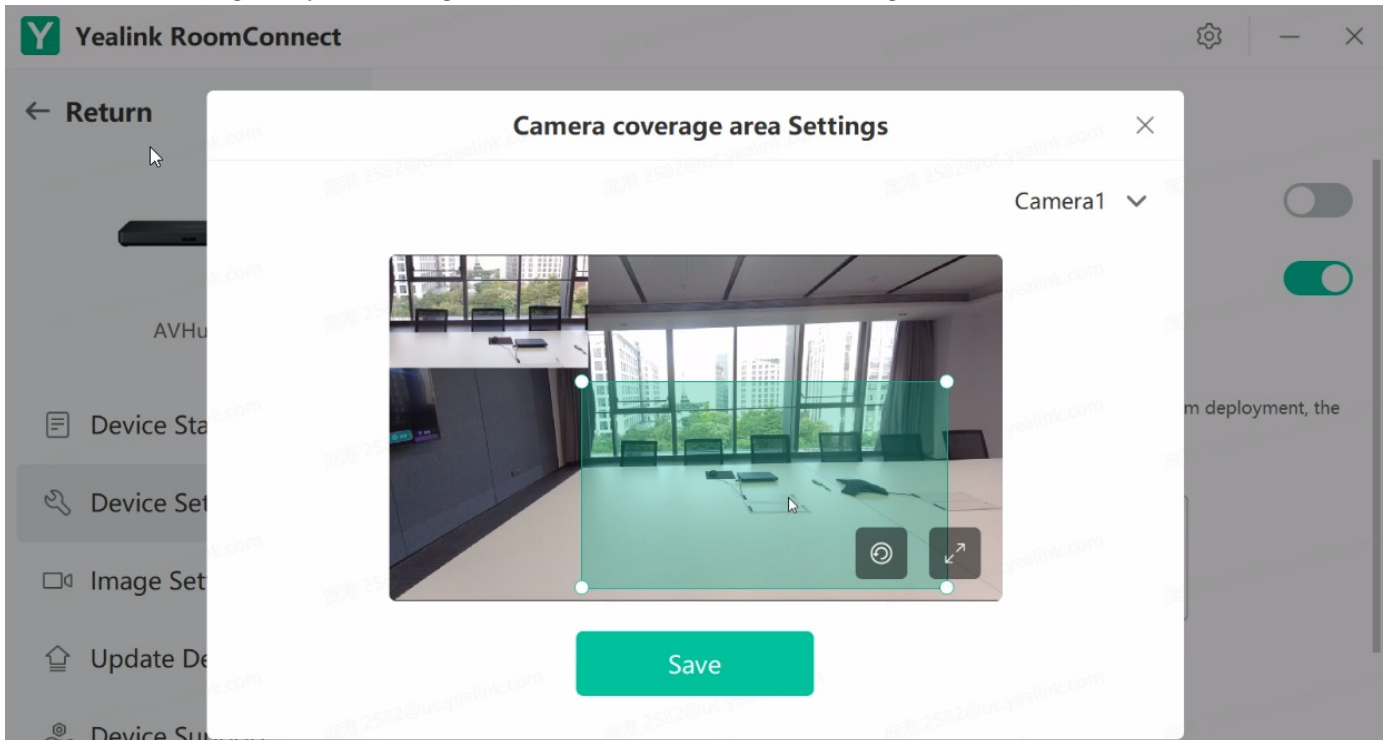

Layout Type 2:

Layout Type 2 is suitable for medium to large meeting rooms. When using this layout, you need to know the dimensions (length, width, and height) of your meeting room to utilize the multi-speaker tracking feature effectively.

Configuration Steps:

1. Measure the length, width, and height of the meeting room.
2. Deploy the devices on the walls according to deployment recommendations.

3. Enable AI Layout by selecting **AVHub > Device Settings > Conference Room Reference Layout > Layout Type 2 > Meeting Room Settings**. Click **image** to set the room's length and width.

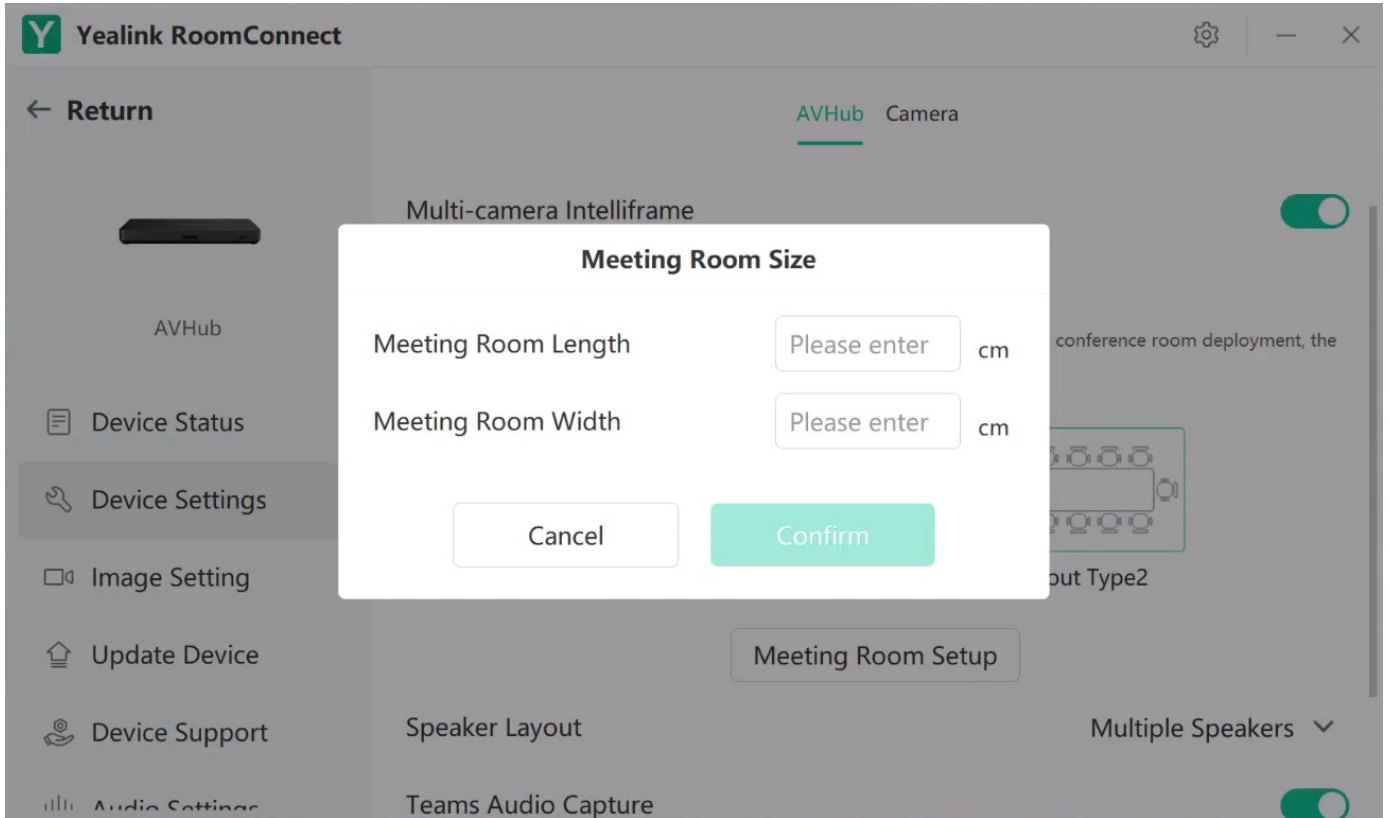

4. In the meeting room setup interface, you need to adjust the camera according to the actual room layout.

- Hold and drag the gray dot to move the camera's position.
- Click the gray dot to view detailed camera settings.
- Click the arrow > to enter camera settings.

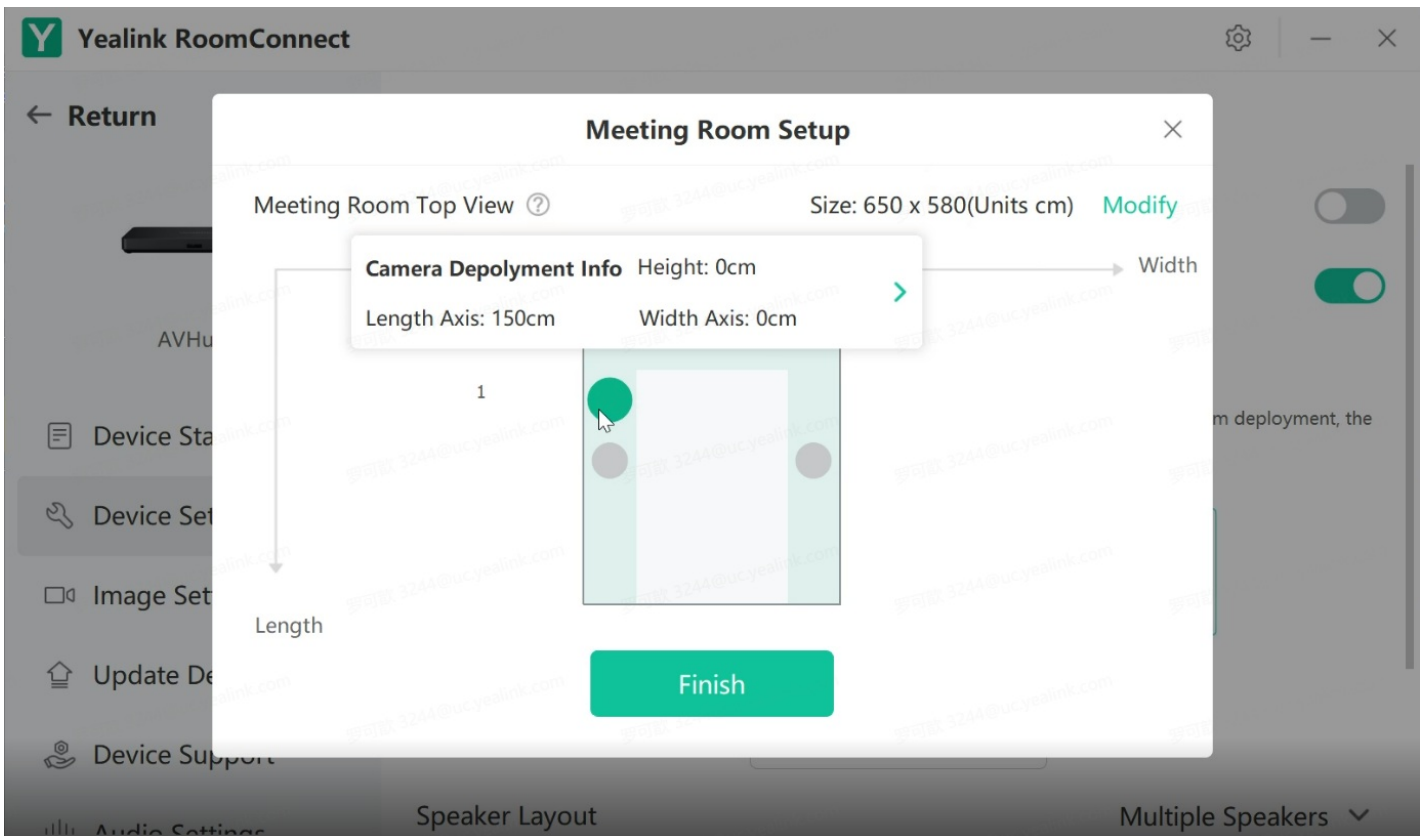

5. Adjust the camera presets and drag the box to select the area each camera needs to cover. For multiple cameras, please avoid overlapping coverage of the same seat, ensuring that there is no overlap in the voice tracking areas of each UVC camera.

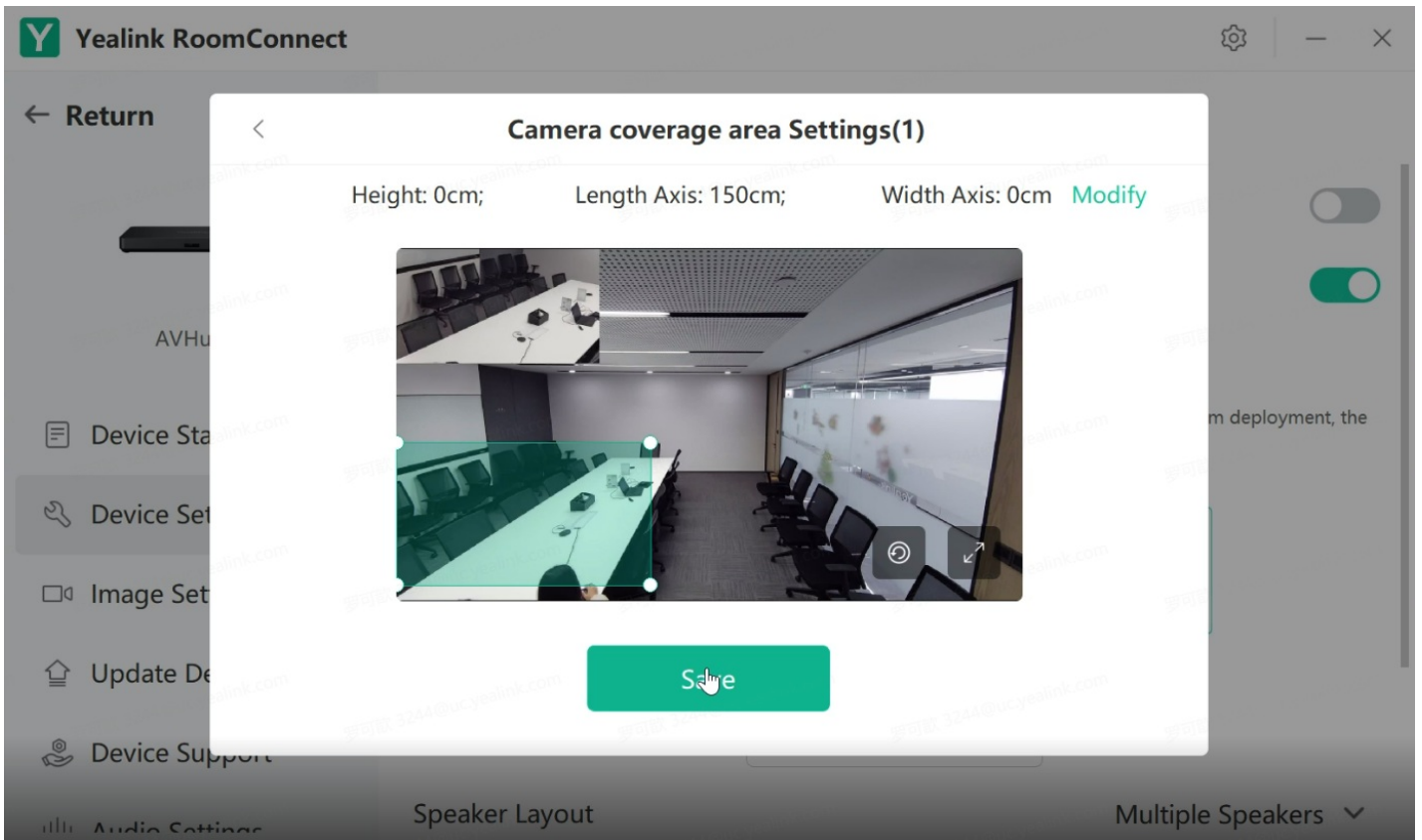

6. Click **Modify** to set the position of the UVC camera in the meeting room.

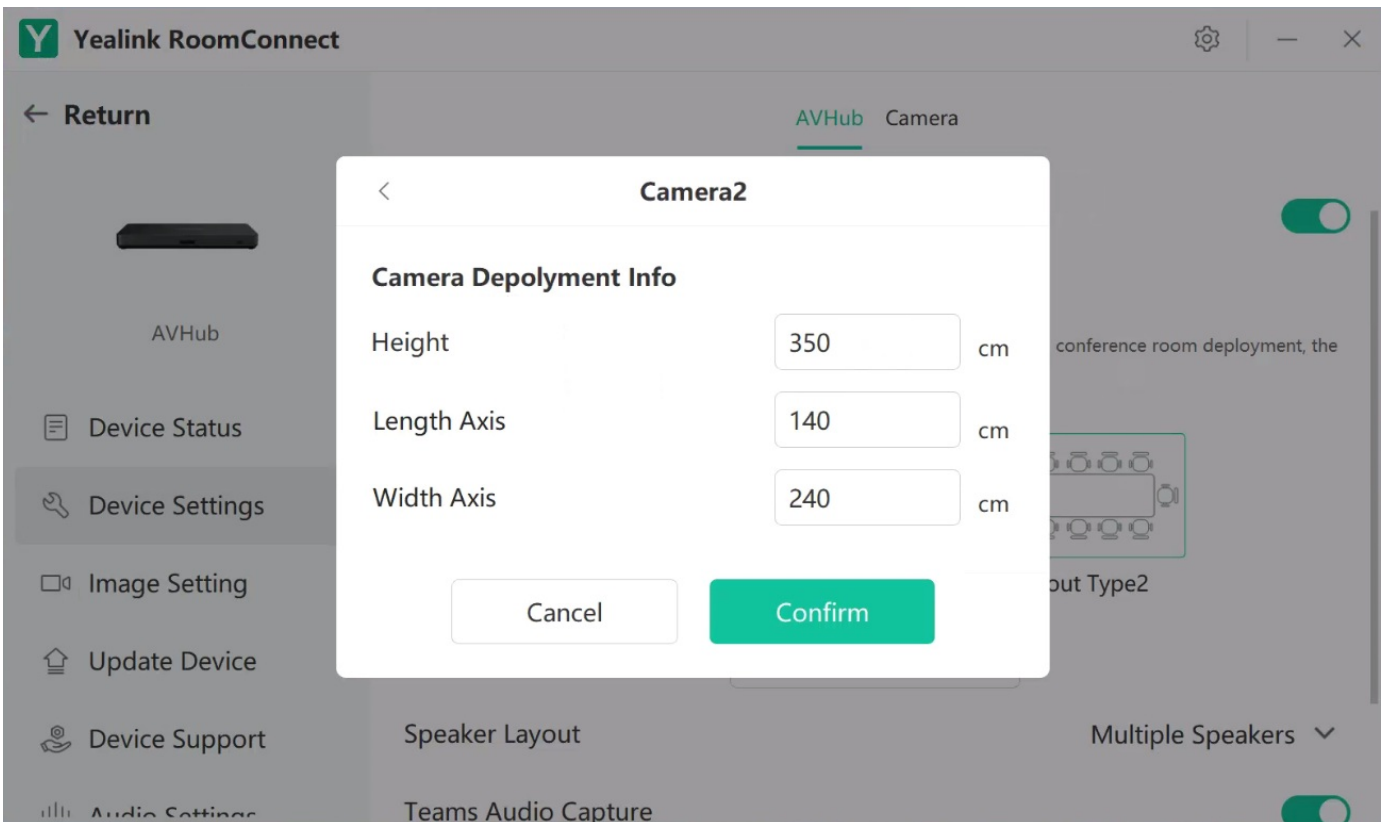

NOTE

1. The unit of measurement is cm/ft (you can change the unit of measurement in **Settings**).
2. Length, width, and height correspond to the measurements.

7. Click **Speaker Layout** to select your desired speaker mode.

Single Speaker Mode: Displays the current speaker.

Multi-Speaker Mode: Displays the most recent four speakers.

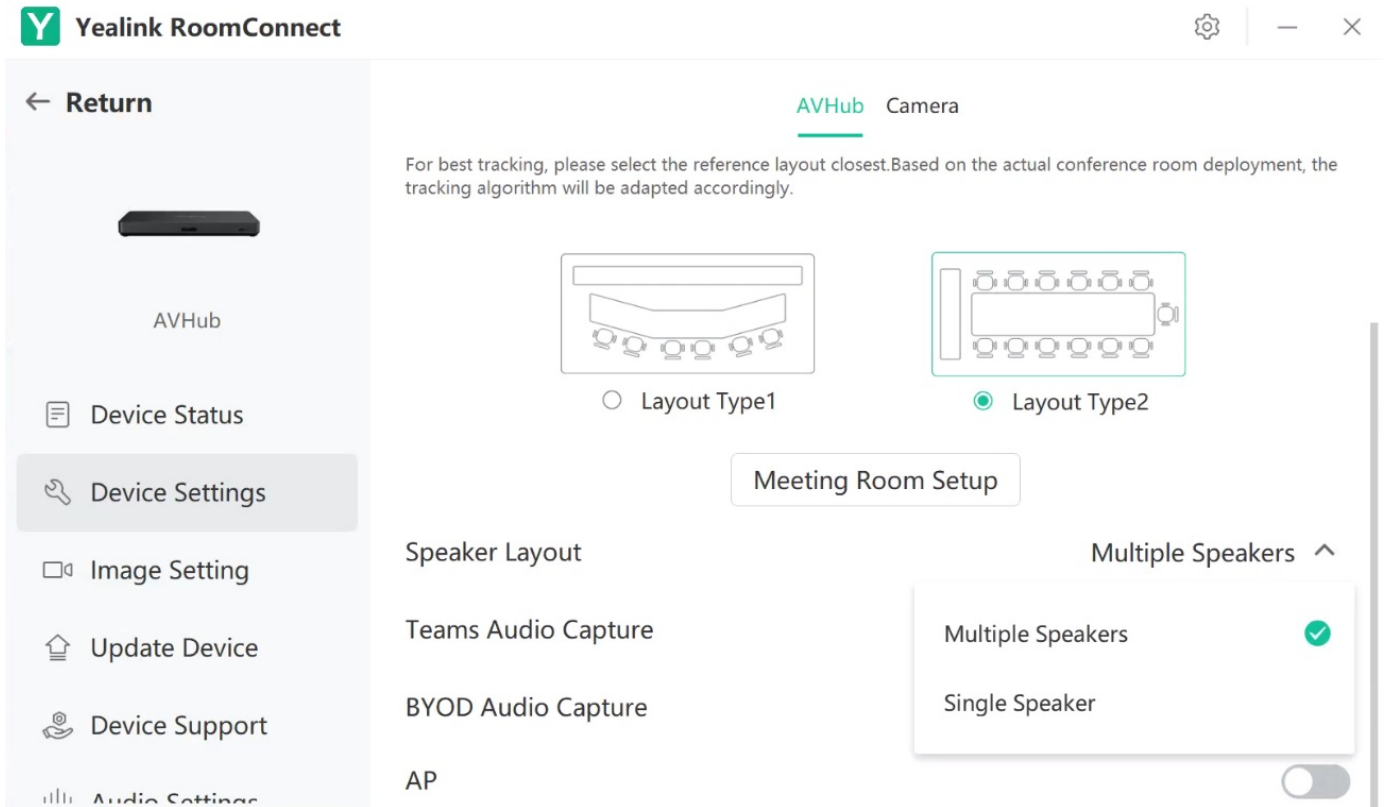

Attention

Please ensure that the UVC cameras are positioned accurately and avoid overlapping coverage between each camera in the same area.

Video Fence

Introduction

The UVC86 supports the video fence feature. After completing the conference room deployment, you can configure this feature through Yealink RoomConnect. The AI feature will detect and respond only to individuals within the video fence range, eliminating interference factors that could affect camera tracking stability, such as portraits hung on walls or reflections from glass surfaces, which enhances the efficiency of your meetings.

Before You Begin

- UVC86 is supported in 151.432.0.5 and later versions.
- Yealink RoomConnect is supported in 2.32.42.0 and later versions.

How to Use

1. You can directly use MTouch for operations or perform operations remotely. For remote management, please refer to [Remote Control](#).
2. Switch to **Windows mode**. For instructions on how to switch, please refer to [Switch Account](#).
3. Select **UVC86** on **Yealink RoomConnect**.

Enabled Feature

1. Click **UVC86 > Device Settings > Advanced Settings**.

Yealink RoomConnect

Return



UVC86



Device Status

Device Settings

Image Setting

Update Device

Device Support

Audio Settings

General Settings

Advanced Settings

Lens Calibration

Tracking Feature

Tracking Mode

Tracking Speed

>

>

>



Auto Framing

Fast

1

2

2. Click **Video Fence Settings**.

3. Enable the feature

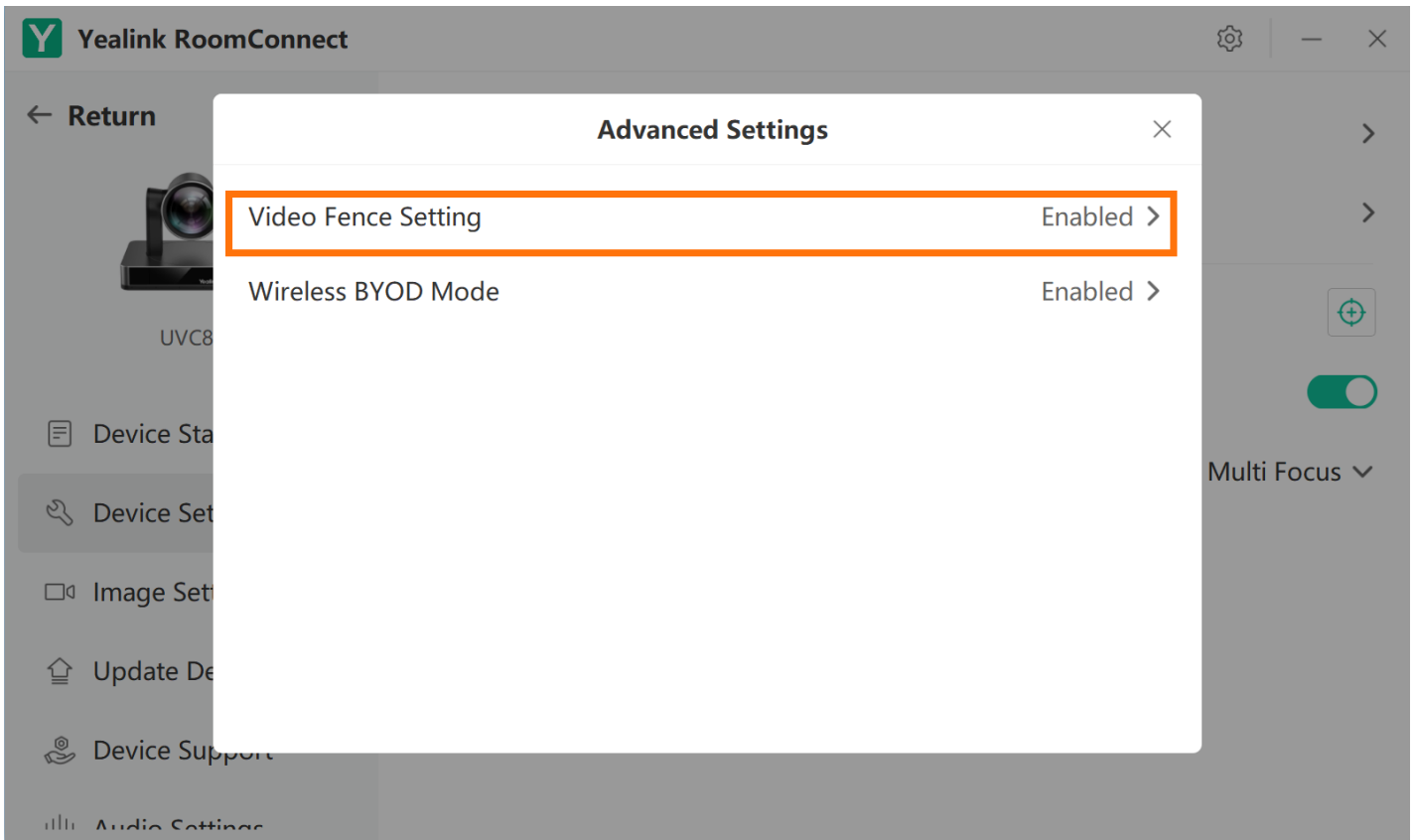
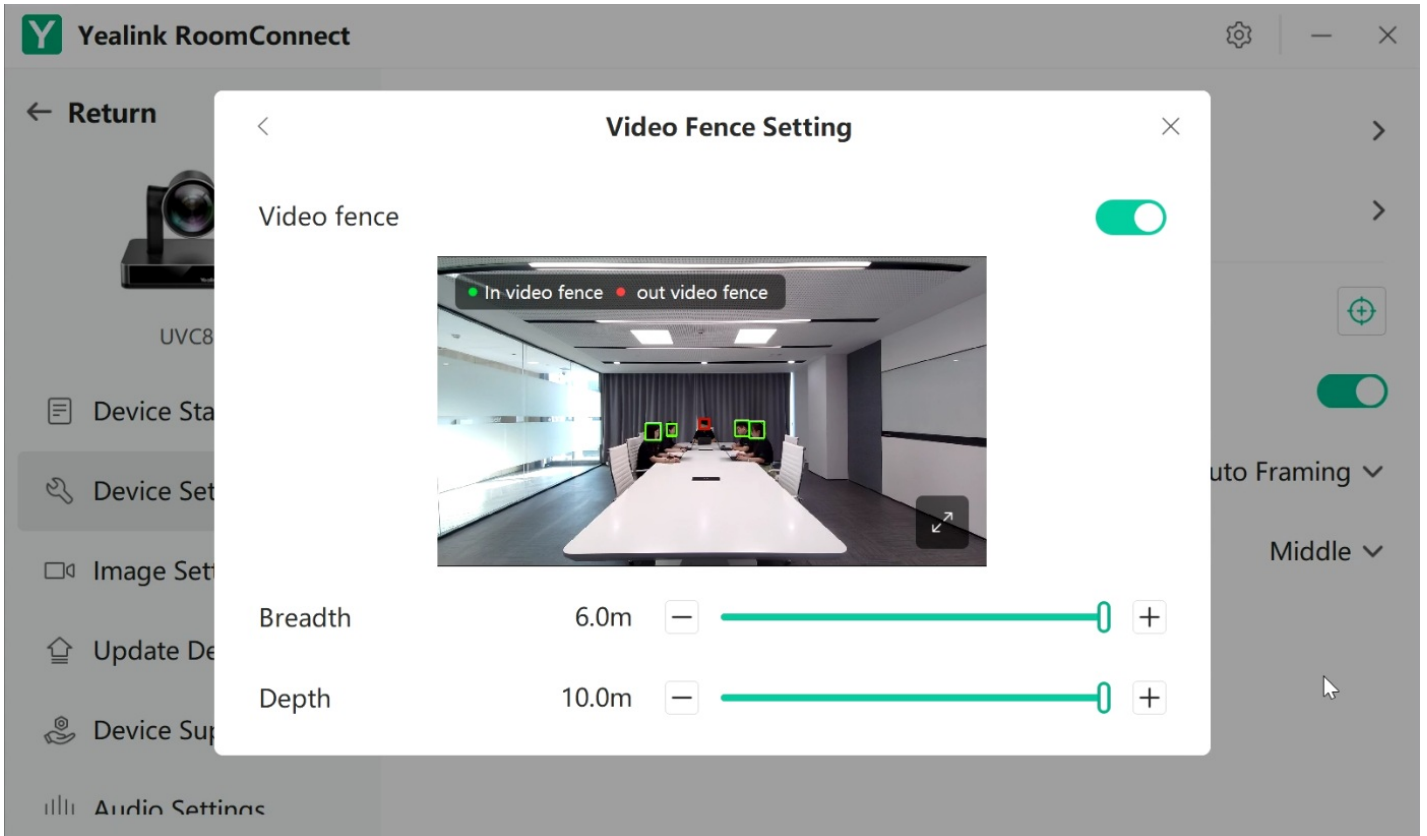

Image Preview

Click **Video Fence Settings** to enter Image Preview. The red outline indicates that the person in that position is outside the video fence range, while the green outline indicates that the person is within the video fence range. The camera will only respond to the actions of individuals within the green outline area.



Adjust the Breadth and Depth

The adjustable parameter range for the video fence is as follows:

Parameter	Range
Breadth	0-6 m/0-19.68ft
Depth	0-10 m/0-36.8ft

NOTE

1. You can go to **Setting > General Settings > Length Unit Setting** to adjust the length unit.
2. This feature can be used in conjunction with automatic framing, speaker tracking, and multi-focus mode. The presenter tracking mode is not affected during use.

AVHub Divisible Conference Room

Introduction

Divisible Room Mode is a solution designed for professional-grade meeting rooms. Professional-grade meeting rooms can be flexibly divided and combined. In typical scenarios, a professional meeting room can be divided into 2-4 separate spaces. Yealink innovatively utilizes AVHub with a switch to enable the ability to control space partitioning/merging in real time from the meeting control panel. In a divided state, each AVHub in individual meeting rooms plays a role in managing audio and video devices within that specific meeting room. In a merged state, one of the meeting rooms becomes the control room, overseeing all the audio and video devices within the combined meeting rooms. The AVHub devices in the merged rooms act as bridges for audio and video signal transmission. At this point, the interface for the divided meeting room will be locked, and the control room will gain control over all the peripherals in the merged rooms.

For the operation video, please refer to [Divisible Room](#).

Before You Begin

- Vision Required

AVHub is supported in 153.432.0.5 and later visions.

UVC86 is supported in 151.432.0.5 and later visions.

Yealink RoomConnect is supported in 2.32.42.0 and later visions.

- For an entire divisible space, the maximum total number of audio and video devices that the MVC system can support must meet the requirements outlined in the following table:

Name of Audio and Video Devices	Maximum Supported Number of Devices
UVC84/UVC86	9
VCM34	8
VCM35	8
VCM38	8
MSpeaker II	4

Connect multiple MVC systems' AVHubs using Ethernet cables, as shown in the deployment diagram below:

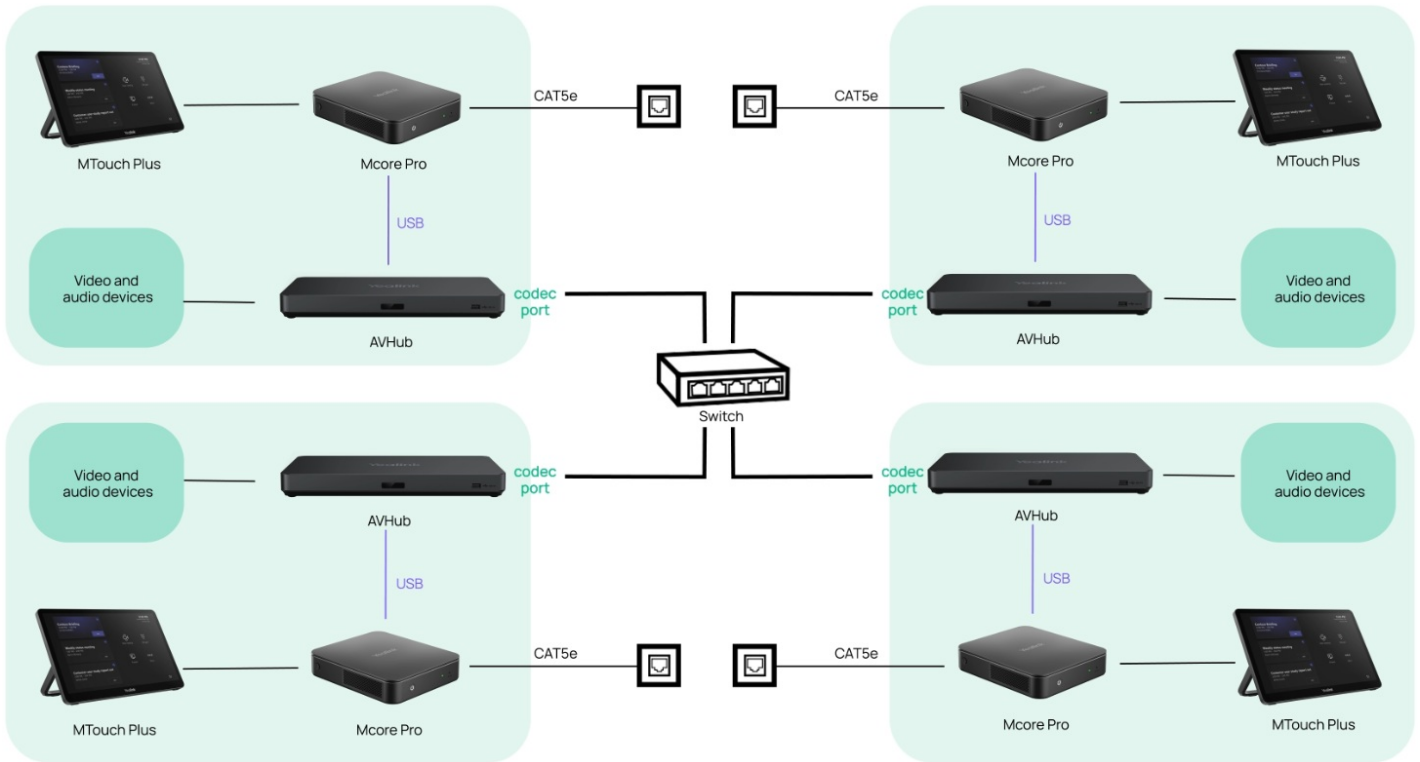

NOTE

1. If you need to merge more than two conference rooms, you should connect all the AVHubs' Codec interfaces from the rooms using Ethernet cables to the same switch (the switch should not be connected to the external network), and the switch should be a Gigabit switch.
2. Mcore Pro needs to be on the same local area network (LAN).
3. Conference room peripherals like cameras and microphones should be connected to AVHub via Ethernet cables and should not be connected to Mcore Pro via USB. Merging conference rooms means merging the devices under AVHub, and peripherals connected to Mcore Pro cannot be merged.
4. All conference rooms that need to participate in the merger must enable the divisible conference room feature, or they cannot be interconnected.
5. Before connecting to AVHub, you need to enable the divisible conference room feature on AVHub.

How to Use

You can operate the system directly using the MTouch II provided with the MVC series, or you can access the device management platform for remote operation. For remote management instructions, please refer to [Remote Control](#).

In the divisible mode, the status of the devices connected to the MVC is as shown in the picture below:

NOTE

Here is an example using two sets of MVC devices, and the logic and operations remain the same for more than two sets.

AVHub-1(before enable Divisible Room)

Yealink RoomConnect

Device Name	Image	Configuration Details
AVHub		Bind camera: 4 Firmware Version: 153.431.0.5 Hardware Version: 153.0.16.0.0.0.0 Serial Number: 8703018090000098
VCM35		Quantity: 2 Firmware Version: 98.431.0.5 Hardware Version: 154.16.0.0.0.0.0
MTouchII		Firmware Version: 126.424.0.25 Hardware Version: 126.0.0.0.0.0.0 Serial Number: 803061C080002459
MSpeakerII		Firmware Version: 98.431.0.15 Hardware Version: 98.3.0.0.2.0.32 Serial Number: 806051D120000073

Windows taskbar: Type here to search, 14°C 晴朗, 7:38 PM 2/7/2023

AVHub-2(before enable Divisible Room)

Yealink RoomConnect

Device Name	Image	Configuration Details
AVHub		Bind camera: 5 Firmware Version: 153.431.0.5 Hardware Version: 153.0.33.0.2.0.32 Serial Number: 806011E080000077
VCM35		Quantity: 2 Firmware Version: 98.431.0.5 Hardware Version: 154.16.0.0.0.0.0
MTouchII		Firmware Version: 126.424.0.15 Hardware Version: 126.2.0.0.2.0.17 Serial Number: 803061E070001623
MSpeakerII		Quantity: 3 Firmware Version: 98.431.0.15 Hardware Version: 98.3.0.0.1.0.0

Windows taskbar: Search, 今日热点, 7:49 PM

Method 1: Configure via Yealink RoomConnect

Taking AVHub-1 as the “main control room” as an example. Open AVHub in the Yealink RoomConnect.

1. Click **Divisible Room**.
2. Click enabled.

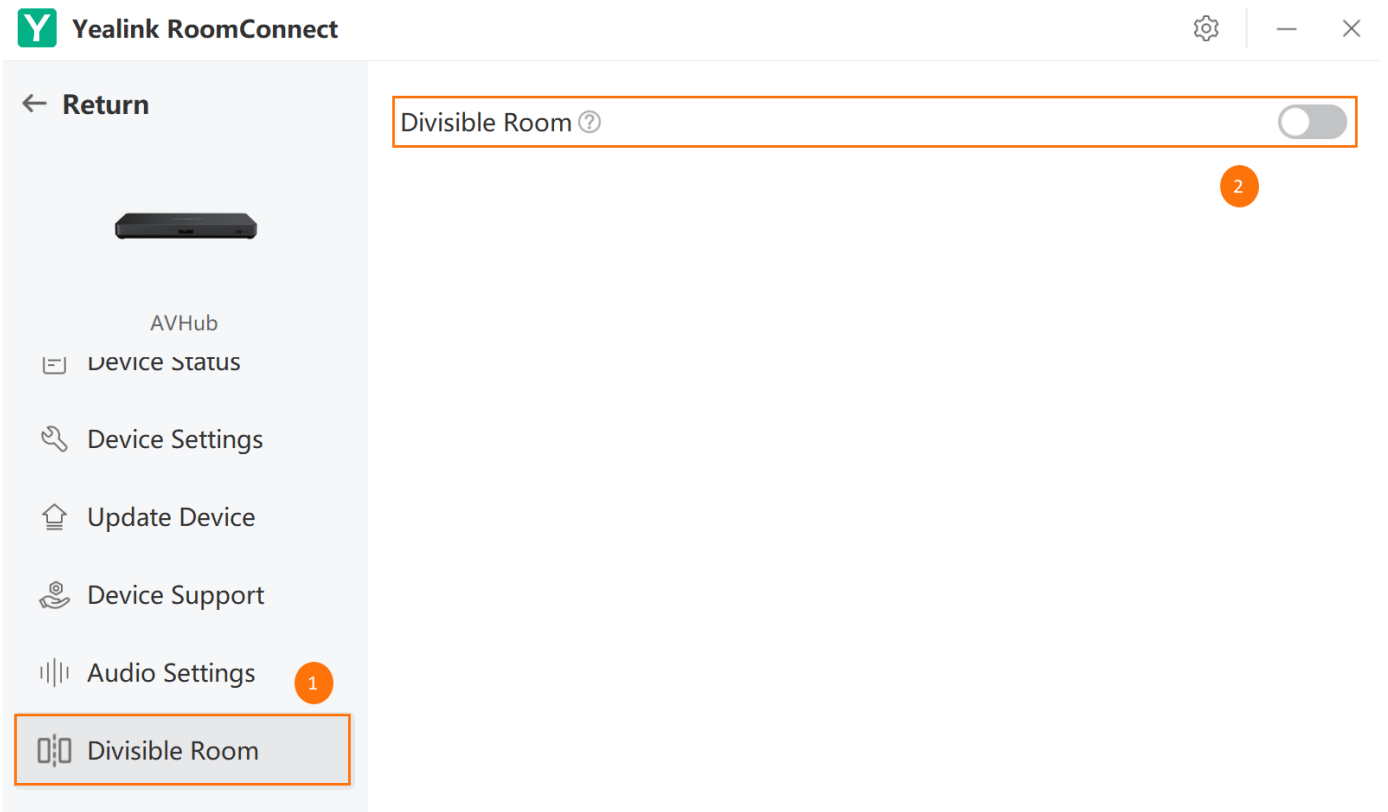

3. Click the **Add/Remove** button to add conference rooms. You can also manually add conference rooms by entering the IP address of Mcore Pro.

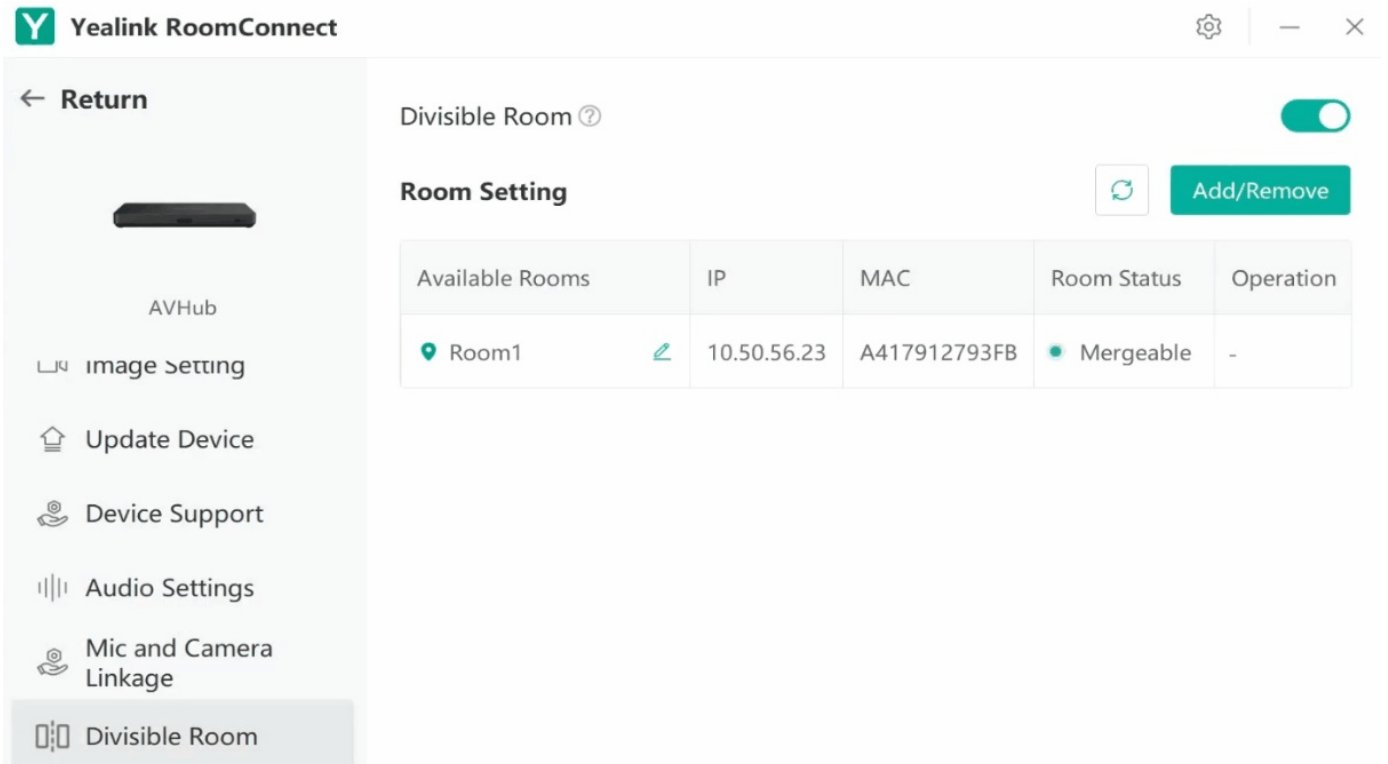

- You can also manually add conference rooms by entering the IP address of Mcore Pro.

Yealink RoomConnect

← Return

AVHub

Image Setting

Update Device

Device Support

Audio Settings

Mic and Camera Linkage

Divisible Room

Divisible Room

Room Setting Refresh Add/Remove

Available Rooms	IP	MAC	Room Status	Operation
Room1	10.50.56.23	A417912793FB	Mergeable	-
Room3	10.50.56.17	A417912795DC	Mergeable	Merge
room4	10.50.56.25	A41791285998	Mergeable	Merge
room2	10.50.56.30	A417912680A6	Mergeable	Merge

- After merging the conference rooms, the Control Room will gain control over all peripherals connected to the AVHubs in the merged rooms, and they will be centrally managed on AVHub-1.

AVHub-1(after becoming the control room)

Yealink RoomConnect

AVHub

Bind camera: 9

Firmware Version: 153.431.0.5

Hardware Version: 153.0.33.0.2.0.32

Serial Number: 806011E080000077

VCM35

Quantity: 4

Firmware Version: 98.431.0.5

Hardware Version: 154.16.0.0.0.0.0

MTouchII

Firmware Version: 126.424.0.15

Hardware Version: 126.2.0.0.2.0.17

Serial Number: 803061E070001623

MSpeakerII

Quantity: 4

Firmware Version: 98.431.0.15

Hardware Version: 98.3.0.0.1.0.0

Search 14°C 晴朗 7:47 PM

- AVHub-1(the interface of control room)

Yealink RoomConnect

← Return

AVHub

- Image Setting
- Update Device
- Device Support
- Audio Settings
- Mic and Camera Linkage
- Divisible Room**

Divisible Room

Room Setting Refresh Add/Remove

Available Rooms	IP	MAC	Room Status	Operation
Room	10.50.67.56	A417912793FB	Control Room	Unmerge all
Test03Room	10.50.67.50	A417912795DC	Merged	Unmerge

- AVHub-2(after merging)

Yealink RoomConnect

AVHub

Bind camera: 0

Firmware Version: 153.431.0.5

Hardware Version: 153.0.16.0.0.0.0

Serial Number: 8703018090000098

MTouchII

Firmware Version: 126.424.0.25

Hardware Version: 126.0.0.0.0.0.0

Serial Number: 803061C080002459

Method 2: Configure Under Skype Mode

1. On the MTouch II of the control room, switch to Skype account mode, go to **Room Control > Divide Meeting Rooms**, and enter the admin password (default: admin). When meeting rooms are not merged, the MVC system operates independently. Click **Merge**, and the peripherals under the AVHub of the corresponding meeting room will disconnect and restart.

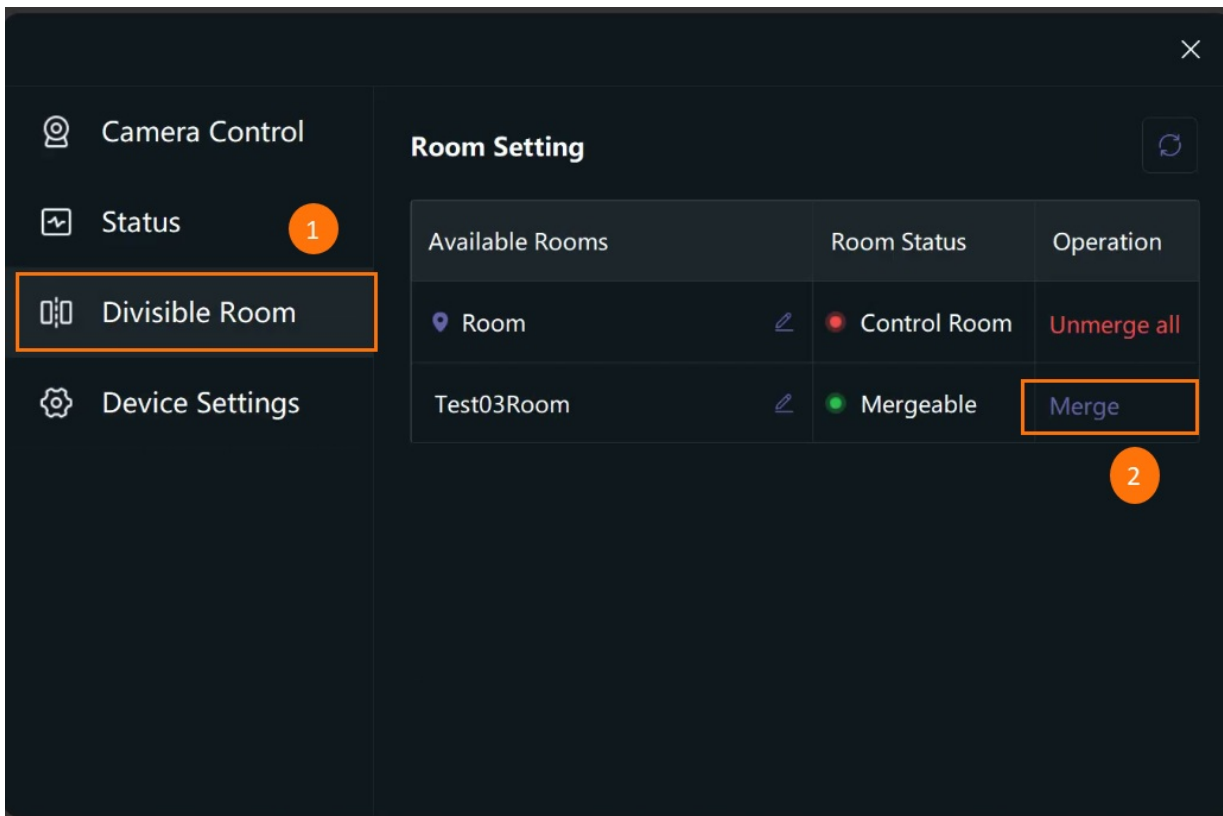
**NOTE**

1. Before proceeding with the meeting room merge operation, ensure that all meeting rooms participating in the merge have enabled the Divisible Meeting Room feature.
2. The merged meeting rooms need to be added to the room settings list in Yealink RoomConnect. For specific setup methods, please refer to [setting up via YRC](#)

- After the peripherals in the merged rooms have successfully restarted, the AVHub of the merged room will automatically reconnect. If you switch to Yealink RoomConnect at this point, you can see that the AVHub in the merged room is being used as a switch with a bound audio-video device count of 0. The AVHub in the control room binds all audio-video devices, and the YRC display is the same as when set up through YRC. In Skype mode, the divisible room interface will also refresh to the merged state, and you can directly view the roles and current status of each room.

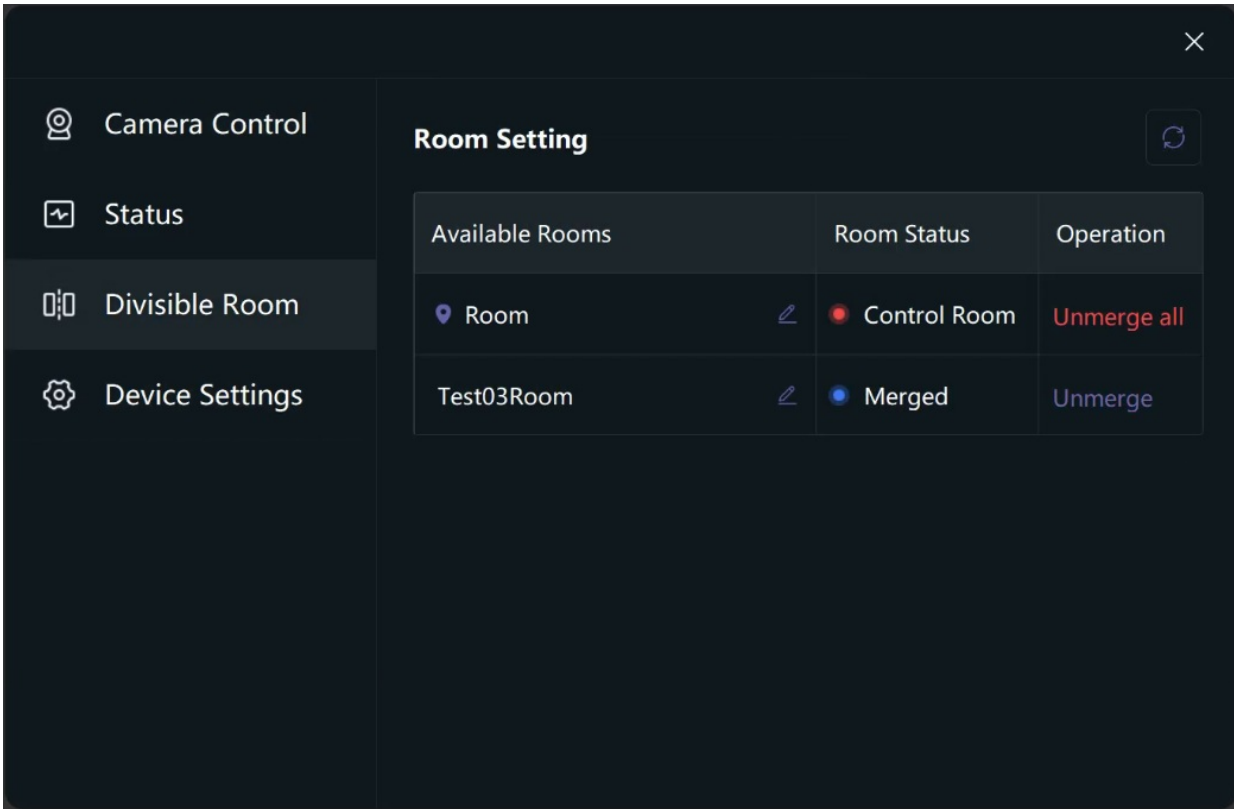

The interface of a divisible room of the merged rooms is locked and cannot be operated.

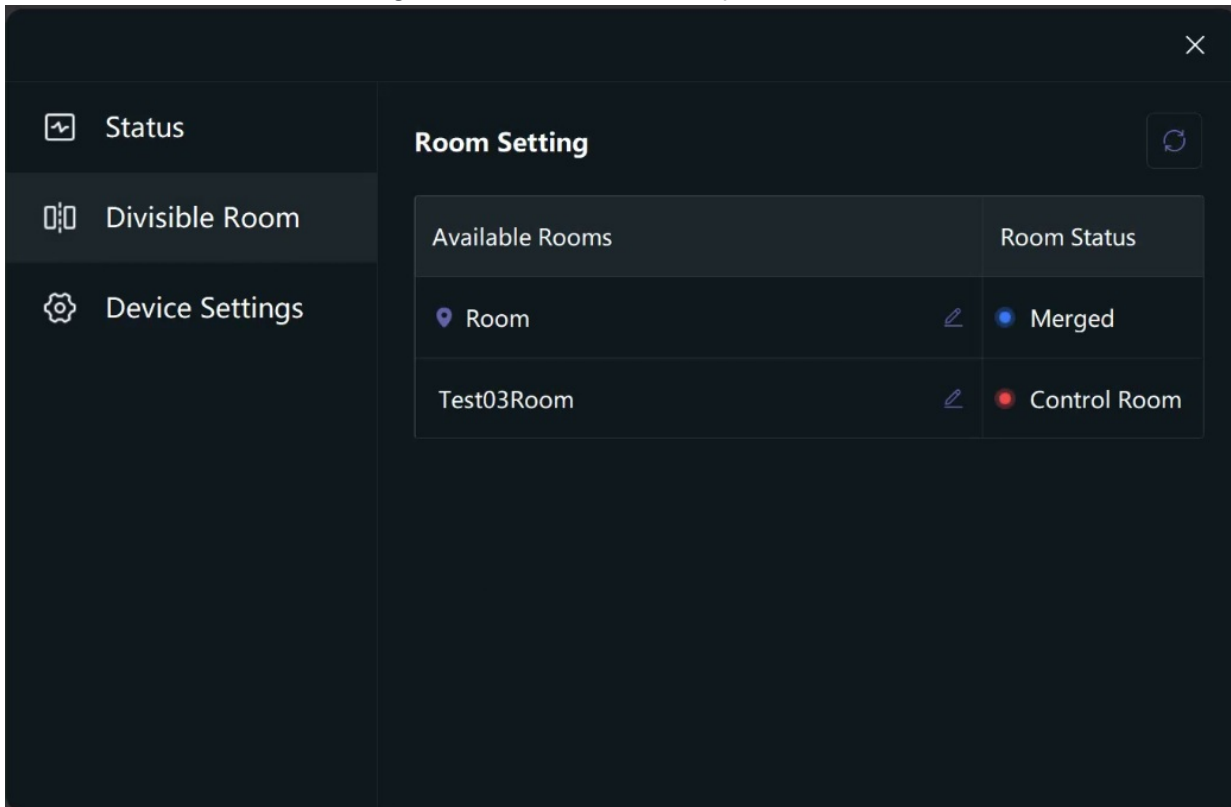

Rename Room Name

You can customize the name of the meeting room for better management. Click the edit icon to rename it. Once modified, the displayed name in the

interface of the merged rooms will automatically update. Here are the steps:

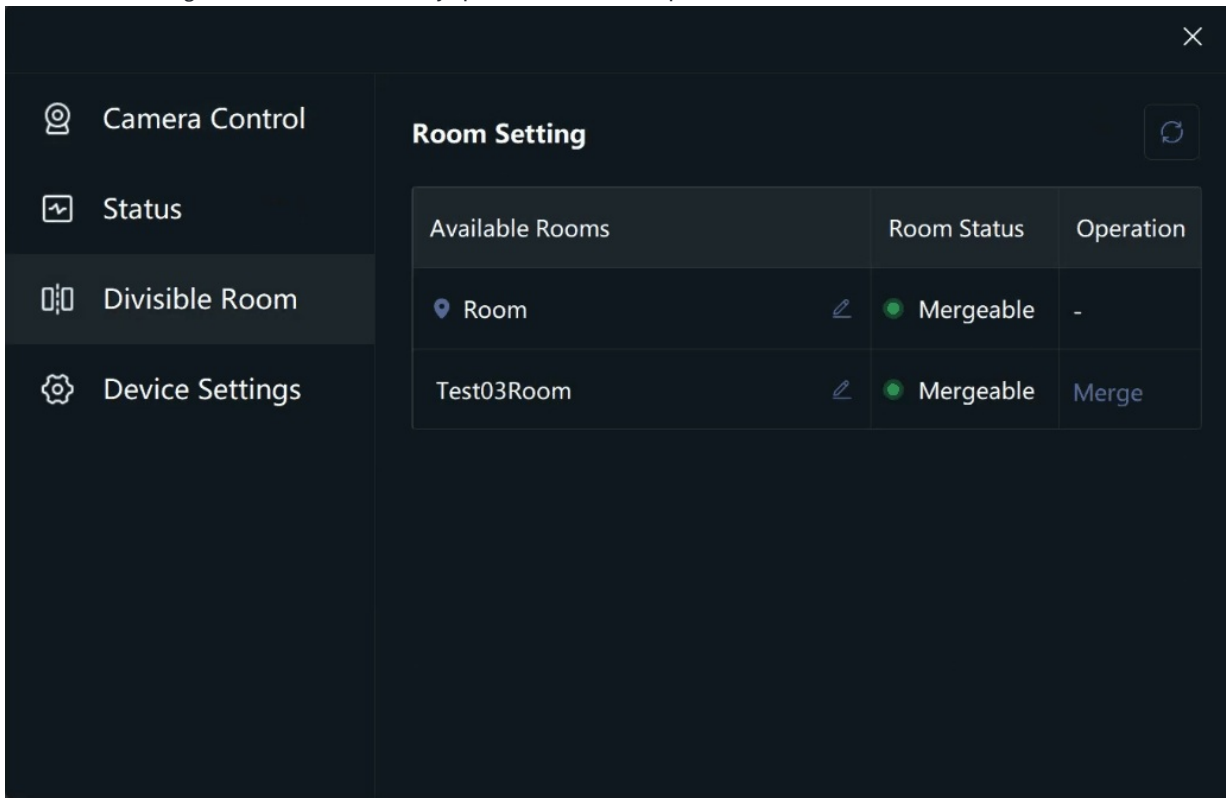

Exit the Divisible Room Mode

Method 1: exit via Yealink RoomConnect.

1. Click **Divisible Room** of the AVHub in the control room.
2. Click **Unmerge**.
3. Confirm the action by clicking Confirm.

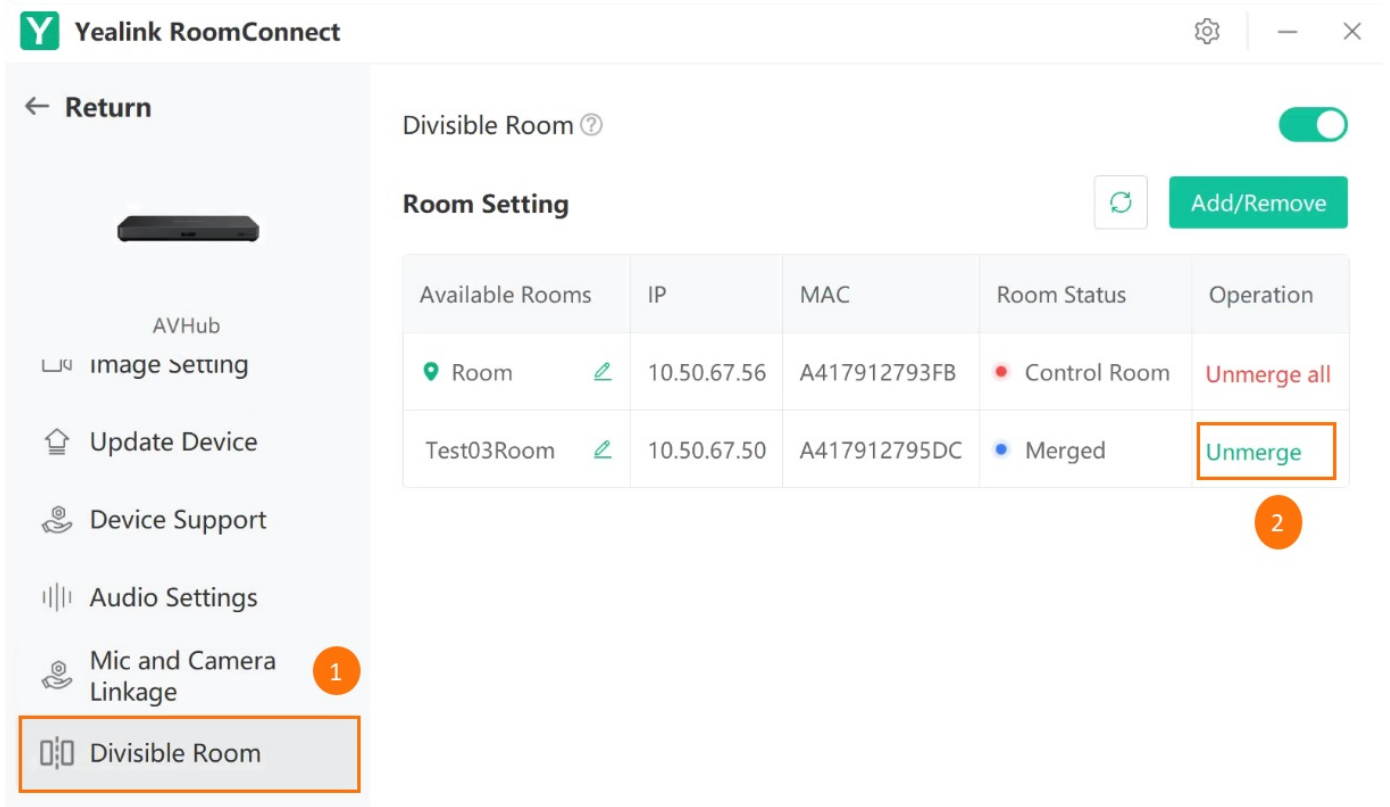

Method 2: exit via Skype.

1. On the MTouch II of the control room, switch to Skype account mode.
2. Go to **Room Control > Divide Meeting Rooms**, and enter the admin password (default: admin). When meeting rooms are not merged, the MVC system operates independently.
3. Click **Unmerge**, and a confirmation dialog will appear.
4. Confirm the action by clicking **Confirm**. The peripherals under the AVHub of the corresponding meeting room will disconnect and restart.

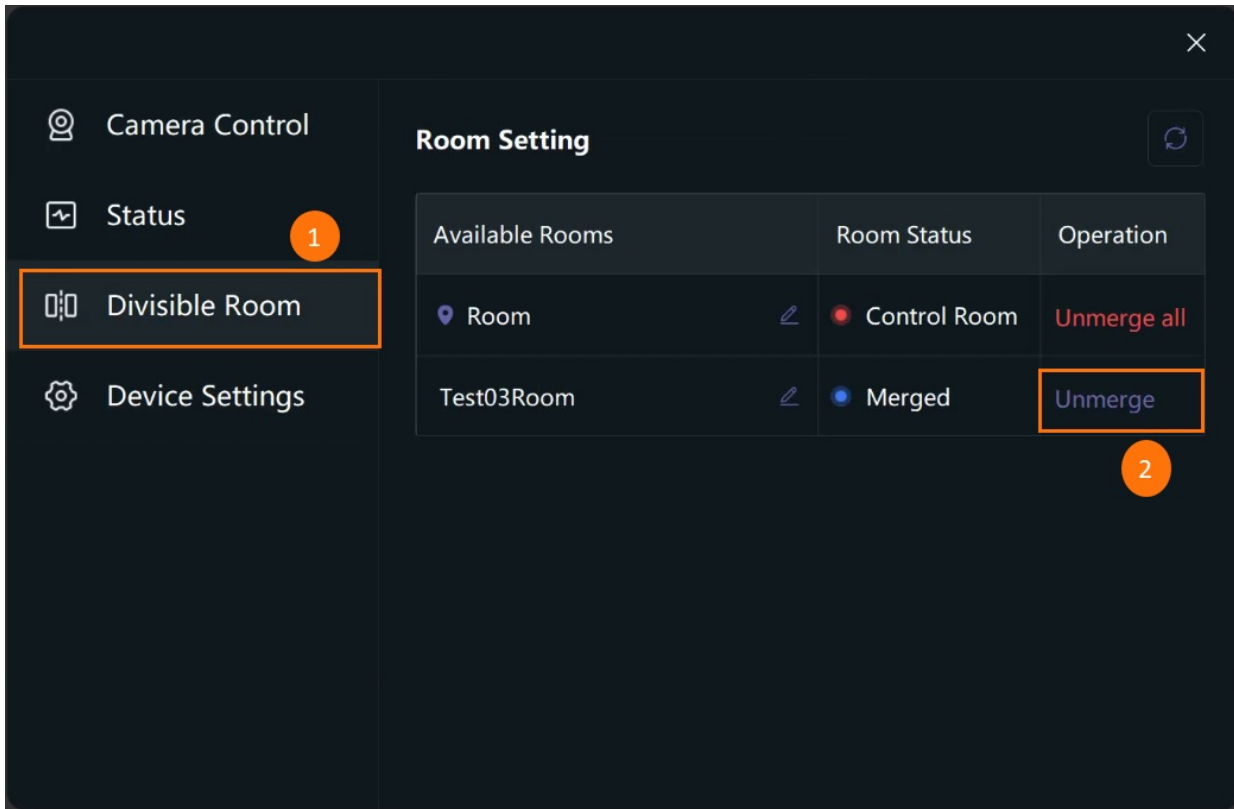
**Modify Password**

To modify the manager password in Skype mode while using the divisible feature, follow these steps:

1. Click the settings icon  on Yealink RoomConnect (YRC), .

2. Select **Advanced Settings > Set Manager Password > Modify Password**.

The screenshot displays the Yealink RoomConnect management interface. At the top left is the Yealink logo and 'RoomConnect' text. At the top right are settings, minimize, and close icons. The main area contains four device status cards:

- AVHub**: Bind camera: 1, Firmware Version: 153.432.254.144, Hardware Version: 153.0.33.0.2.0.32, Serial Number: 806011F070000948.
- VCM35**: Firmware Version: 98.432.254.34, Hardware Version: 154.16.0.0.0.0.0 (with a refresh icon), Serial Number: 803144F050101149.
- MTouch Plus**: Firmware Version: 282.410.254.254, Hardware Version: 282.0.0.0.0.0.0, Serial Number: 806022F060001204.
- MSpeakerII**: Firmware Version: 98.432.254.14, Hardware Version: 98.3.0.0.2.0.32, Serial Number: 806051F030000972.

Attention

1. When AVHubs connected to the same switch have already selected a room as the control room, other rooms can only choose to be merged or split. In other words, there can only be one control room under the same switch.
2. Room statuses include mergeable, control room, merged, and offline. Offline rooms cannot undergo room merging or splitting operations.
3. If the control room's host is restored to factory settings or the split room function is disabled, the merge will be dissolved directly. If the host of the merged room is restored to factory settings or the split room function is disabled, it will detach itself from the merge.
4. Restarting the host, power outages, or network fluctuations in the control room will not affect the statuses of other rooms.

Audio Setting

Separate Microphone Mute Control

Introduction

If you use multiple microphones (VCM34/VCM38/CPW90-BT) in the meeting and the microphones are far away, you can mute one of the desired microphones separately.

How to Use

- You can directly use the MTouch II matched with MVC to operate or log in to the Yealink Device Management Platform to operate remotely. For remote information, please refer to [Remote Control](#).
- This feature is only applicable to UVC84 (firmware version: 262.424.0.5.rom or later)/UVC86 camera (firmware version: 151.424.0.5.rom or later).

You need to cascade multiple microphones to the UVC84/UVC86 camera.

1. Enable Mute Control in Yealink RoomConnect

You need to switch the system to **Windows Mode** (For more information, please refer to [Switch Account](#)).

1. Open the Yealink RoomConnect application and select the camera card.
2. Select **Audio Settings**.
3. Enable **Separate Microphone Mute Control**.

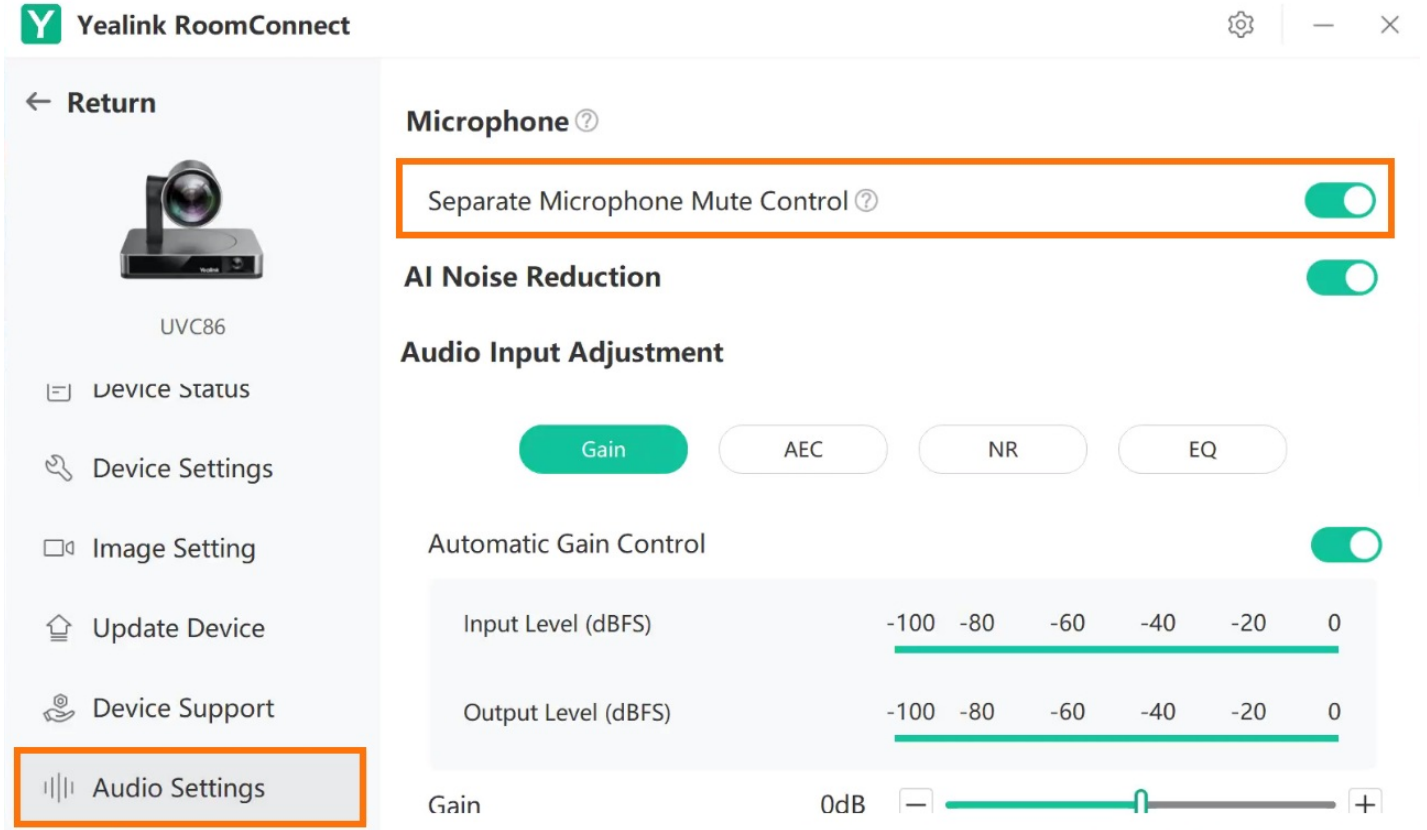

2. Enable Mute Control in Microsoft Teams Rooms



When you are not in the meeting:

1. Select **Room Controls** to go to **Mic Control**.
2. Select **Find Mic** to find the corresponding microphone. The microphone you are searching for will flash red and green alternatively.

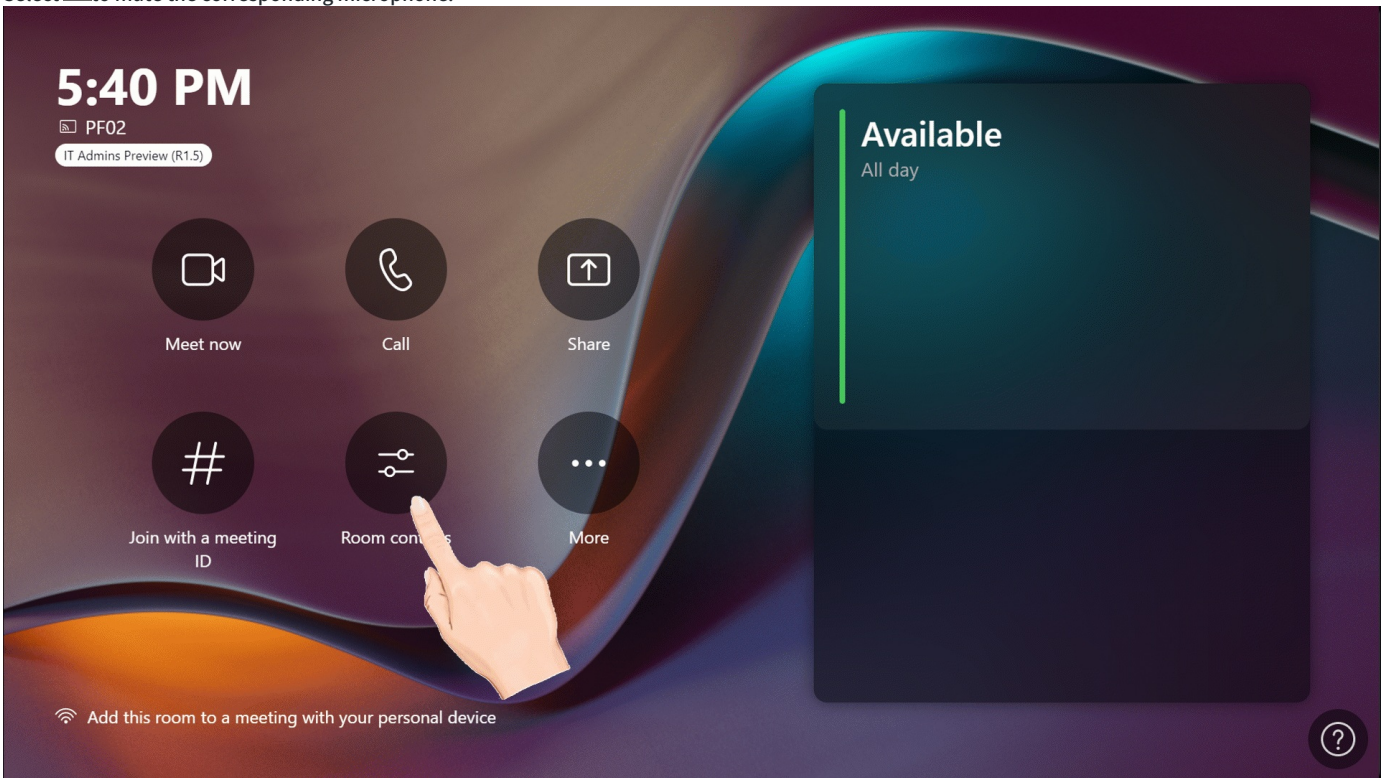
3. Select  to mute the corresponding microphone.



When you are in the meeting:

1. Select  **Room Controls** to go to **Mic Control** page.
2. Select **Find Mic** to find the corresponding microphone. The microphone you are searching for will flash red and green alternatively.
3. Select  to mute the corresponding microphone.

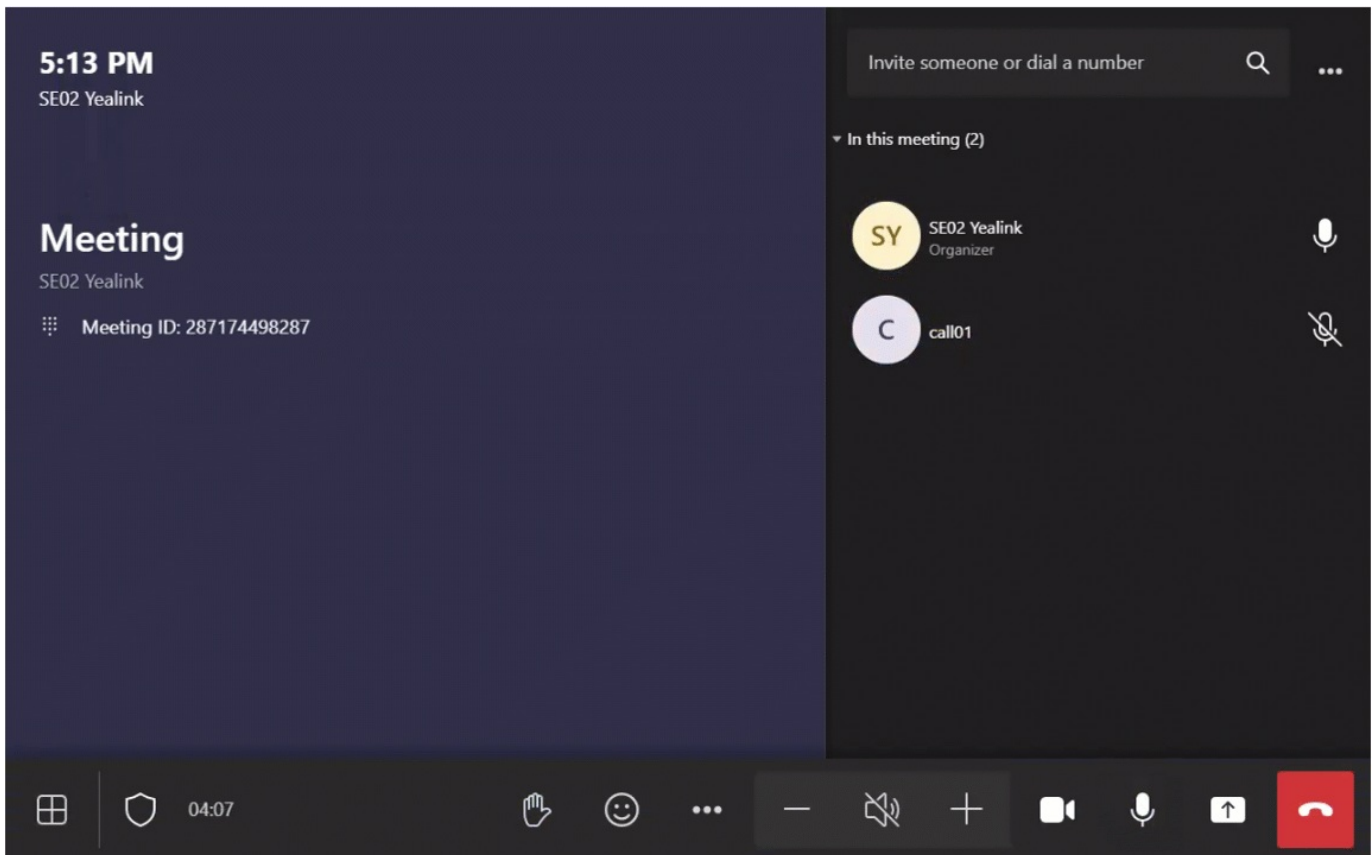



Rename Microphone

Introduction

After enabling the [Separate Microphone Mute Control](#), you can also rename the microphone to distinguish different microphones better.



How to Use

When you are not in the meeting:

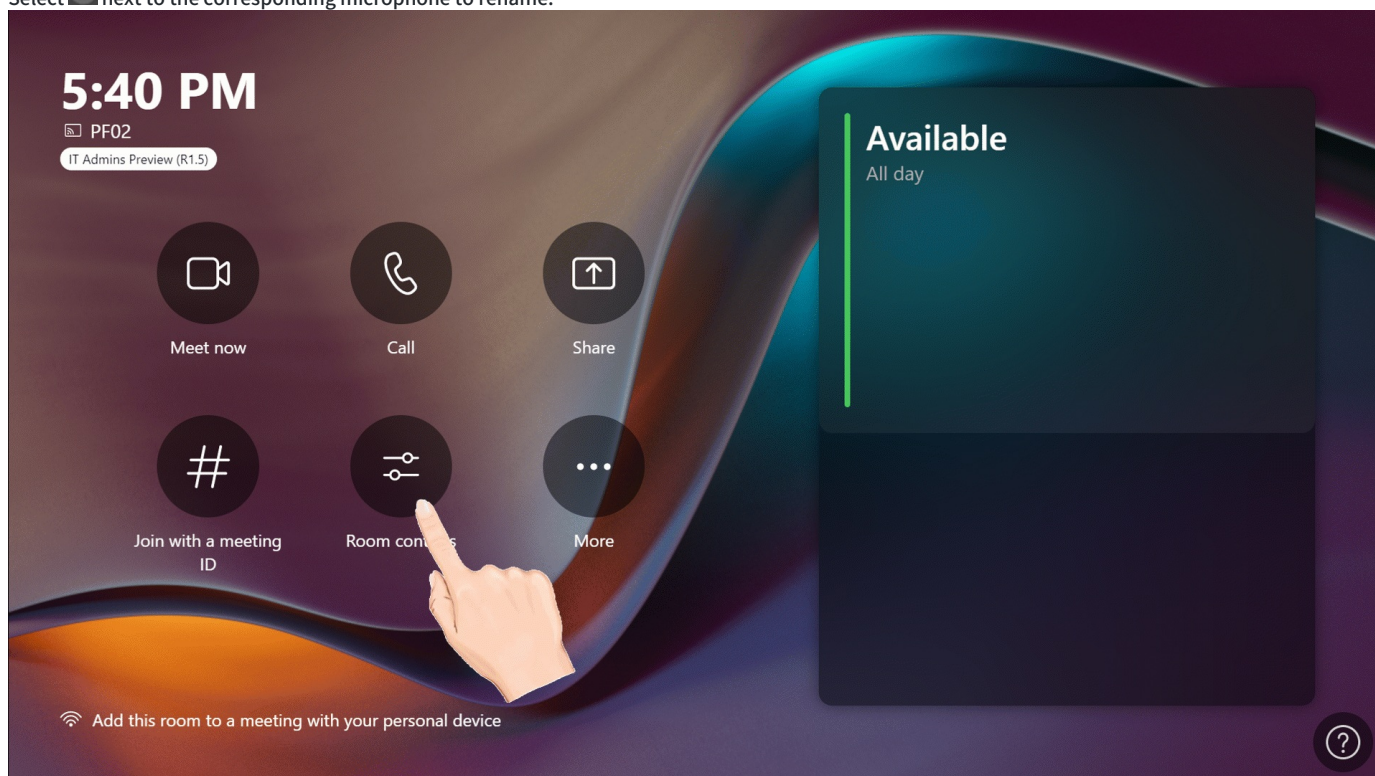
1. Select  to go to **Mic Control** page.
2. Select  next to the corresponding microphone to rename.



When you are in the meeting:

1. Go to  > **Room Controls** to enter **Mic Control** page.
2. Select  next to the corresponding microphone to rename.

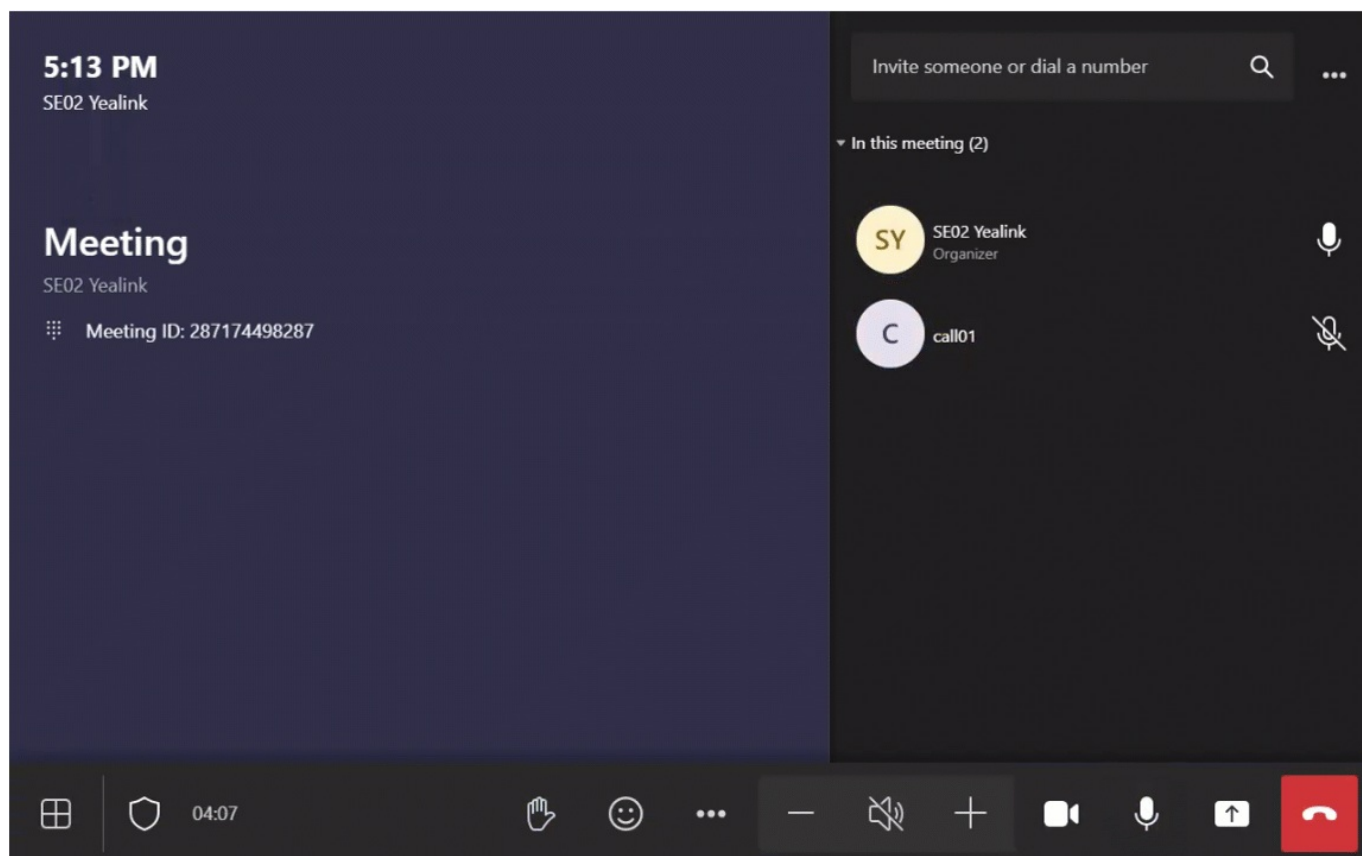

FAQ

I can't find the Microphone Control to rename the microphone. Can not rename microphones?

You need to enable [Separate Microphone Mute Control](#) in the Yealink RoomConnect.

Audio Settings

Introduction

You can set up the microphone and speaker used in the meeting in advance.

How to Use

1. You need to switch the system to Microsoft Teams mode (For more information, please refer to [Switch Account](#)).
2. Go to **More > Settings** to enter the administrator password (default: sfb).
3. Select **Peripherals**.

4. Set individual audio devices and speaker volume:

The microphone for the meeting:

- Microphone (Yealink MTouch II /Plus Headset Audio): The device is connected to the headset port of MTouch II /Plus.
- Microphone (Yealink MTouch II /Plus Screen Capture): MTouch II /Plus screen capture.
- Acoustic Echo Canceling Microphone: The microphone device is connected to the UVC camera/AVHub.

The speaker for the meeting:

- Microphone (Yealink MTouch II /Plus Headset Audio): The device is connected to the headset port of MTouch II /Plus.
- Acoustic Echo Canceling Microphone: The microphone device is connected to the UVC camera/AVHub.

The default speaker:

- Microphone (Yealink MTouch II /Plus Headset Audio): The device is connected to the headset port of MTouch II /Plus.
- Acoustic Echo Canceling Microphone: The microphone device is connected to the UVC camera/AVHub.

NOTE

Only the higher-prior microphone will take effect if your UVC camera/AVHub is connected to multiple microphones simultaneously. Microphone priority: VCM38 > VCM35 > VCM34 > VCM36-W > CPW90/CPW90-BT/CPW65 > Line-In > Built-in microphone > USB to Line-In.

3. Select **Save and exit**.

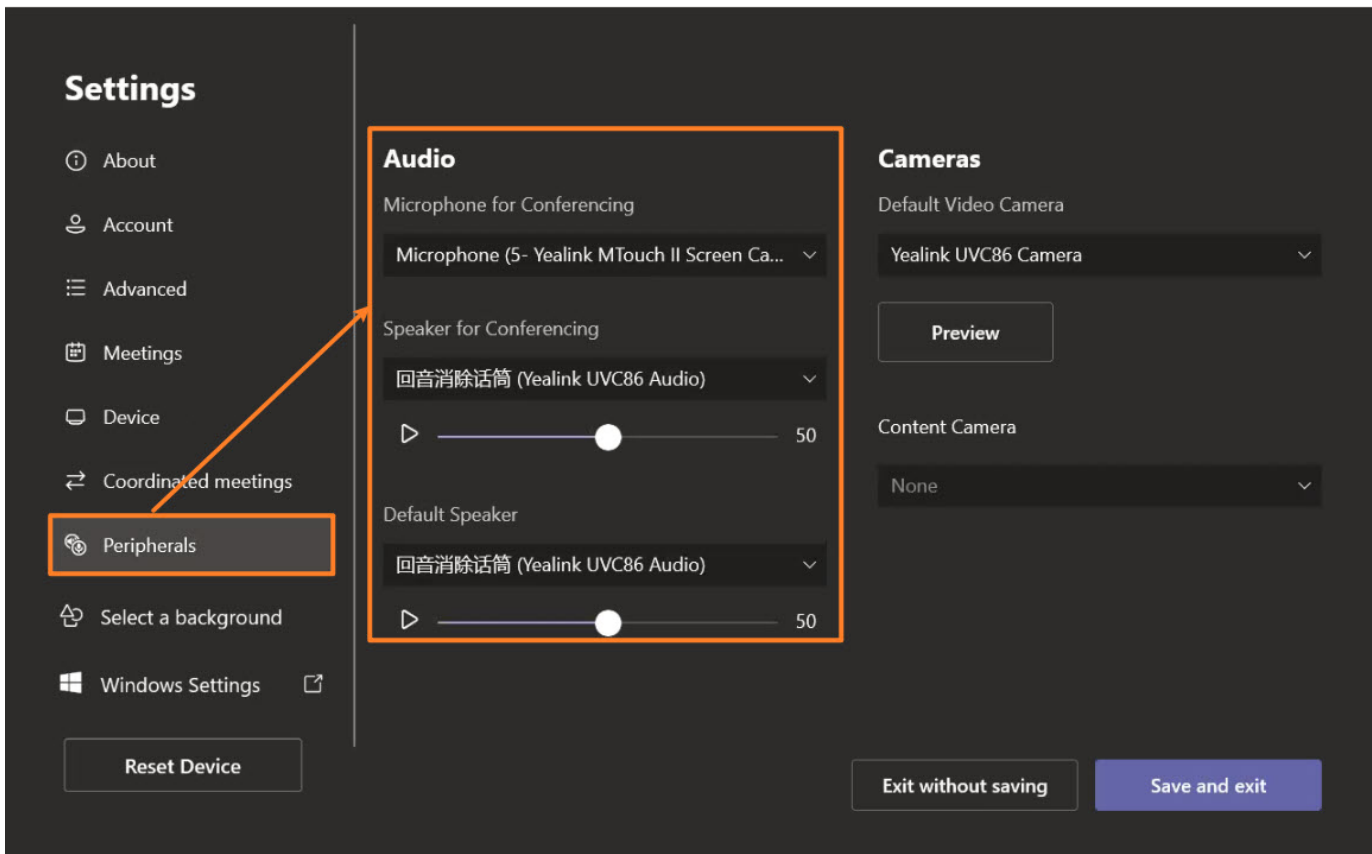

Yealink RoomConnect Audio Parameter Adjustment

Introduction

Adjust the device's gain through Yealink RoomConnect audio settings to control the signal strength and quality of recorded audio. The AI noise reduction feature automatically adjusts the noise reduction effect based on changes in the ambient noise. AEC echo cancellation suppresses or eliminates echoes in real-time audio, resulting in clearer and more natural sound during conversations. The NR noise reduction feature helps filter out and reduce or eliminate unwanted noise, interference, and disturbances generated during recording or playback, ensuring participants' voices are clearer and enhancing conference quality and audibility. Enabling the PEQ adjustment permits volume adjustments of audio signals within specific frequency ranges, thereby adjusting audio quality and volume.

Before You Begin

AVHub is supported in 153.432.0.5 and later visions.
 Yealink RoomConnect is supported in 2.32.42.0 and later visions.
 UVC86 is supported in 151.432.0.5 and later visions.

Access Point

- a.AVHub
- b.UVC86
- c.Microphone

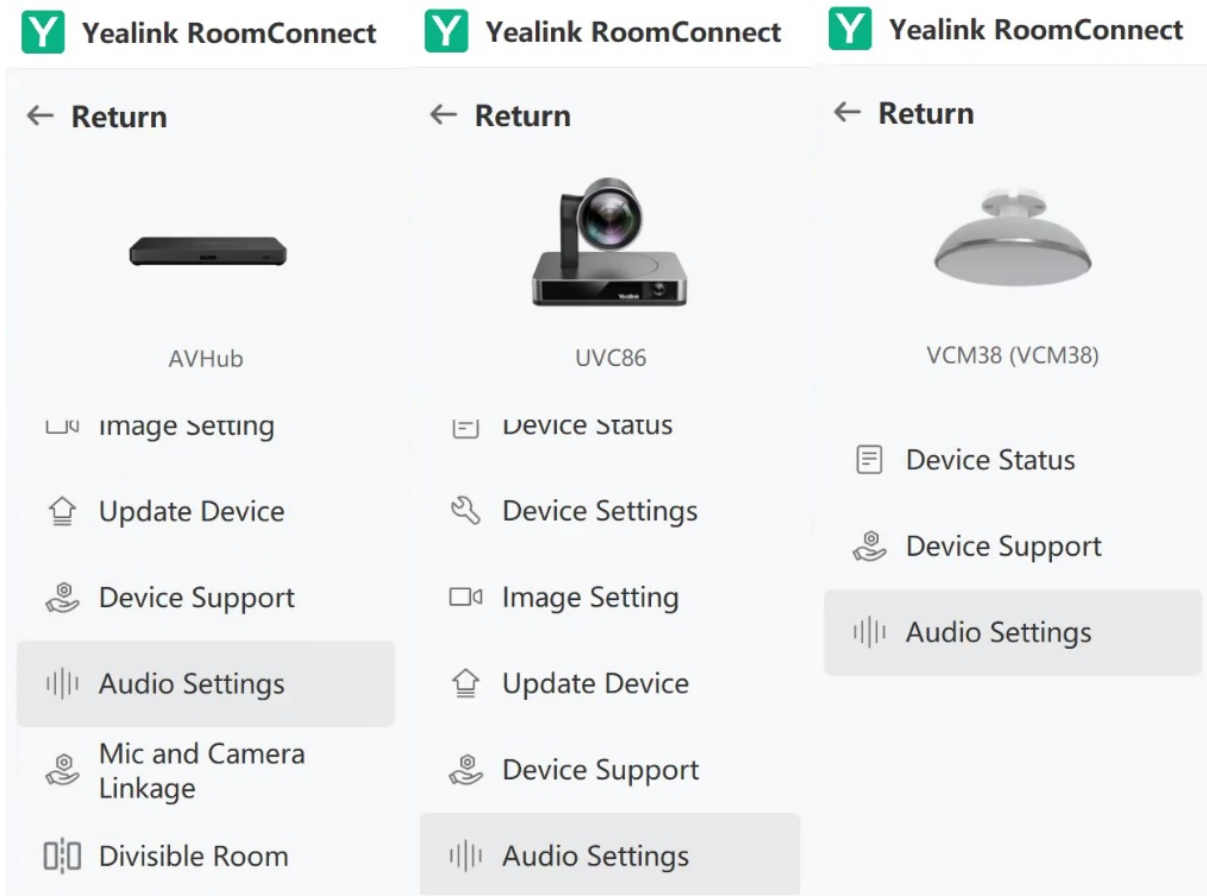

How to Use

You can directly use MTouch for operations or perform operations remotely. For remote management, please refer to [Remote Control](#).

NOTE
 The appearance/entrance may vary when different devices are connected. Therefore, the operation images below are just one of the possibilities.

Gain

Adjusting the device gain will affect the strength and quality of recorded audio signals. Increasing or decreasing the gain will yield different outcomes. Increasing the gain can influence volume amplification, making subtle volume changes more pronounced, widening the gap between high and low frequencies, and enhancing ambient sounds. However, excessive gain might amplify noise. Decreasing the gain can reduce noise, narrow the gap between high and low frequencies, soften sound, and lower volume. You can adjust as needed.

1. Click **AVHub > Audio Settings**.

2. Click **Gain** in **Audio Input/Output Adjustment**.

The screenshot shows the 'Audio Input/Output Adjustment' settings. At the top, there are three tabs: 'Gain' (highlighted with an orange box), 'AEC', and 'EQ'. Below the tabs are three sliders: 'RCA Input Control' at 0dB, 'Line Input Control' at 0dB, and 'Automatic Gain Control' which is turned on. Below these is a grey box containing two level meters: 'Input Level (dBFS)' and 'Output Level (dBFS)', both ranging from -100 to 0. At the bottom, there is a 'Gain' slider set to 0dB, with minus and plus buttons on either side.

AI Noise Reduction

The noise reduction effect can be automatically adjusted based on changes in the ambient noise environment.

1. Click **AVHub > Audio Settings**.
2. Enable **AI Noise Reduction**.



Microphone ?

Separate Microphone Mute Control ?



AI Noise Reduction



Audio Input Adjustment

AEC Echo Cancellation

The AEC technology suppresses or eliminates echoes in real-time audio, resulting in clearer and more natural sound during conversations.

1. Click **AVHub > Audio Settings**.
2. Adjust **AEC** in **Audio Input Adjustment**.
3. Enable **Echo Cancellation** and adjust the value of Echo Delay.

⚙️ | — ×

Gain
AEC
NR
EQ

Echo Cancellation	<input checked="" type="checkbox"/>
AEC Suppress Level	Low ▾
AEC Reverb Level	Low ▾
Manual AEC Echo Delay ?	<input checked="" type="checkbox"/>
Delay	0ms >

NR

The NR noise reduction feature assists in filtering and reducing or eliminating unwanted noise, interference, and unnecessary disturbances generated during recording or playback. This enhances the clarity of participants' voices, thereby improving the quality and audibility of the conference.

1. Click **AVHub > Audio Settings**.
2. Adjust NR in **Audio Input Adjustment**.

⚙️ | — ×

Microphone ?

Separate Microphone Mute Control ?

AI Noise Reduction

Audio Input Adjustment

Gain
AEC
NR
EQ

Noise Reduction Level Normal ▾

3. Select **NR Suppress Level**.

Microphone ?

Separate Microphone Mute Control ?

AI Noise Reduction

Audio Input Adjustment

Gain AEC

Noise Reduction Level

Close
Low
Normal
High

Normal ^

Audio Output Adjustment

Gain EQ

Automatic Gain Control

NOTE

You can choose **Close, Low, Normal, or High** as needed.

EQ

EQ is an audio processing tool typically used to adjust the frequency response of an audio signal. EQ is used to enhance sound quality, eliminate noise, remove unwanted frequencies, or emphasize specific frequencies to adapt to different types of music or audio environments.

1. Click **AVHub > Audio Settings**.
2. Click **EQ** in **Audio Input/Output Adjustment**.
3. Enable EQ Adjustment.



Gain AEC NR **EQ | ↻** 1

PEQ Adjustment



Custom Bass Boost Treble Boost Vocal Boost 2

10 sliders for frequency response adjustment. Each slider has a frequency label and a value of 0.

Frequency	Value
20	0
63	0
125	0
250	0
500	0
1K	0
2K	0
4K	0
8K	0
20K	0

NOTE
You can choose **Custom, Bass, Treble Boost, or Voice Boost** as needed.

Connecting Different Devices, the Interface Changes.

When Connecting a Wired Microphone (VCM34, VCM35, VCM38)

a. Microphone

1. Click **Microphone card > Audio Settings**.
2. Adjust AEC and NR.

Y Yealink RoomConnect
⚙️ | — | ✕

← Return



VCM38 (VCM38)

- ☰ Device Status
- 🛎 Device Support
- 🔊 Audio Settings

AEC

AEC Suppress Level Low ▾

AEC Reverb Level Low ▾

Manual AEC Echo Delay

Delay 0ms >

NR

Noise Reduction Level Normal ▾

b. AVHub, UVC86

1. Click **AVHub** or **UVC86** > **Audio Settings**.
2. Adjust Gain and EQ.

Y Yealink RoomConnect
⚙️ | — | ✕

← Return



AVHub

- 🖼 Image Setting
- 🏠 Update Device
- 🛎 Device Support
- 🔊 Audio Settings
- 🛎 Mic and Camera Linkage
- 🏠 Divisible Room

AI Noise Reduction

Audio Input Adjustment

Gain

EQ

RCA Input Control 0dB

Line Input Control 0dB

Automatic Gain Control

Input Level (dBFS) -100 -80 -60 -40 -20 0

Output Level (dBFS) -100 -80 -60 -40 -20 0

Gain 0dB - +

When Connecting a Wireless Microphone (VCM34, VCM35, VCM38)

1. Click **AVHub** or **UVC86** > **Audio Settings**.
2. Adjust Gain and EQ.

Y Yealink RoomConnect
⚙️ | — | ×

← Return



AVHub

- 🖥️ Image Setting
- 🏠 Update Device
- 👤 Device Support
- 🔊 Audio Settings
- 👤 Mic and Camera Linkage
- 🗉 Divisible Room

AI Noise Reduction

Audio Input Adjustment

Gain
EQ

RCA Input Control 0dB

Line Input Control 0dB

Automatic Gain Control

Input Level (dBFS) -100 -80 -60 -40 -20 0

Output Level (dBFS) -100 -80 -60 -40 -20 0

Gain 0dB +

When Connecting non-Yealink Devices

When using Line and RCA interfaces to connect AVHub devices.

1. Click **AVHub > Audio Settings**.
2. Adjust AEC, NR, Gain and EQ.

Y Yealink RoomConnect
⚙️ | — | ×

← Return



AVHub

- 📄 Device Status
- 🔧 Device Settings
- 🖥️ Image Setting
- 🏠 Update Device
- 👤 Device Support
- 🔊 Audio Settings

Microphone ?

Separate Microphone Mute Control

AI Noise Reduction

Audio Input Adjustment

Gain
AEC
NR
EQ

RCA Input Control 0dB

Line Input Control 0dB

Automatic Gain Control

Input Level (dBFS) -100 -80 -60 -40 -20 0

Accessories

AVHub Audio & Video Processor

Introduction

Yealink AVHub is a meeting audio and video processor in large/extra-large conference rooms. AVHub supports multi-camera, multi-microphone, and multi-speaker, and combined with audio and video processing capability, AVHub can release PC performance. In addition, cameras, microphones, and speakers can be directly connected to the AVHub through the network cable PoE, reducing wiring and managing video and audio equipment uniformly. Users can adjust the camera layout with the Yealink plug-in before or even in MTR meetings when using the AVHub.

AVHub Compatibility

For the compatible devices and the maximum number of compatible devices, please refer to [Teams Room Accessories Compatibility Lists](#).

How to Use

Installation AVHub

For more information, please refer to [Installation](#).

Connect AVHub

For more information, please refer to [Connection](#).

LED Indicator

LED Status	Description
LED indicator off	The AVHub is powered off.
Solid red	The AVHub is in sleep status. The PC is not connected after the AVHub is powered on.
Fast flashing red	Resetting the AVHub.
Solid orange	The AVHub is starting up.
Fast flashing orange	The AV-Hub is upgrading firmware.
Solid green	The AVHub is working.

Camera Settings

AVHub supports connecting multiple cameras for the unified management of video devices. For more information, please refer to [AVHub & Multi-cameras Settings](#).

Update AVHub

AVHub can be automatically updated through the Yealink RoomConnect software. It will automatically detect whether the Yealink RoomConnect software version and the firmware version of all connected devices are the latest versions at 1:15 a.m. If not, it will automatically update all devices and Yealink RoomConnect software.

You can also manually update the Yealink RoomConnect software through the Yealink Device Management Platform or the Yealink RoomConnect software. For more information, please refer to [Firmware Update](#).

FAQ

[After connecting to a third-party PoE switch, AVhub cannot recognize the accessory.](#)

AVhub cannot recognize the accessory.

CPW65 Wireless Microphone

Introduction

Yealink CPW65 is a DECT Wireless Mic that is used for High-Quality Conference Room. Covered with black fabric, CPW65 is elegant, waterproof, greaseproof, and antifouling. Its 3 built-in microphones support a 360-degree voice pickup range with a 10-foot (3-meter) radius, which can guarantee you a balanced and crystal-clear audio experience. CPW65 is easy to use with intuitive capacitive mute buttons. What's more, just by randomly putting CPW65 on the charger cradle, the charging is proceeding without worrying about its direction. Its long battery life can offer you 11-day standby time or 12-hour talk time, saving you from frequent charging. All of the advantages make CPW65 an ideal choice for organizations that need optimal microphone placement and wider room coverage.

Device Compatibility

For the CPW65 compatible devices and the maximum number of compatible devices, please refer to [Teams Rooms Accessories Compatibility Lists](#).

How to Use

Installation

Please refer to: [CPW65 Installation](#).

Bind/Unbind the CPW65

CPW65 supports binding with UVC86/UVC84/AVHub. The method is as follows:

1. Insert WDD60 into the USB port of UVC86/UVC84/AVHub.
2. Open the Yealink RoomConnect software, click the UVC86/UVC84/AVHub card, and in Device Status > Wireless expansion microphone, click Bind.
3. Put the CPW65 on the charger cradle and long press the Mute Button for 5 seconds to enter the binding mode, and the Mute LED indicator flashes yellow. After the binding is successful, the Yealink RoomConnect software will display that CPW65 wireless is connected.
 - After the binding is successful, click Check > Device Settings > Unbind to unbind the wireless microphone.
 - Click **Check > Device Settings > Add Wireless Microphone** to add another wireless microphone again.
 - Click **Check > Device Settings > find**, and you can see the Mute LED indicator on corresponding CPW65 flashes red and green alternately. Currently, UVC86/UVC84/AVHub supports adding up to 2 (1 pair) CPW65 wireless microphones.

Mute/Unmute Microphone

Please refer to: [Mute/Unmute Microphone](#).

Hardware Introduction

Please refer to: [Hardware Introduction](#).

LED Indicator

Please refer to: [LED Indicator](#).

Charging CPW65

Please refer to: [Charge CPW65](#).

VCM34 Array Microphone

Introduction

VCM34 is a video conferencing microphone array that can work as the audio input device for Yealink Video Conferencing System or Yealink UVC PTZ Camera

to match more meeting room scenarios and reduce installation costs. With a built-in 3-microphone array and superior audio technology, VCM34 owns a 20ft (6m) and 360° voice pickup range, regarded as an ideal solution for any conference room that needs the best audio experience. VCM34 supports PoE, which enables simple and easy deployment. In this way, power supply data transmission and signal control unify as one, sharply reducing the complex installation procedures as well as the costly expenses.

VCM34 Compatibility

For the VCM34 compatible devices, please refer to [Teams Room Accessories Compatibility Lists](#).

How to Use

Connect MVC to VCM34

1. Remove the rear cover of VCM34

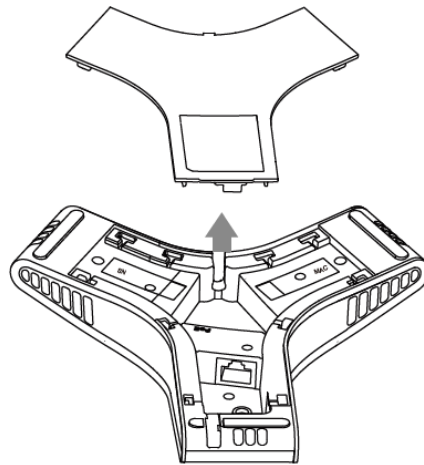

2. Connect VCM34 to UVC camera/AVHub

NOTE
You can simultaneously connect up to 4 VCM34 microphones in series, but more than 4 microphones need a star cascade connection.

Method 1: Connect to the VCH port of the UVC camera/AVHub:

You can connect one VCM34 microphone to the VCH port of the UVC camera/AVHub, or you can cascade the VCM34 in an array and connect the last one to the VCH port of the UVC camera/AVHub.

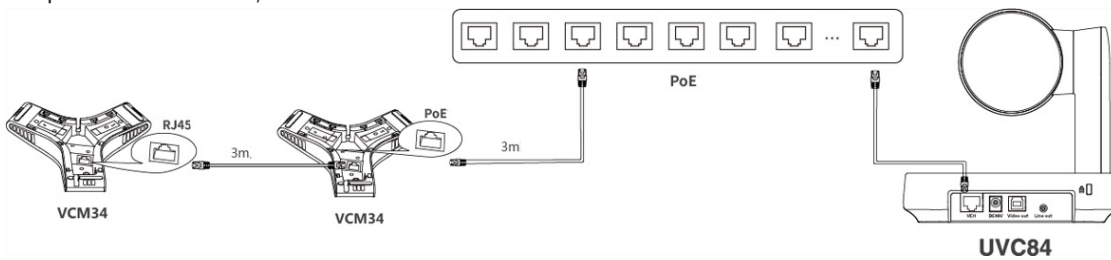

Method 2: Connect via the PoE switch

- **Series connection:** Cascade multiple VCM34s to the PoE switch and then connect the PoE switch to the VCH Port

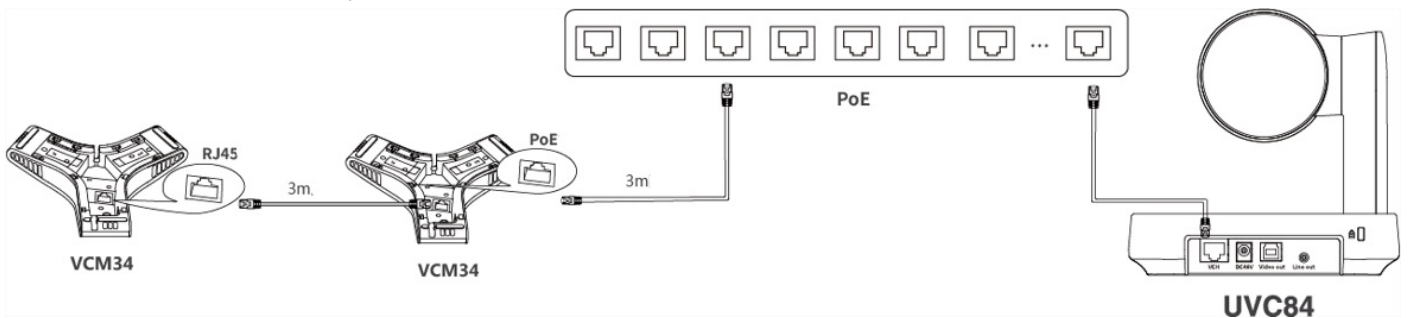

- **Star cascade:** Connect multiple VCM34 microphones to the PoE switch, and then connect the PoE switch to the VCH Port.

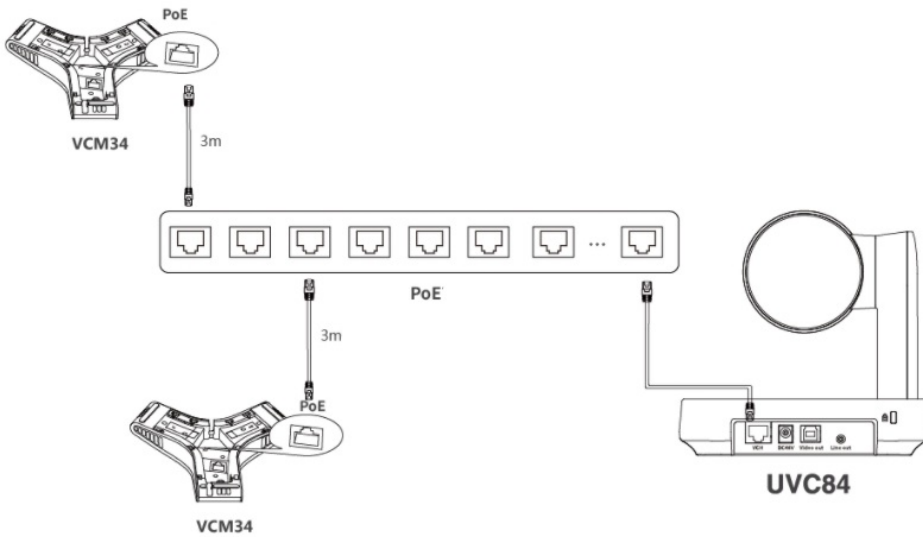

Method 2: Connect via AVHub

You can connect the UVC cameras and VCM34 to the AVHub simultaneously.

NOTE

When you connect the UVC84/UVC86/MSpeaker II directly to the AVHub, the total number of connections must be no more than 4 devices. If the total number of connections exceeds 4 devices, you need to connect a PoE switch (the PoE switch must meet the 802.3 AT (PoE+) standard).

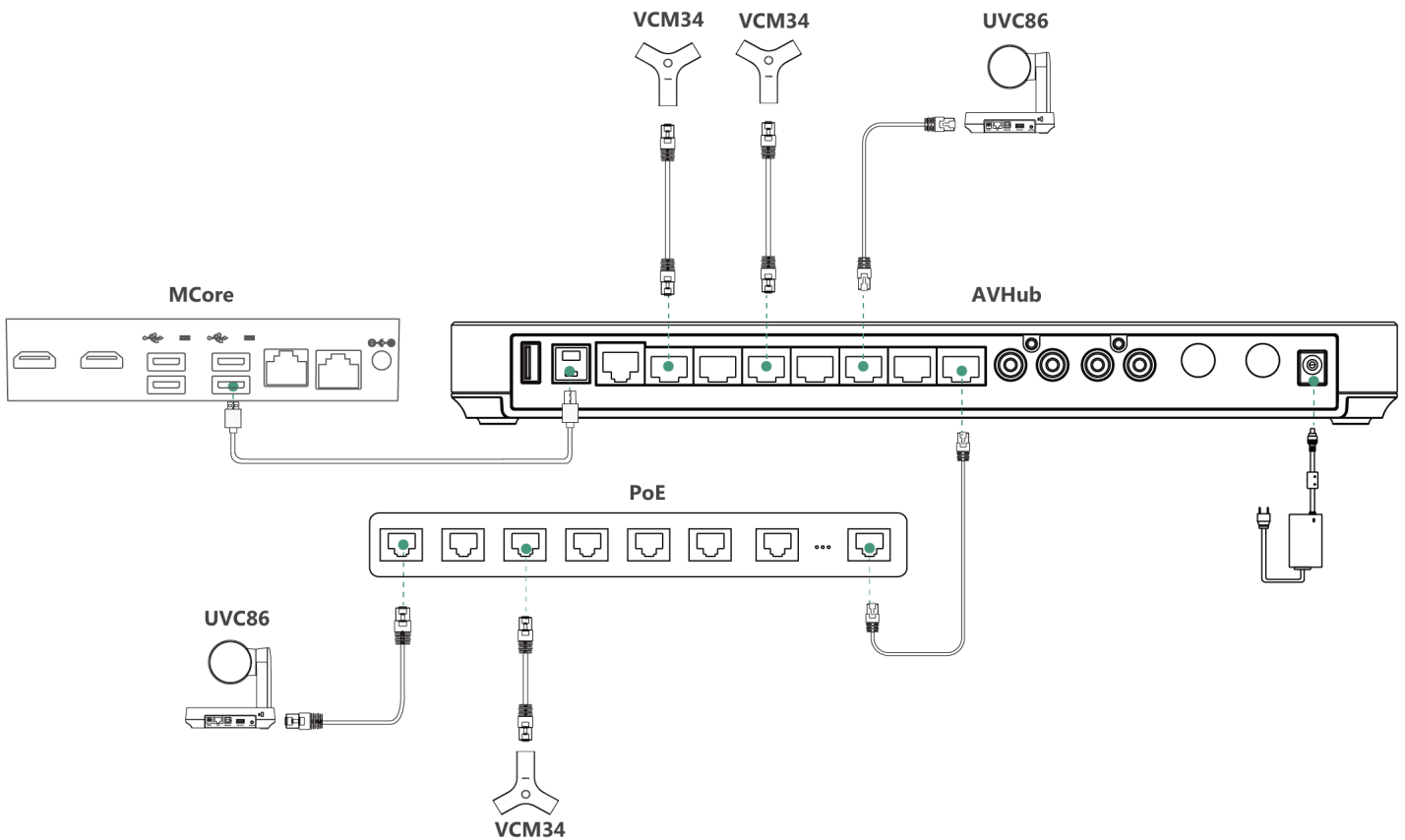

Mute/Unmute Microphone

Please refer to: [Mute/Unmute Microphone](#).

Audio Settings

You can choose the microphone used in the meeting, and please refer to [Audio Settings](#).

Update VCM34

After connecting the VCM34 to the MVC device, it will automatically obtain the ROM package from the MVC device to update.

You can also manually update through the Yealink Device Management Platform. For more information, please refer to [Firmware Update](#).

FAQ

Can VCM34 and MVC' s built-in microphone pick up sound at the same time?

The VCM34 is an external microphone and does not support simultaneous sound pickup with the built-in microphone. You can set which microphone to use for pickup on MTouch II. For the operation method, please refer to [Audio Settings](#).

After connecting the MVC to the VCM34, the VCM34 cannot pick up the audio/there is no response when touching the VCM34 mute button.

MVC does not support the simultaneous use of multiple microphone devices. Please check whether other microphones are connected at the same time. For more information, please refer to [Does MVC support multiple microphone devices simultaneously?](#)

How to reset the VCM34 microphone?

The VCM34 microphone has no reset feature.

VCM35 Video Conferencing Microphone

Introduction

Yealink VCM35 is a wired video conferencing microphone array specially designed for the new generation of Yealink Video Conferencing System. Its built-in 3-microphone array with a 20ft (6m) and 360° voice pickup range is an ideal solution for any conference room that needs the best audio experience. With the Yealink Acoustic Echo Canceling and Yealink Noise Proof Technology, Yealink VCM35 can effectively reduce ambient noise up to 90 dB and give you a high-quality audio experience in full-duplex calls. Yealink VCM35 supports star-cascaded deployment, and its extremely high scalability and flexibility make deployment more convenient and faster and can fully cover conference rooms of various sizes.

VCM35 Compatibility

For the VCM35 compatibility, please refer to [Teams Room Accessories Compatibility Lists](#).

How to Use

Connect MVC to VCM35

Method 1: Connect to the VCH port of the UVC camera/AVHub:

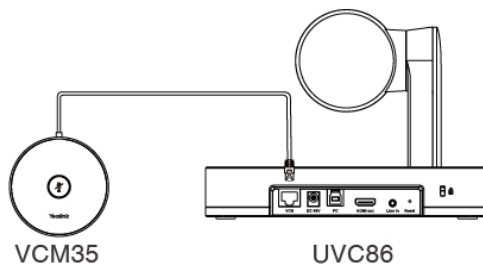

Method 2: Connect via the PoE switch

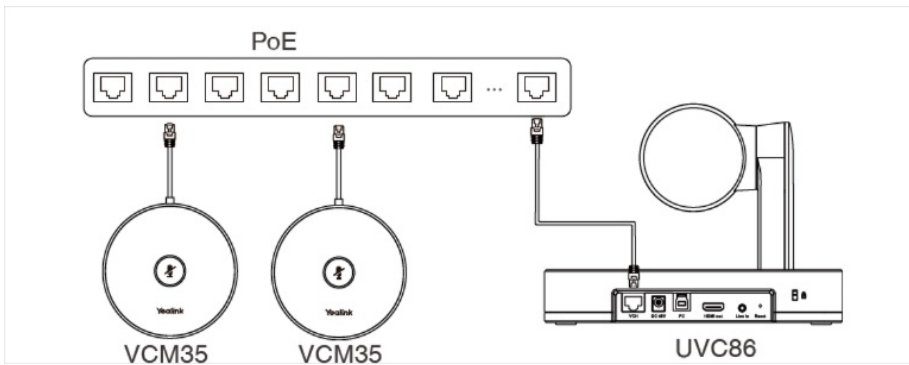

Method 2: Connect via AVHub

You can connect the UVC cameras and VCM35 to the AVHub simultaneously.

When you connect the UVC84/UVC86 directly to the AVHub, the total number of connections must be no more than 4 devices. If the total number of connections exceeds 4 devices, you need to connect a PoE switch (the PoE switch must meet the 802.3 AT (PoE+) standard).

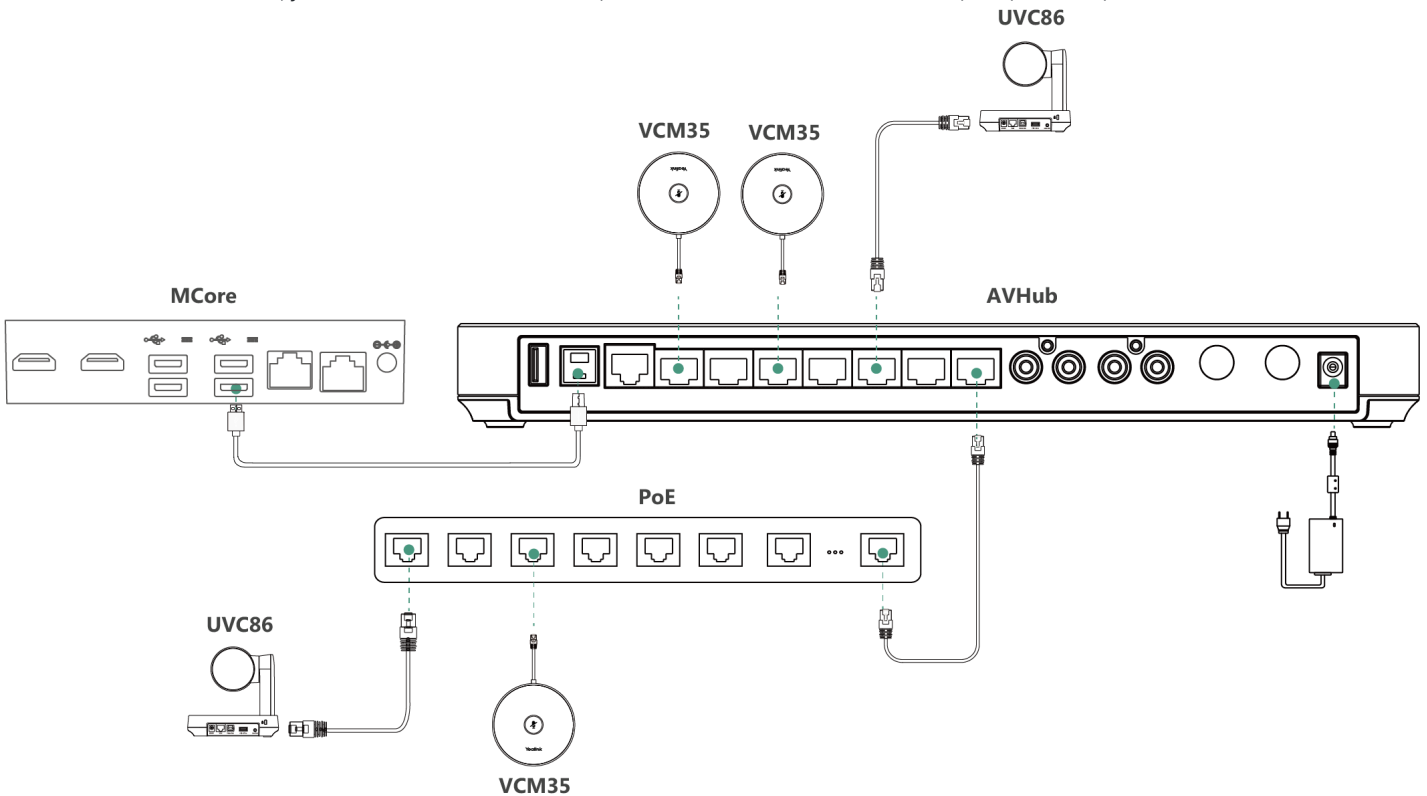

LED Indicator

Please refer to: [LED Indicator](#).

Mute/Unmute Microphone

Please refer to: [Mute/Unmute Microphone](#).

Audio Settings

If you want to manually set the specified audio input device after connecting the VCM35 to the MVC device, please refer to [Audio Settings](#).

Update VCM35

After connecting the VCM35 to the MVC device, it will automatically obtain the ROM package from the MVC device to update.

You can also manually update through the Yealink Device Management Platform. For more information, please refer to [Firmware Update](#).

FAQ

Can VCM35 and MVC' s built-in microphone pick up sound at the same time?

The VCM35 is an external microphone and does not support simultaneous sound pickup with the built-in microphone. You can set which microphone to use for pickup on MTouch II. For the operation method, please refer to [Audio Settings](#).

After connecting the MVC to the VCM35, the VCM35 cannot pick up the audio/there is no response when touching the VCM35 mute button.

MVC does not support the simultaneous use of multiple microphone devices. Please check whether other microphones are connected at the same time. For more information, please refer to [Does MVC support multiple microphone devices simultaneously?](#)

How to reset the VCM35 microphone?

The VCM35 microphone has no reset feature.

VCM36-W Wireless Microphone

Introduction

The Yealink VCM36-W is an innovative wireless video conferencing microphone designed to accommodate a wide range of meeting room needs. With a built-in 3-microphone array, the VCM36-W has a 20ft (6m) and 360° voice pickup range. It features Yealink's high-quality echo cancellation technology and noise cancellation, effectively filtering out up to 90dB of ambient noise to provide a high-quality audio experience during full-duplex calls. The VCM36-W's high-quality pickup technology enables it to provide a full range of audio coverage for all sizes of conference rooms. The VCM36-W is easy to use with a single pairing, with up to 12 hours of battery life in conference mode and 7 days of standby time. The VCM36-W WIFI microphone is equipped with a charging dock that allows you to charge the microphone wirelessly, and you can change its deployment position at any time while using it to suit your needs.

VCM36-W Compatibility

For the VCM36-W compatible devices, please refer to [Teams Room Accessories Compatibility Lists](#).

How to Use

Hardware Introduction

Please refer to: [Hardware Introduction](#).

LED Indicator

Please refer to: [LED Indicator](#).

Charge

Please refer to: [Charge](#).

Power On and Off

Please refer to: [Power On and Off](#).

Connect MVC to VCM36-W

- **Method 1: Pair directly**

1. Use a USB cable to connect the Type-C port of VCM36-W to the USB port (PC port) of the UVC camera/AVHub. - When pairing, the mute LED indicator of the VCM36-W flashes yellow quickly. After the pairing is successful, you can see on the display connected to MCore: The wireless microphone pairing is successful, and you can check the VCM36-W on the Yealink RoomConnect application.

2. After disconnecting the cable, you can use the VCM36-W usually.

- **Method 2: Pairing via Yealink RoomConnect application**

1. Connect the Type-C port of the VCM36-W to the PC/MCore via a USB cable.

2. Connect the UVC camera/AVHub to the same PC/MCore via a USB cable.

3. Run the Yealink RoomConnect application on your PC. After pairing successfully, the VCM36-W card will appear on the Yealink RoomConnect application.

4. After disconnecting the cable, you can use the VCM36-W usually.

NOTE

VCM36-W currently only supports wired pairing.

Unpair VCM36-W

Method 1:

Pair the VCM36-W with a new device to cancel the pairing of the VCM36-W with the original device.

Method 2:

Turn off the AP (wireless hotspot) of the UVC device to cancel the VCM36-W pairing and the original device.

1. Open the Yealink RoomConnect application and select the paired device.
2. Select **Settings**.
3. Disable **AP**.

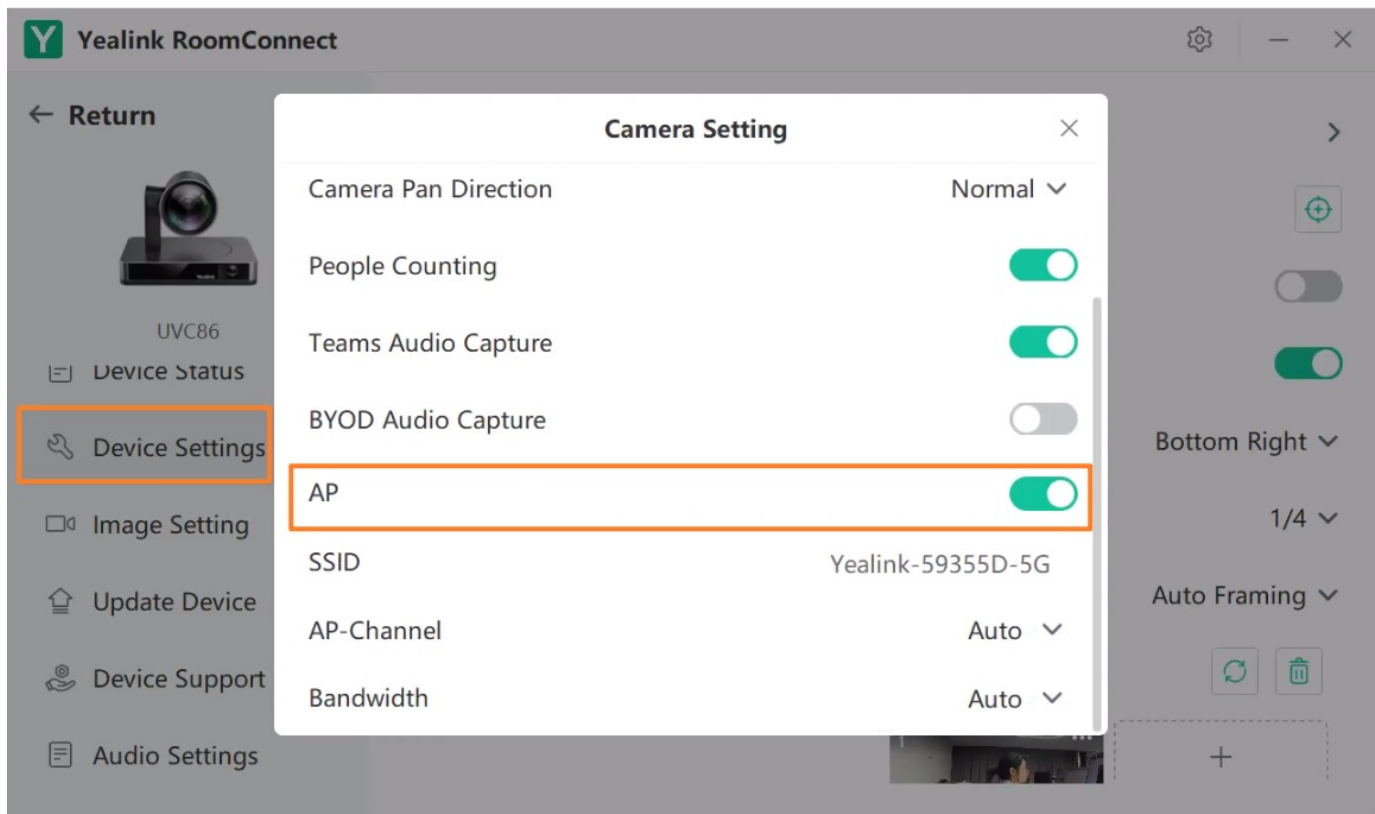

Mute/Unmute Microphone

Please refer to: [Mute/Unmute Microphone](#).

Audio Settings

If you want to manually set the specified audio input device after connecting the VCM36-W to the MVC device, please refer to [Audio Settings](#).

Update VCM36-W

NOTE

Make sure the VCM36-W has enough power before upgrading.

After connecting the VCM36-W to the MVC device, it will automatically obtain the ROM package from the MVC device to update.

You can also manually update through the Yealink Device Management Platform. For more information, please refer to [Firmware Update](#).

FAQ

Can VCM36 and MVC' s built-in microphone pick up sound at the same time?

The VCM36 is an external microphone and does not support simultaneous sound pickup with the built-in microphone. You can set which microphone to use for pickup on MTouch II. For the operation method, please refer to [Audio Settings](#).

After connecting the MVC to the VCM36 , the VCM36 cannot pick up the audio/there is no response when touching the VCM36 mute button.

MVC does not support the simultaneous use of multiple microphone devices. Please check whether other microphones are connected at the same time. For more information, please refer to [Does MVC support multiple microphone devices simultaneously?](#)

How to reset the VCM36 microphone?

The VCM36 microphone has no reset feature.

Does the VCM36-W support using third-party video conferencing devices of the Android version?

VCM38 Ceiling Microphone

Introduction

VCM38 is a newly designed ceiling microphone with 8 built-in microphones for 360-degree sound pickup. VCM38 delivers excellent sound quality with high-quality echo cancellation and Yealink noise-proof technology. With Beamforming technology, VCM38 can automatically locate and optimize sound pickup for the person speaking.

A single VCM38 unit can cover 40 square meters, even for oversized meeting rooms by using up to eight VCM38 units in one system.

VCM38 supports PoE, which enables simple and easy deployment. It can be installed directly on the ceiling or by a telescopic rod which can be adjusted between 30~60cm to keep the room table clean and can match more meeting room scenarios.

VCM38 Compatibility

For the VCM38 compatible devices, please refer to [Teams Room Accessories Compatibility Lists](#).

How to Use

Installation

Please refer to: [Installation](#).

Connect MVC to VCM38

Method 1: Connect to the VCH port of the UVC camera/AVHub:

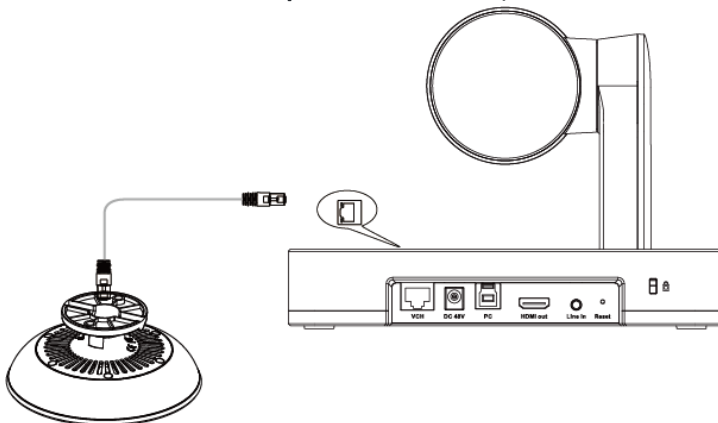

Method 2: Connect via the PoE switch

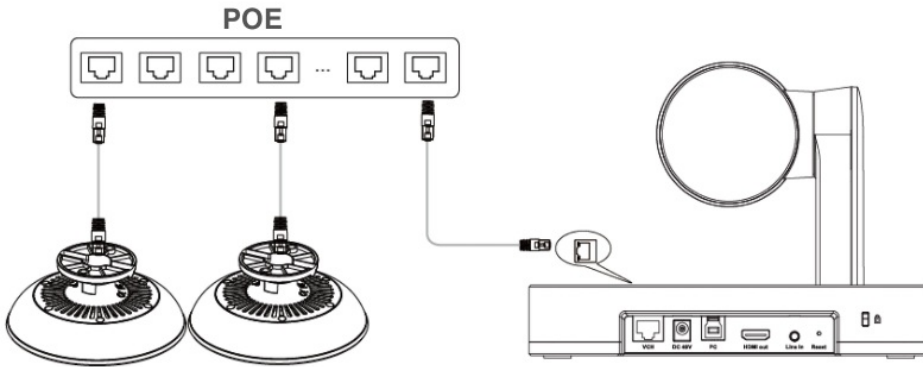

Method 2: Connect via AVHub

You can connect the UVC cameras and VCM35 to the AVHub simultaneously.

NOTE

When you connect the UVC84/UVC86/MSpeaker II directly to the AVHub, the total number of connections must be no more than 4 devices. If the total number of connections exceeds 4 devices, you need to connect a PoE switch (the PoE switch must meet the 802.3 AT (PoE+) standard).

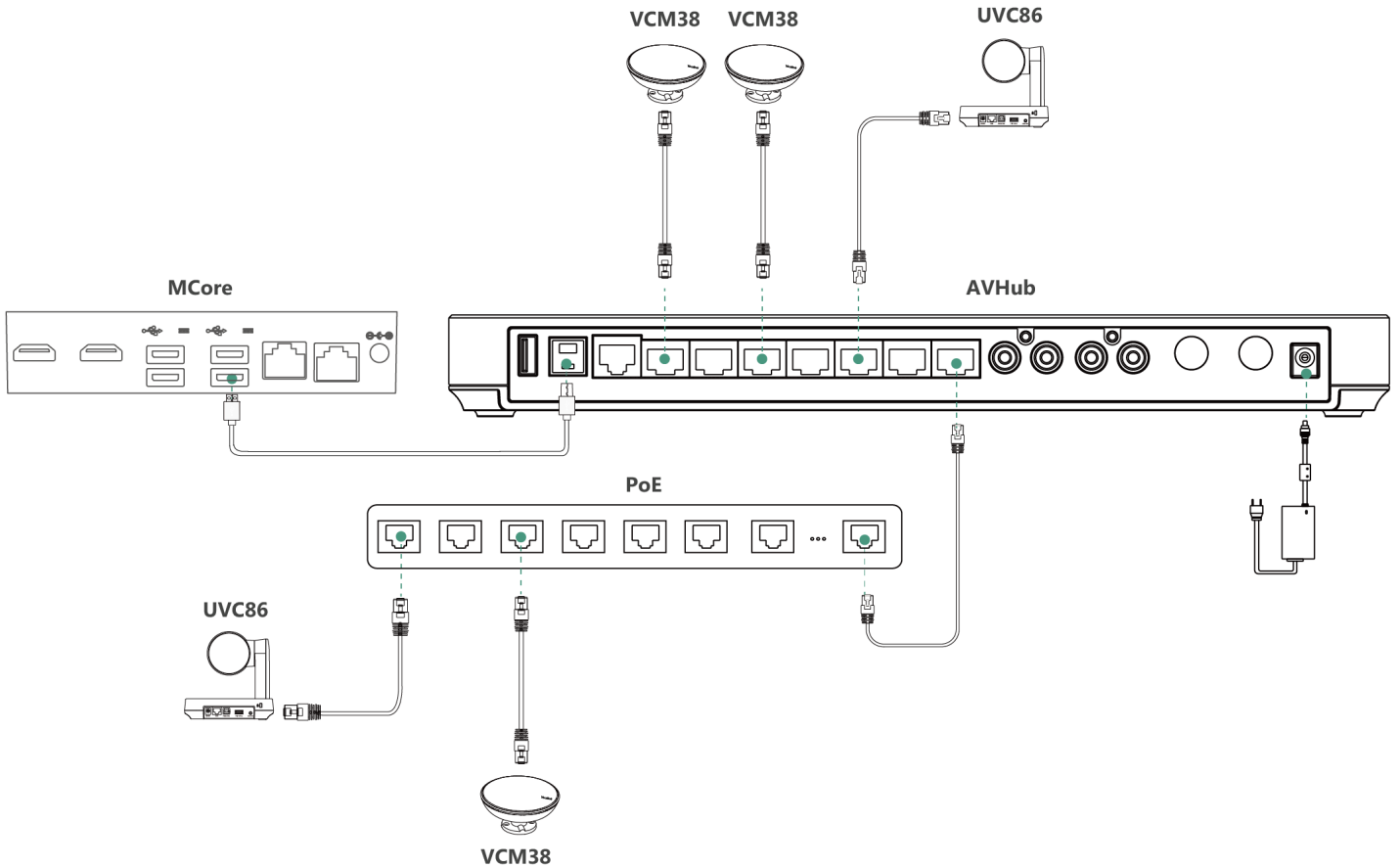

Mute or unmute Microphone

You can mute and unmute the VCM38 microphone through MTouch II, and please refer to [Separate Microphone Mute Control](#).

Audio Settings

If you want to manually set the specified audio input device after connecting the VCM38 to the MVC device, please refer to [Audio Settings](#).

Update VCM38

After connecting the VCM38 to the MVC device, it will automatically obtain the ROM package from the MVC device to update. You can also manually update through the Yealink Device Management Platform. For more information, please refer to [Firmware Update](#).

FAQ

Can VCM38 and MVC' s built-in microphone pick up sound at the same time?

The VCM38 is an external microphone and does not support simultaneous sound pickup with the built-in microphone. You can set which microphone to use for pickup on MTouch II. For the operation method, please refer to [Audio Settings](#).

After connecting the MVC to the VCM38, the VCM38 cannot pick up the audio/there is no response when touching the VCM38 mute button.

MVC does not support the simultaneous use of multiple microphone devices. Please check whether other microphones are connected at the same time. For more information, please refer to [Does MVC support multiple microphone devices simultaneously?](#)

How to reset the VCM36 microphone?

The VCM36 microphone has no reset feature.

CPW90 Wireless Microphone

Introduction

The Yealink CPW90 is a CP Wireless Expansion Mic that works as an audio input device for the Yealink CP960 conference phone. It features superior audio technology and supports a 360-degree voice pickup range at a radius of up to 10 feet (3 meters) without any wiring troubles. Capacitive mute touchpad plus place-and-charge charger cradle round out its user-friendly features, making Yealink CP Phone Wireless Expansion Mic CPW90 easy to use and an ideal choice for organizations who need optimal microphone placement and broader room coverage.

CPW90 Compatibility

For the CPW90 compatible devices, please refer to [Teams Room Accessories Compatibility Lists](#).

How to Use

Pair CPW90 with Camera via DD10.

1. Connect DD10 USB Dongle to Camera

Plug the DD10 into the USB-A port of the camera, and the connected display prompts “ **Wireless microphone adapter connected** ” .

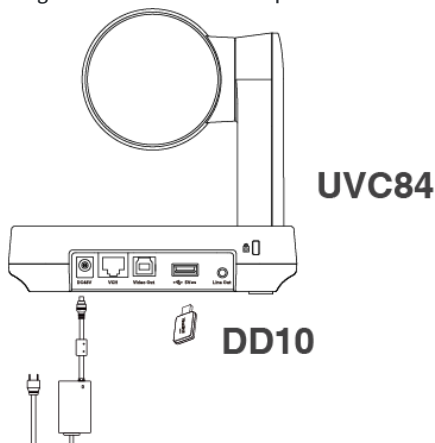

2. Pair CPW90 with Camera

Connect the CPW90 to the camera via USB until the CPW90' s LED indicator flashes yellow, and unplug the USB cable.

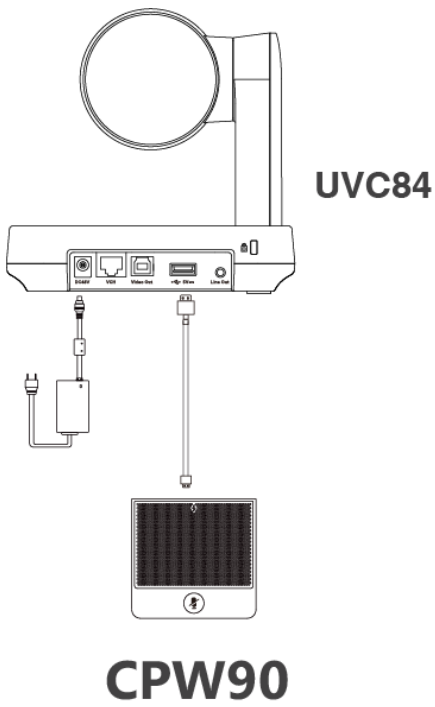

3. Connect DD10 to Camera Again

Plug the DD10 into the USB-A port of the camera to use directly.

Pair CPW90 with AVHub via DD10

1. Insert the DD10 into the USB port of your AVHub.
2. Open Yealink Room Connect and click **Add Wireless Microphone**.

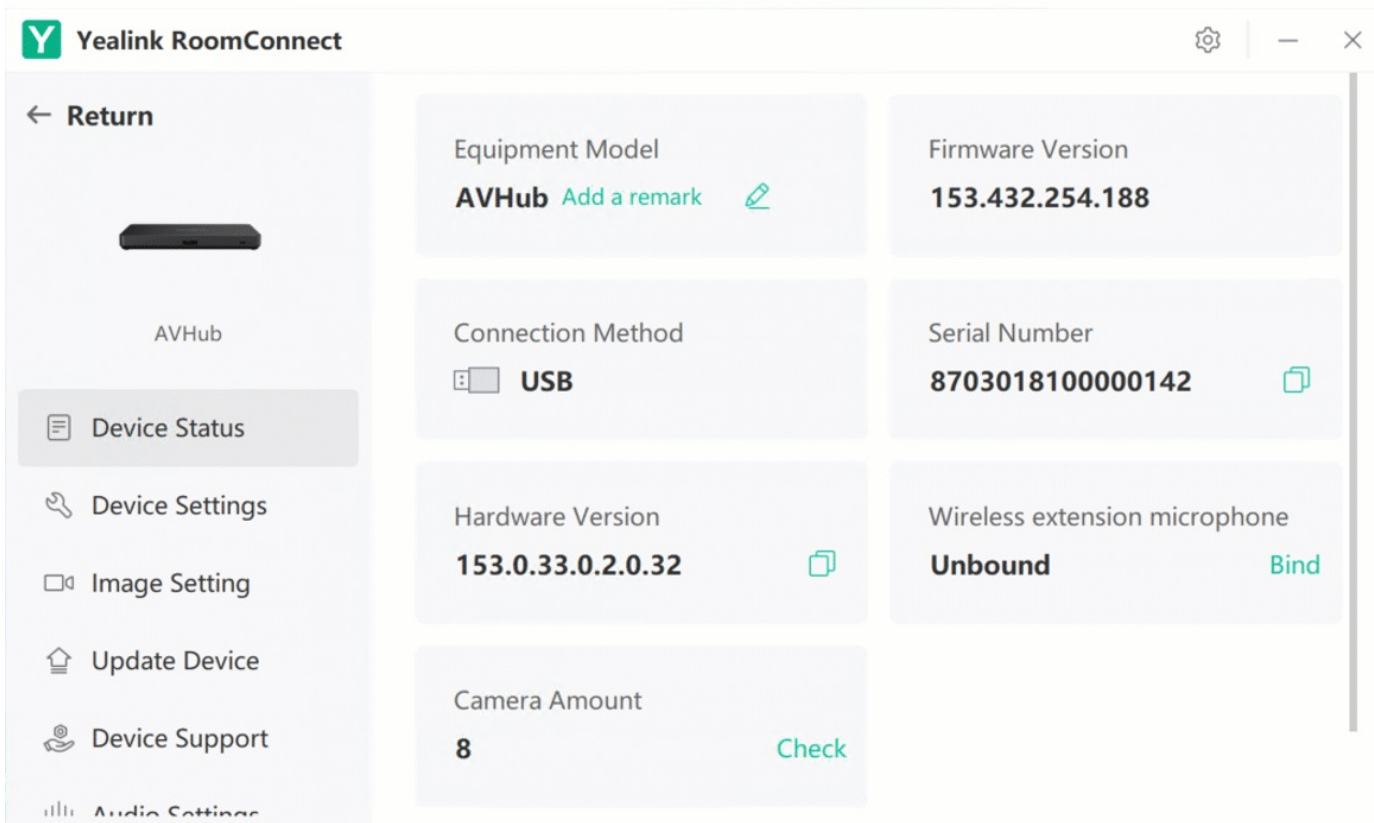

3. Long press the mute button of CPW90 until it turns yellow fast flashing. The Mute LED indicator is off, and then the wireless microphone is paired with the MVC940.

NOTE

If you want to find the paired wireless microphones, open Yealink Room Connect, click the device details of wireless microphone-CPW90, and click **Find**, The mute LED indicator of the microphone flashes red and green alternately.

Mute/Unmute Microphone

Please refer to [Mute/Unmute Microphone](#).

LED Indicator

Please refer to [LED Indicator](#).

MSpeaker II Soundbar

Introduction

Yealink MSpeaker II is designed for video conference rooms, allowing you to get a better sound experience in the room. It has two built-in speakers that can cover medium-sized and even large meeting rooms. Combined with the Yealink microphone and Yealink Noise Proof Technology, it brings a crystal and vivid audio experience to everyone. MSpeaker II supports PoE, which enables simple and easy deployment. In this way, power supply, audio data transmission and signal control unify as one, sharply reducing the complex installation procedures as well as the costly expenses. And MSpeaker II also supports 3.5mm AUX input to be compatible with more video conferencing solutions.

MSpeaker II Compatibility

For the MSpeaker II compatible devices, please refer to [Teams Room Accessories Compatibility Lists](#).

How to Use**Installation**

Please refer to: [Installation](#).

Connect MVC to MSpeaker II**Method 1: Connect to the Line out port of the UVC84:****NOTE**

- When using an audio cable connection, the MSpeaker II must be connected to a power source.
- Only the UVC84 supports audio cable connection.

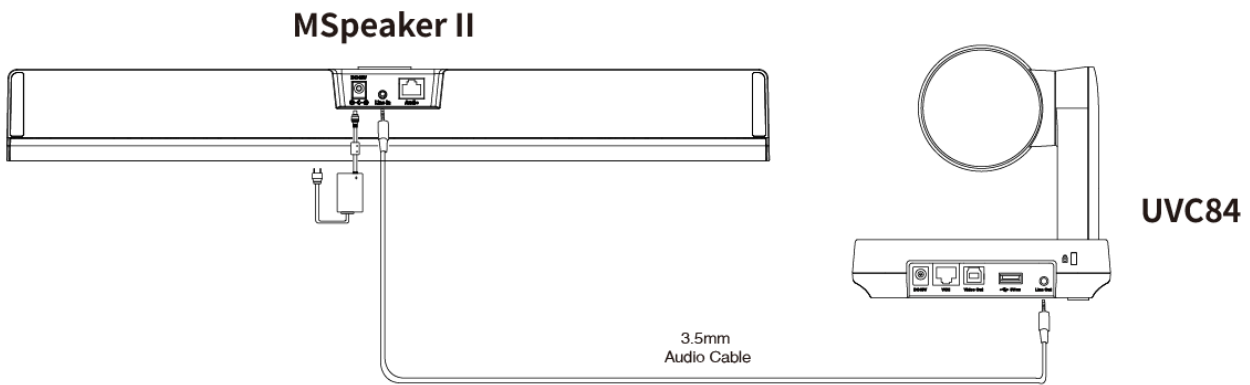

Method 2: Connect to the VCH port of the UVC camera/AVHub:

NOTE

The UVC84/UVC86/AVHub all support connection via the VCH port.

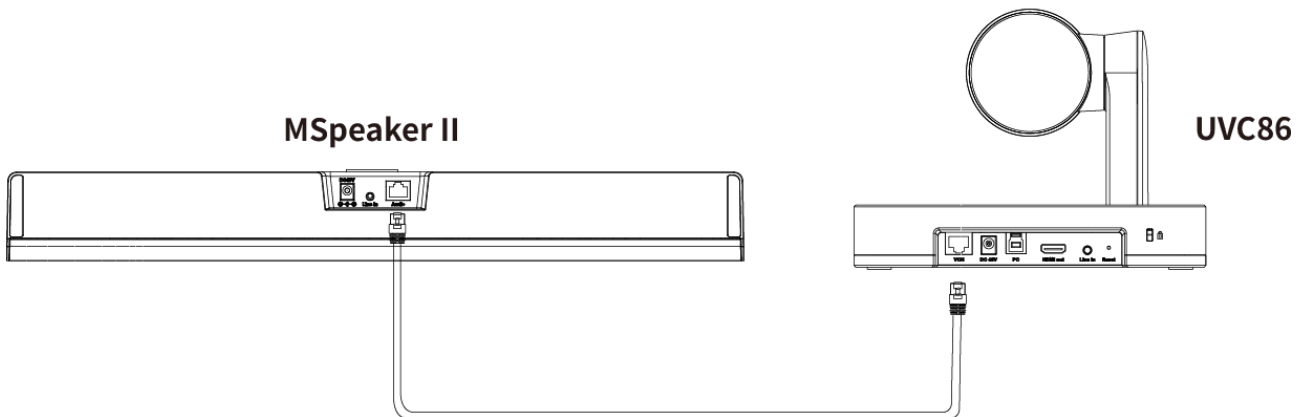

Method 3: Connect via the PoE switch

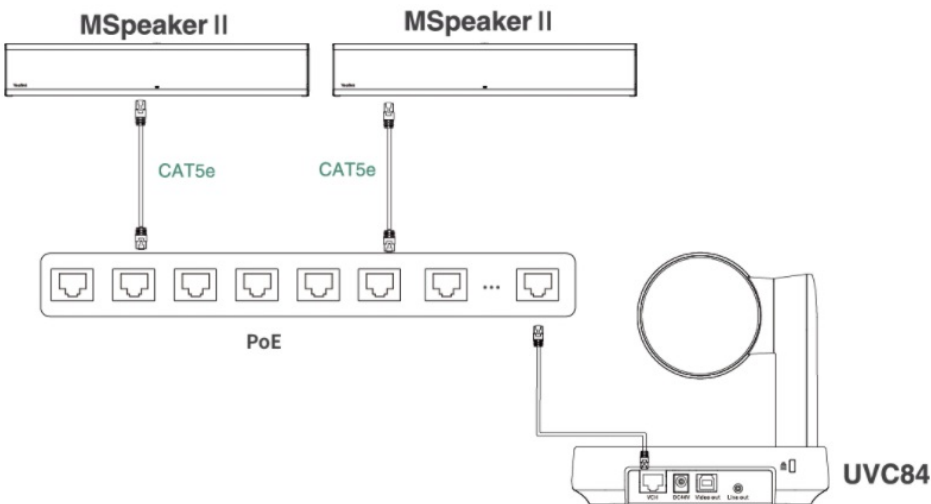

Method 4: Connect via AVHub

You can connect the UVC cameras and MSpeaker II to the AVHub simultaneously.

NOTE

When you connect the UVC84/UVC86/MSpeaker II directly to the AVHub, the total number of connections must be no more than 4 devices. If the total number of connections exceeds 4 devices, you need to connect a PoE switch (the PoE switch must meet the 802.3 AT (PoE+) standard).

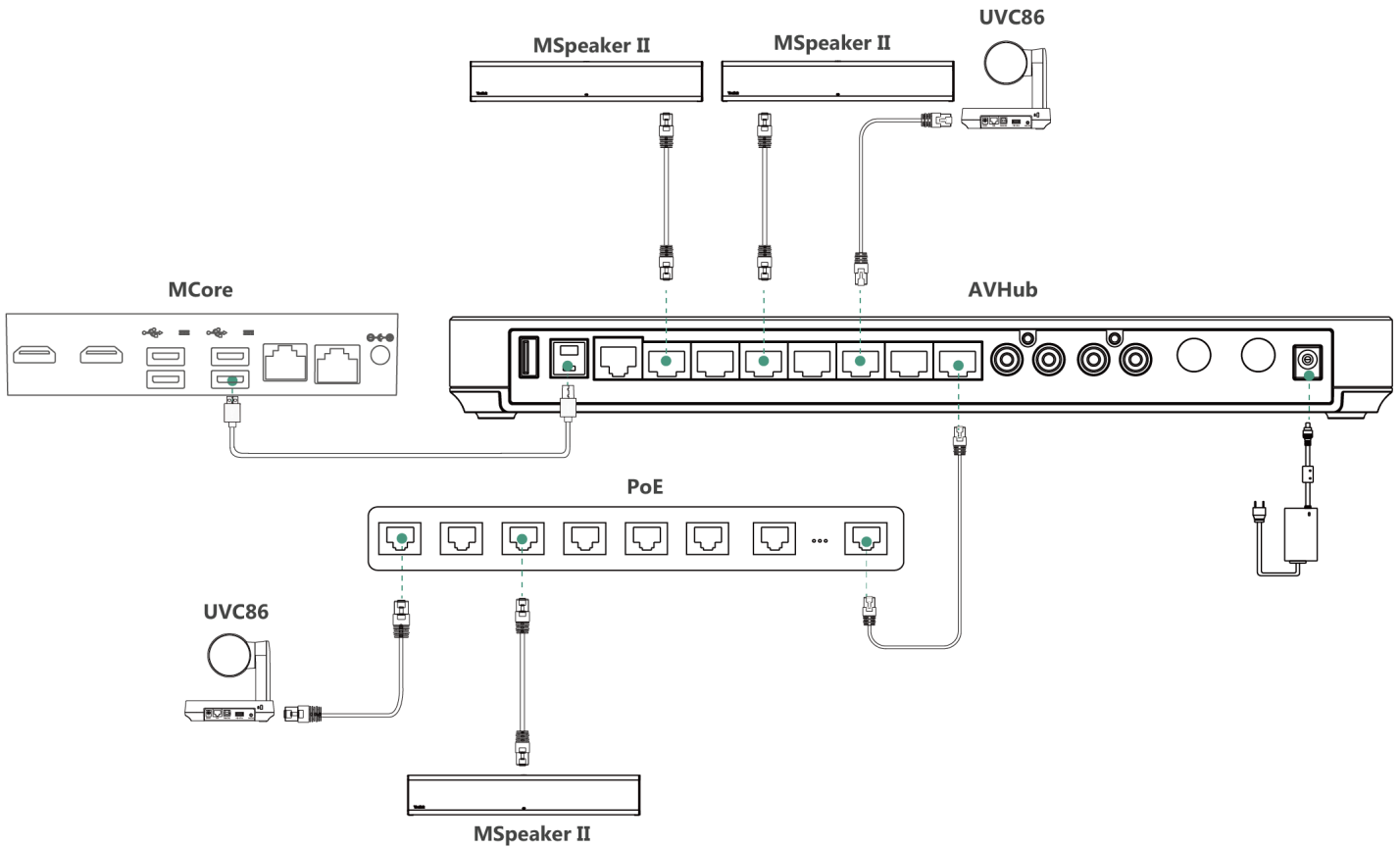

LED Indicator

Please refer to: [LED Indicator](#).

Update MSpeaker II

After connecting the MSpeaker II to the MVC device, it will automatically obtain the ROM package from the MVC device to update. You can also manually update through the Yealink Device Management Platform. For more information, please refer to [Firmware Update](#).

MSpeech

Introduction

Yealink MSpeech is specially designed for a video conferencing room to give you a better sound in a meeting room. It has two built-in speakers, providing powerful output to cover the middle and large meeting rooms. Working with Yealink microphone and Yealink Noise Proof Technology brings everyone a crystal and vivid audio experience.

MSpeech Compatibility

For the MSpeech compatible devices, please refer to [Teams Room Accessories Compatibility Lists](#).

How to Use

Connect MSpeech

NOTE

The MVC660 and MVC640 kits include an MSpeech, and MSpeech does not support multiple connections.

For more information, please refer to [Connection](#).

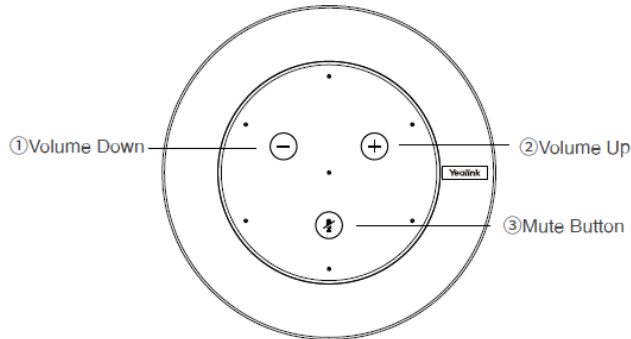
Hardware Introduction

- ① ② Tap to turn up/down volume.
- ③ Tap to mute/unmute microphone.

Update MSpeech

After connecting the MSpeech to the MVC device, it will automatically obtain the ROM package from the MVC device to update.

You can also manually update through the Yealink Device Management Platform. For more information, please refer to [Firmware Update](#).

FAQ

[Does MSpeech support using a cat5e cable to extend the connection?](#)

[How to restore the factory settings of MSpeech?](#)

Room Sensor Energy Saving Mode

Introduction

Configure the energy-saving schedule for the Room Sensor on Yealink RoomConnect by setting working hours. This ensures that the Room Sensor enters an ultra-low power mode during non-working hours, conserving energy and thereby extending the built-in battery life of the Room Sensor.

Before You Begin

MTouch Plus is supported in 282.432.0.5 and later visions.

Roomsensor is supported in 270.352.0.75 and later visions.

Yealink RoomConnect is supported in 2.32.42.0 and later visions.

How to Use

You can directly use MTouch for operations or perform operations remotely. For remote management, please refer to [Remote Control](#).

Switch to **Windows Mode**. For instructions on how to switch, please refer to Switch Account [Yealink Support](#).

Configure working time

1. Click **MTouch Plus > Device Status > Sensor**.

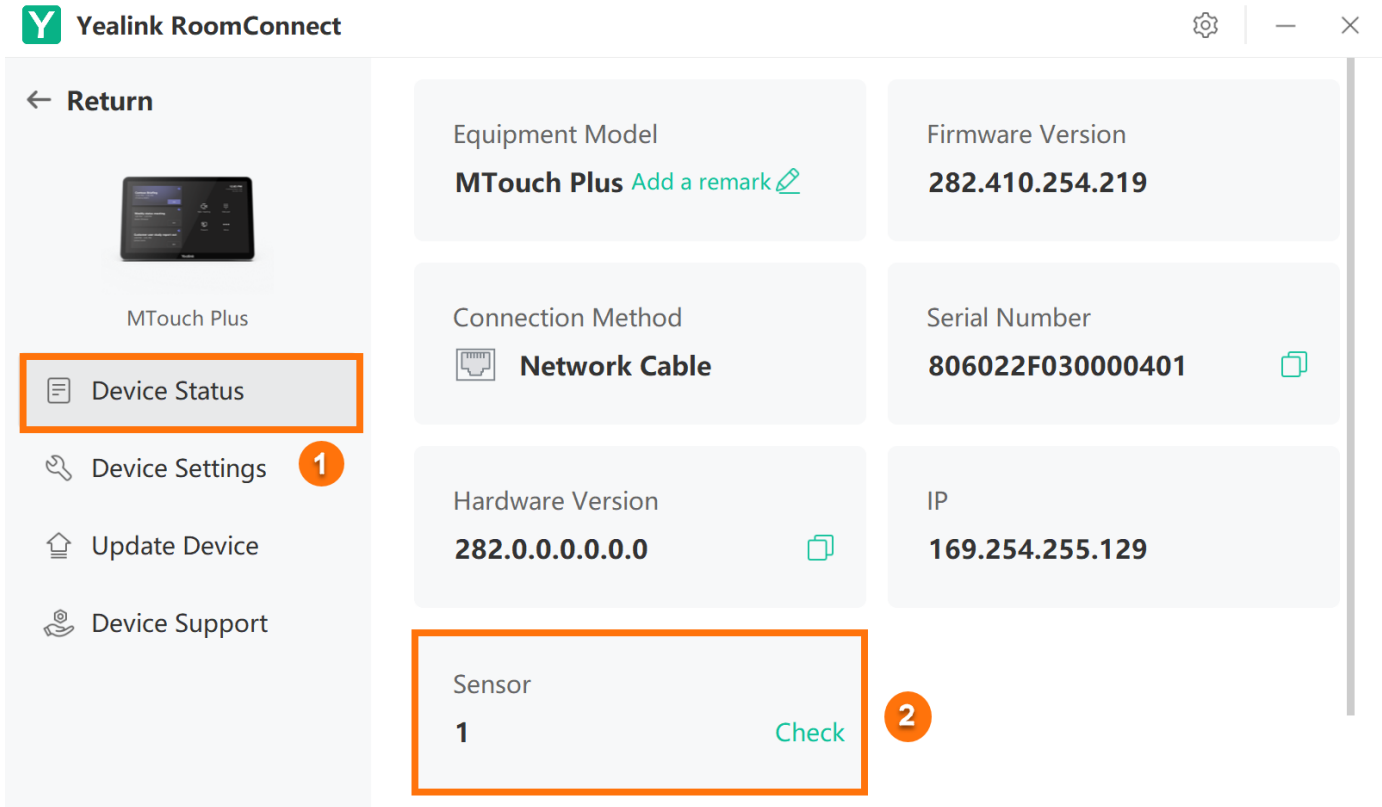

2. Pair MTouch Plus with Room Sensor.
3. Click **Energy Saving Plan**.
4. Set Work Time.

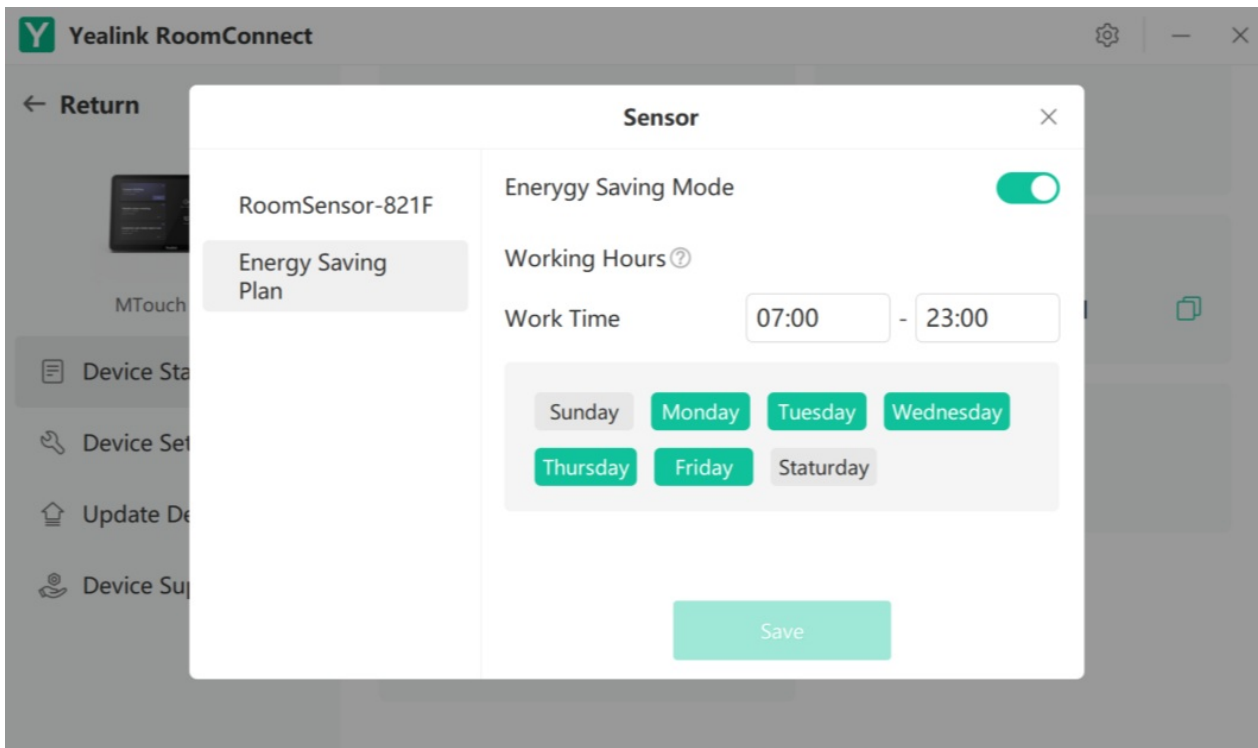

NOTE

The energy-saving mode is enabled by default. If specific working hours are not configured, default time settings are provided.

Energy Saving Mode

During non-working hours, the Room Sensor enters an ultra-low power mode, maintaining essential Bluetooth connectivity only, ensuring it can still receive commands and initiate operations.

MTouch II

Introduction

The MTouch II touch panel adopts a multi-functional design concept, and you can easily control calls, cameras, share screens and other functions. At the same time, MTouch II has a built-in human motion sensor. The conferencing system can automatically wake up when you enter the meeting room, and you can start the meeting immediately.

MTouch II Compatibility

For the MTouch II compatible devices, please refer to [Teams Room Accessories Compatibility Lists](#).

How to Use

Installation

Please refer to: [Installation](#).

Connect MTouch II

By connecting the VCH port of MTouch II and the VCH port of MCore (or the MTouch II port of MCore Pro) using an Ethernet cable, you can easily control features such as call control, camera control, and content sharing using MTouch II as a touch panel.

Content Sharing

You can also pair MTouch II with the WPP20 Wireless Presentation Pod for wireless content sharing. For more information, please refer to [Share Content via WPP20](#).

Hardware Interface

Please refer to: [Hardware Introduction](#).

LED Indicator

Please refer to: [LED Indicator](#).

Update MTouch II

After connecting the MTouch to the MVC device, it will automatically obtain the ROM package from the MVC device to update.

You can also manually update through the Yealink Device Management Platform. For more information, please refer to [Firmware Update](#).

FAQ

[How do I disable the Human Motion Sensor?](#)

[Can CTP18 be connected to MCore? Can CTP18 be used with MVC?](#)

[Can the MTouchII replace the CTP18 and connect it to A20?](#)

MVC BYOD-Extender

Introduction

Yealink MVC-BYOD-Extender supports the transformation between Microsoft Teams Rooms (MTR) and different types of UC platforms. Bring your device, plug the extender USB cable into the laptop, and start a video meeting whatever you want.

Users can enjoy the immersive video and audio experience with dedicated devices, easy MTouch II touch panel meeting controls and wireless sharing through the WPPP20 presentation pod. Deployment scenarios are as follows:

NOTE

Before using MVC BYOD-Extender, connect and deploy a complete set of MVC devices. If you do not connect to MCore, you cannot use BYOD mode normally.

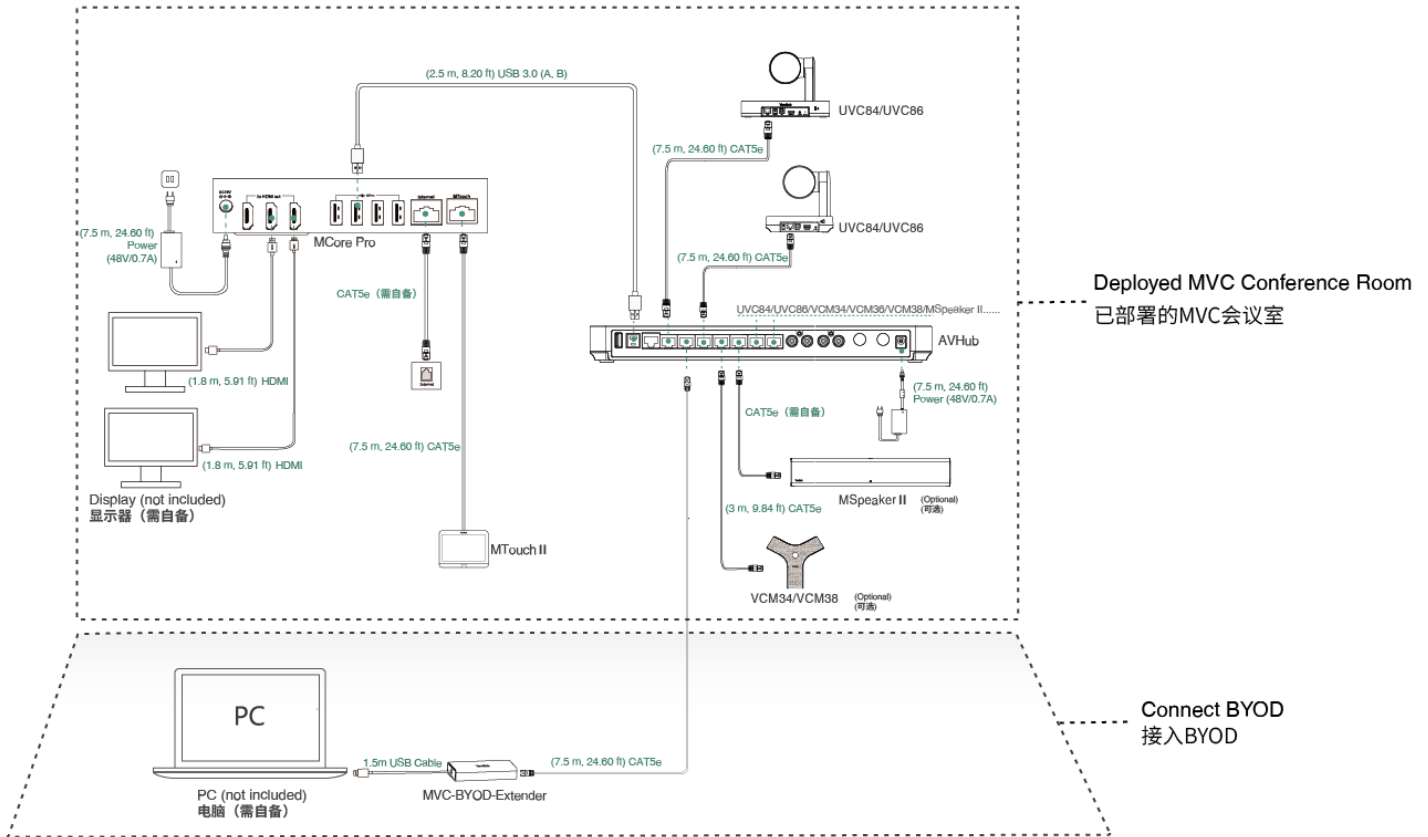

MVC BYOD-Extender Compatibility

Item	MVC960	MVC940	MVC860	MVC840	MVC660	MVC640-Wireless	MVC640-AI	MVC400	MVC320
BYOD-Extender	√	√	√	√	x	√	x	√	x

- The meeting rooms that are already connected to MSpeech, such as the MVC660 and MVC640-AI, do not support the use of the BYOD-Extender.
- The MVC BYOD-Extender does not support compatibility with other third-party devices.

How to Use

Installation

Installation

Connect Devices

NOTE

The UVC camera/AVHub needs to be connected to its own power supply or a PoE switch for power supply, and cannot be powered by BYOD-Extender.

Method 1: Connect to the VCH port of the UVC86/UVC84/UVC40 camera

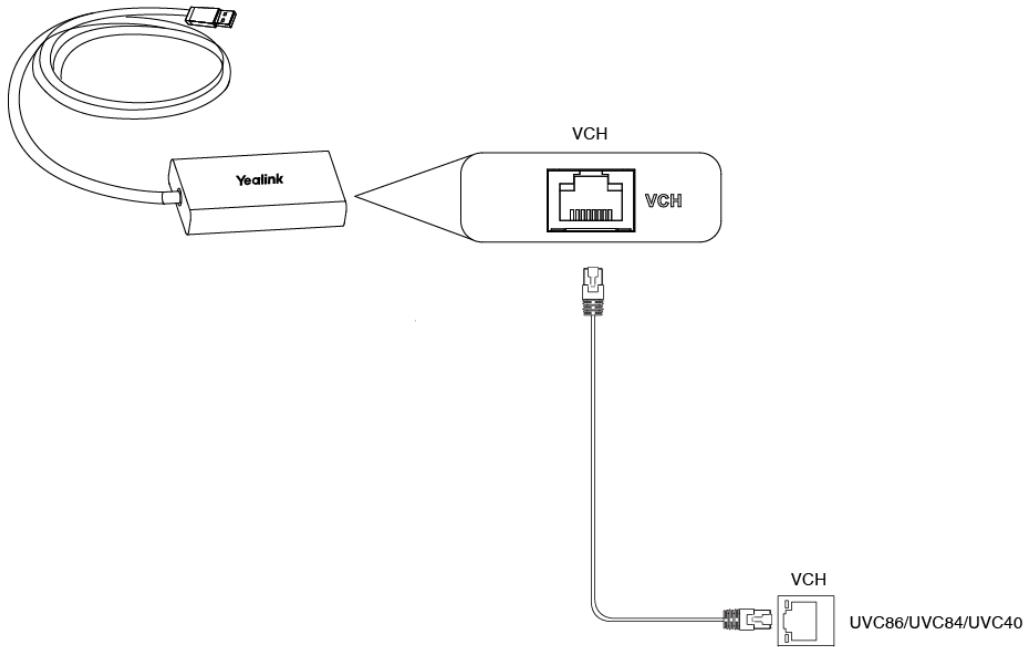

Method 2: Connect via PoE switch

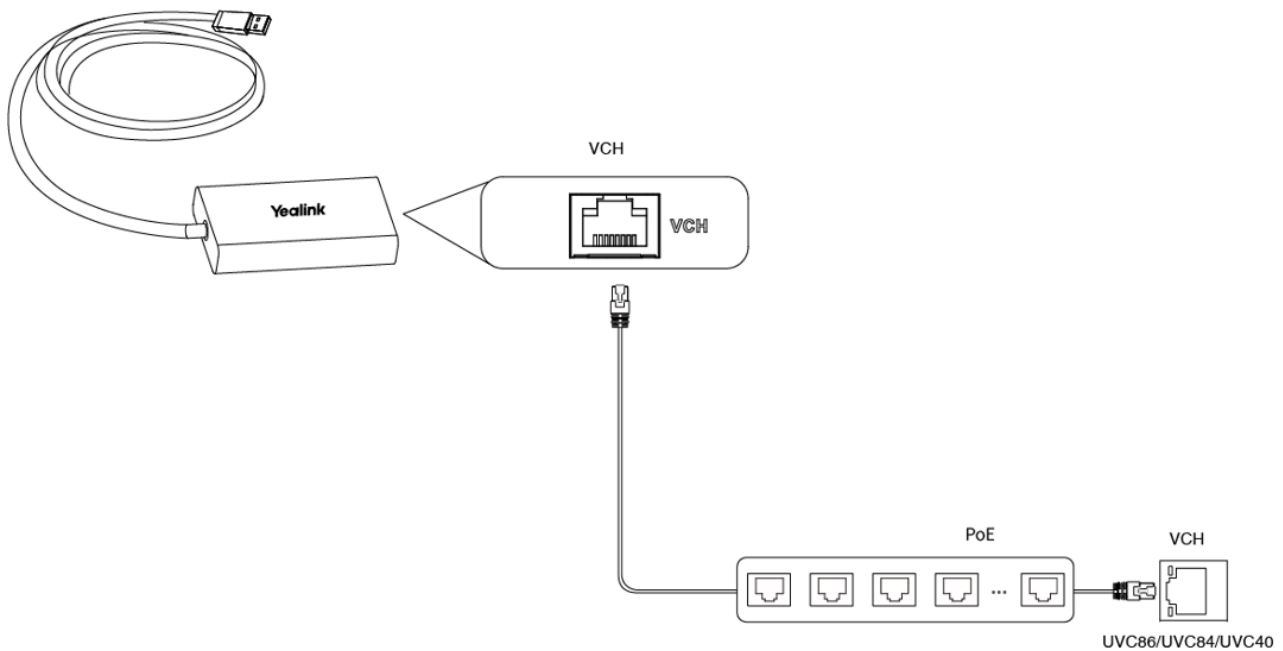

Method 3: Connect via AVHub

For specific connections, please refer to [AVHub](00. AVHub.md).

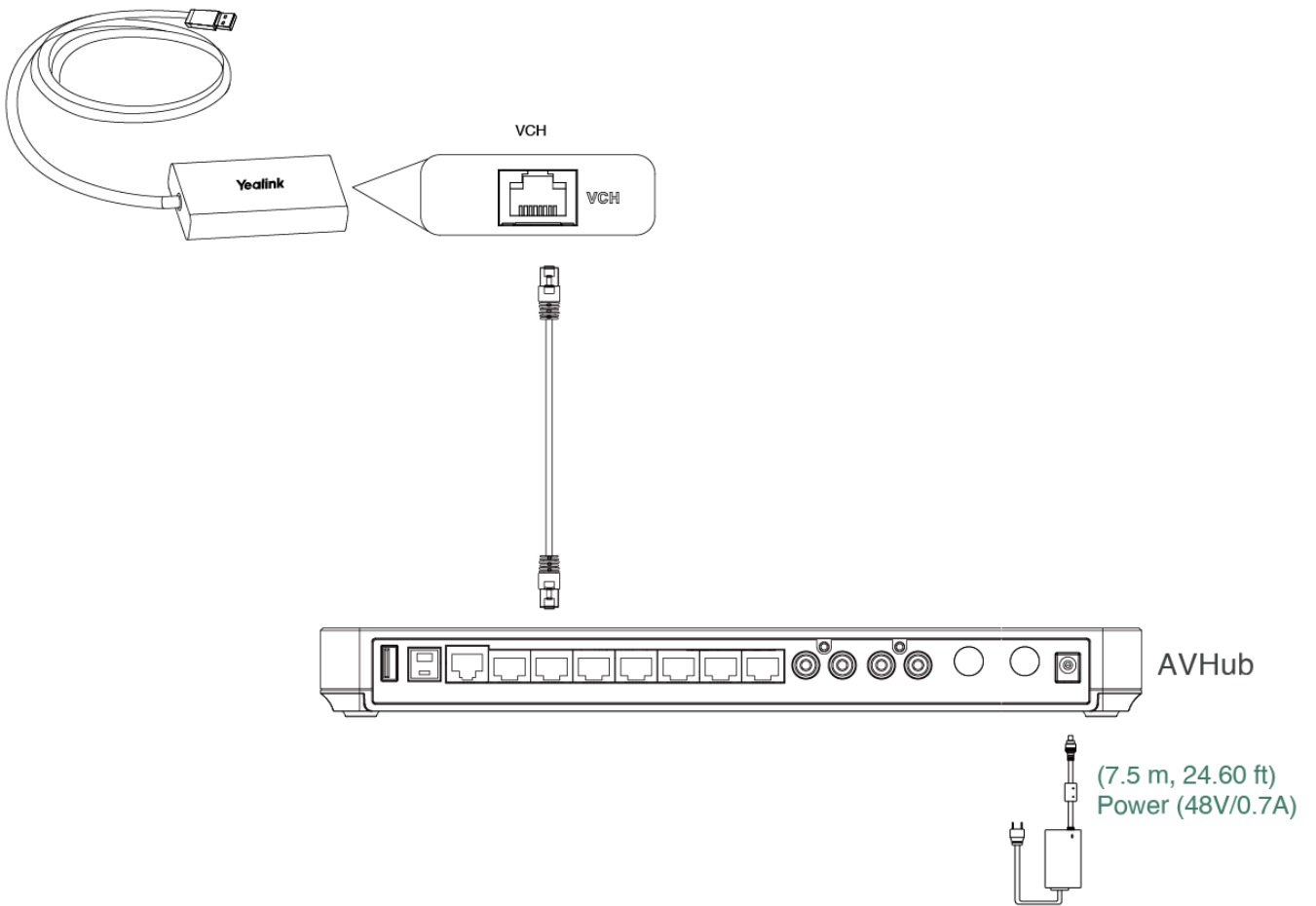

Connect to PC

Connect the USB port of the BYOD-Extender to your PC, and it will automatically enter BYOD mode. When you start a video meeting on your PC, you can use the audio and video device in the meeting room.

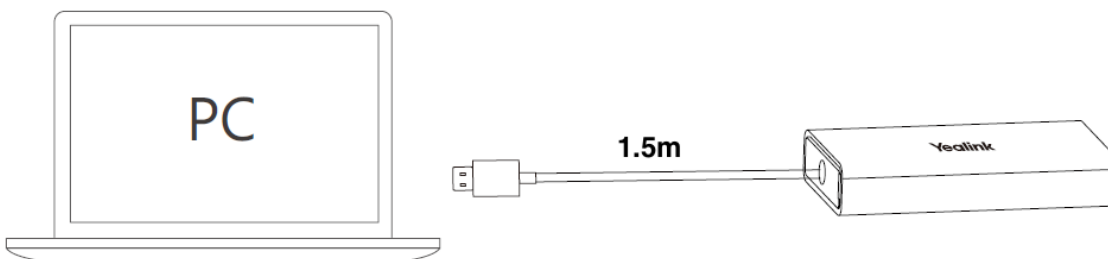

Connect HDMI Cable to Share Content

If you want to share a screen from your PC to your TV, connect an additional HDMI cable.

USB Connector

Introduction

Simply connect your personal computer to the camera and audio devices using the USB connector, and you can enter BYOD mode, enabling you to directly

utilize the professional audio equipment and camera in the meeting room.

Device Compatibility

For the USB Connector compatible devices, please refer to [Teams Room Accessories Compatibility Lists](#).

Installation

For more information, please refer to [Installation](#).

Hardware Instruction

For more information, please refer to [Hardware Instruction](#).

How to Use

You can connect the USB Connector to a PC via the USB-A or USB-C port.

1. Connect to PC via USB-A Port

The USB-A port cannot transmit video, so you need to connect the PC and the display via the HDMI cable to share the PC's contents with the display.

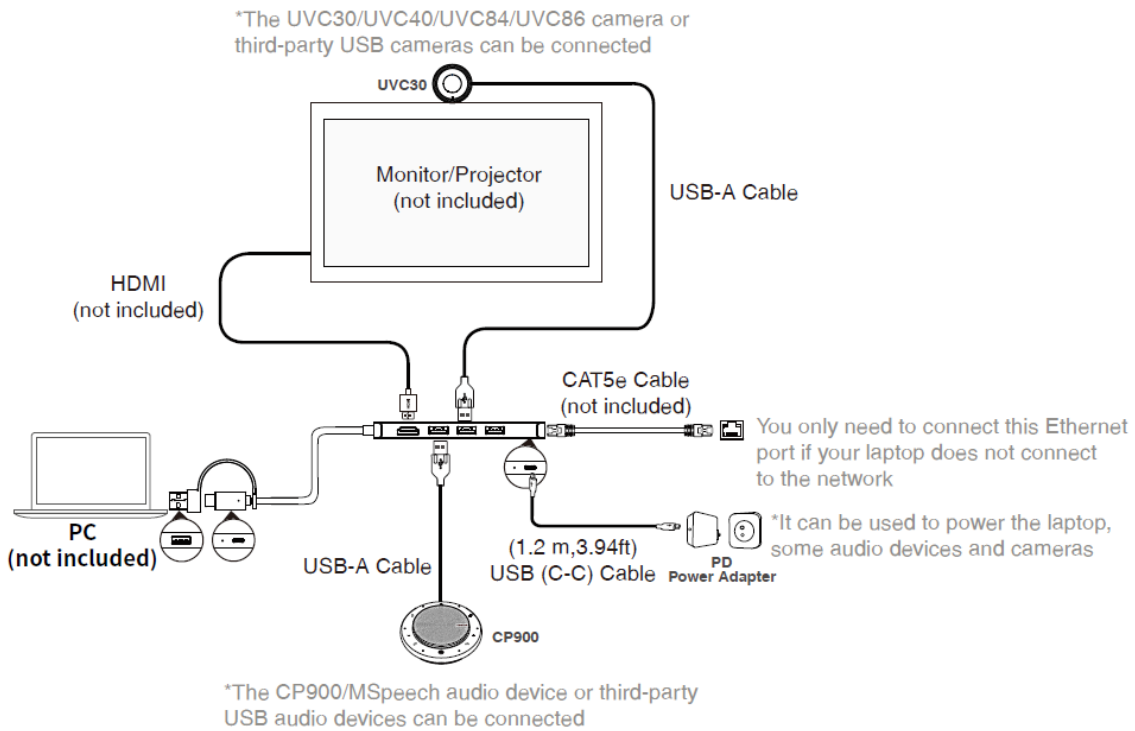

2. Connect to PC via USB-C Port

The USB-C port cannot transmit video, so you need to connect the USB Connector and the display via the HDMI cable to share the PC's contents with the display.

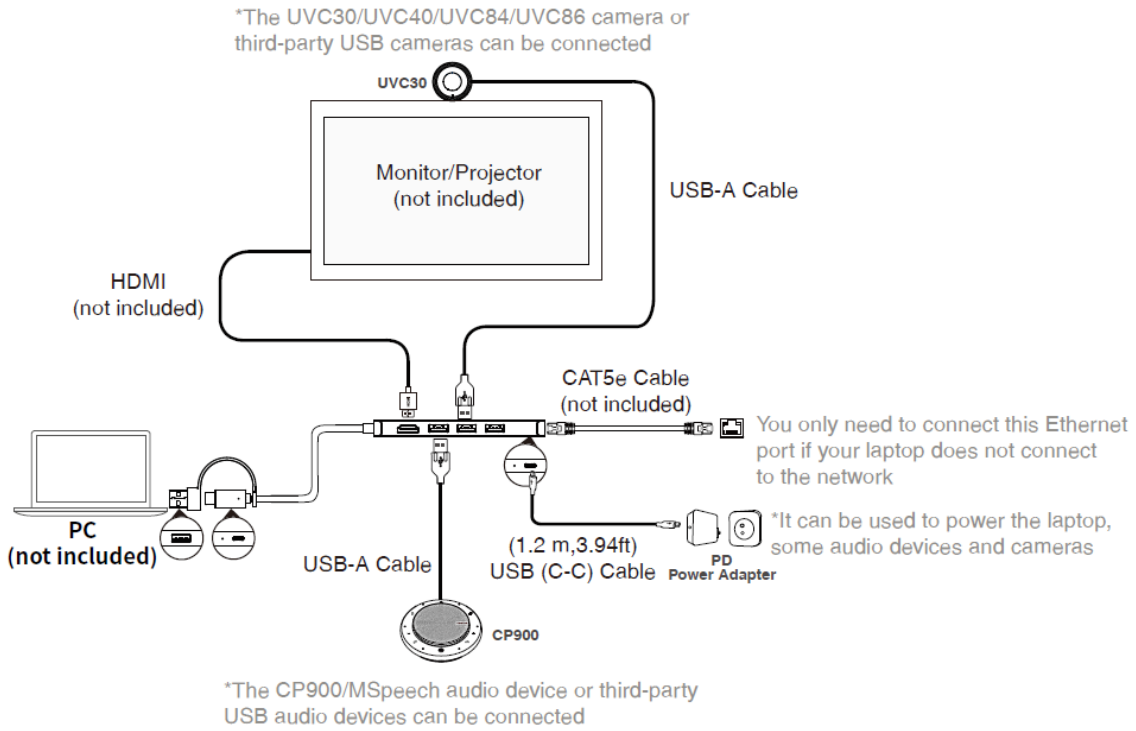

TIP

We recommend using a stable 1.8 m HDMI cable with a magnetic ring to connect the monitor or projector. You need to connect an external power supply to the camera if the camera has a power interface. Otherwise, the camera cannot be powered on.

BYOD-BOX

Installation

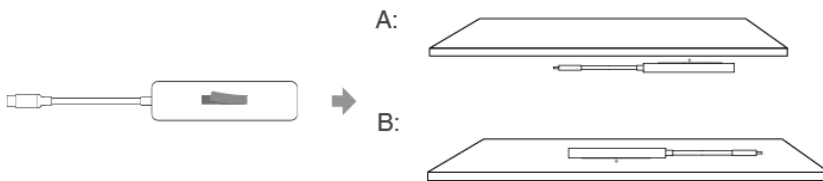

Hardware Instruction

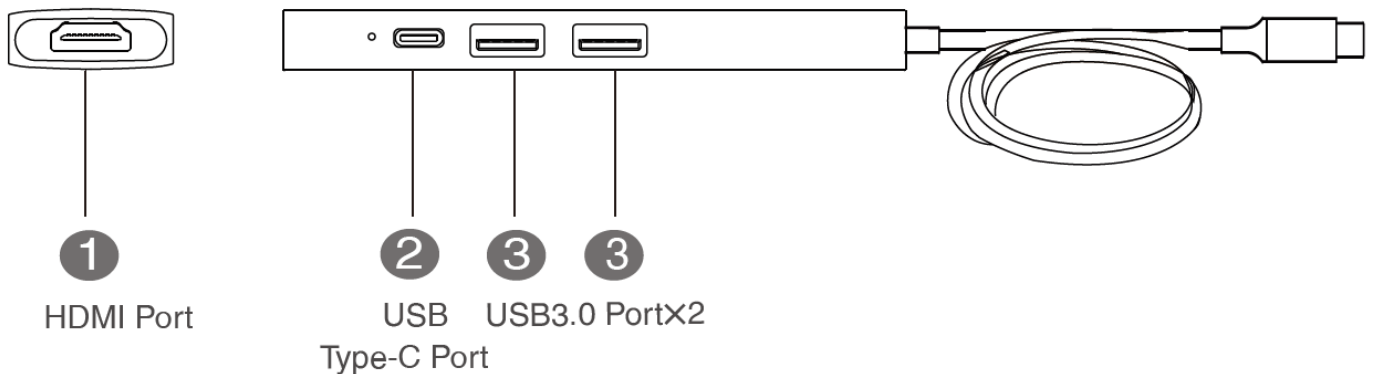

How to Use

For more information, please refer to [Connection](#).

USB to CAT Extender

Introduction

The USB to CAT extension cable is suitable for extending the connection between USB peripherals and MCore. It can also be used as an adapter for MTouch II to connect to a third-party mini-PC.

How to Use

For more information, please refer to [USB Extender](#).

VCR20 Remote Control

Introduction

NOTE

- Different versions of the VCR20 remote control can control different devices. For more information, please refer to [VCR20 Remote Control Compatibility](#).
- VCR20 uses AAA batteries (1.5V).

How to Use

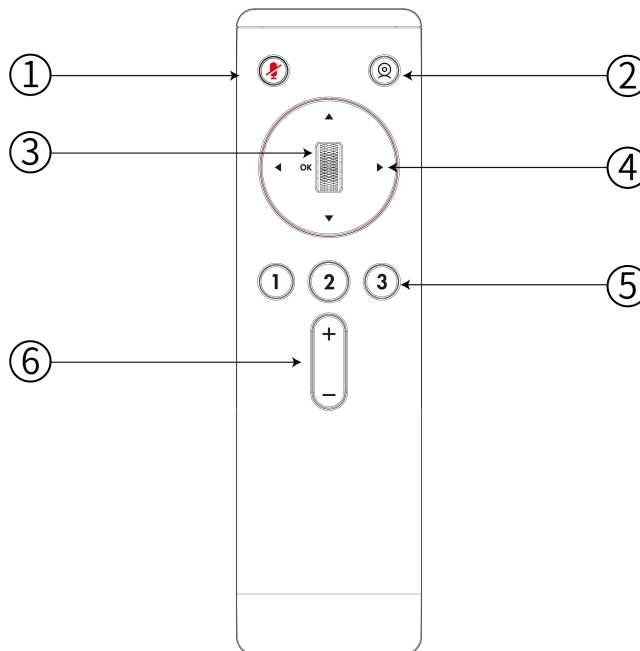

No.	Port Name	Description
1	Mute Key	Mute or unmute the microphone.

2	Tracking Feature Key	<ul style="list-style-type: none"> · For UVC40: Press and hold the Tracking Feature key to select tracking mode (Auto Framing, Speaker Tracking and Off). · For UVC84/UVC80/UVC50: Press and hold the Tracking Feature key to select tracking mode (Auto Framing and Off). · For UVC86: Press and hold the Tracking Feature key to select tracking mode (Auto Framing, Speaker Tracking, Presentation Tracking and Off).
3	OK Key	<ul style="list-style-type: none"> · Swipe up to zoom in the camera image. · Swipe down to zoom out the camera image. · Press OK to confirm.
4	Navigation Key	Pan and tilt the camera to adjust the viewing angle.
5	1/ 1/ 3 key	<ul style="list-style-type: none"> · Press and hold the number key to add/update the preset position. · Press the number key to apply for the preset position.
6	Volume Key	Turn up/down the volume.

FAQ

Which cameras can be controlled by different versions of VCR20?

Can not control UVC40 camera with VCR20 remote control when not in a meeting?

Single & Dual Display

Single and Dual Layouts

Introduction

We recommend connecting at least one external display to the MCore/Mini-PC to enjoy the video and content sharing in the meeting fully. If you connect two external displays and [Enable Dual Monitor Mode](#), the second screen will display the shared content in full screen.

Single Screen Layouts

The following introduces the default layout when you connect two displays.

Only Video Calls

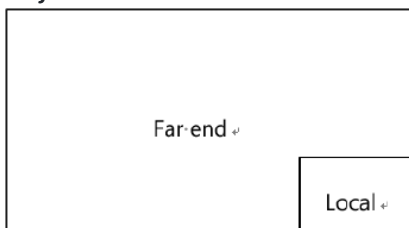

Video Calls with a Presentation

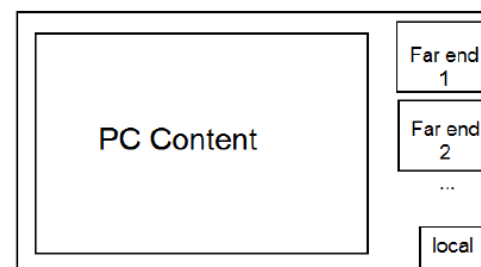

Dual Screen Layouts

The following introduces the default layout when you connect two displays.

The PC content is displayed in a large window, and other participants are displayed in a small windows beside the PC content. The second screen displays content in full screen. The second screen will not display content when no content is shared during the call/meeting.

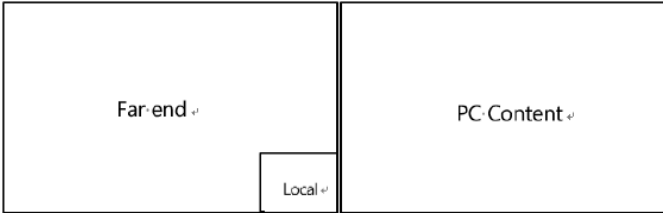

Enable Dual Monitor Mode

Introduction

Before using two external display devices, you must first enable the dual monitor mode. If you plug in two displays when dual monitor mode is not enabled, only one monitor will display content.

How to Use

Enable Dual Monitor Mode

You need to switch the system to Microsoft Teams mode (For more information, please refer to [Switch Account](#)).

1. Select **More > Setting** (default password: sfb).
2. Select **Device** to enable **Dual Monitor Mode**.
3. Select **Save and exit**.

You can select **Swap Screens** to switch the display of both screens.

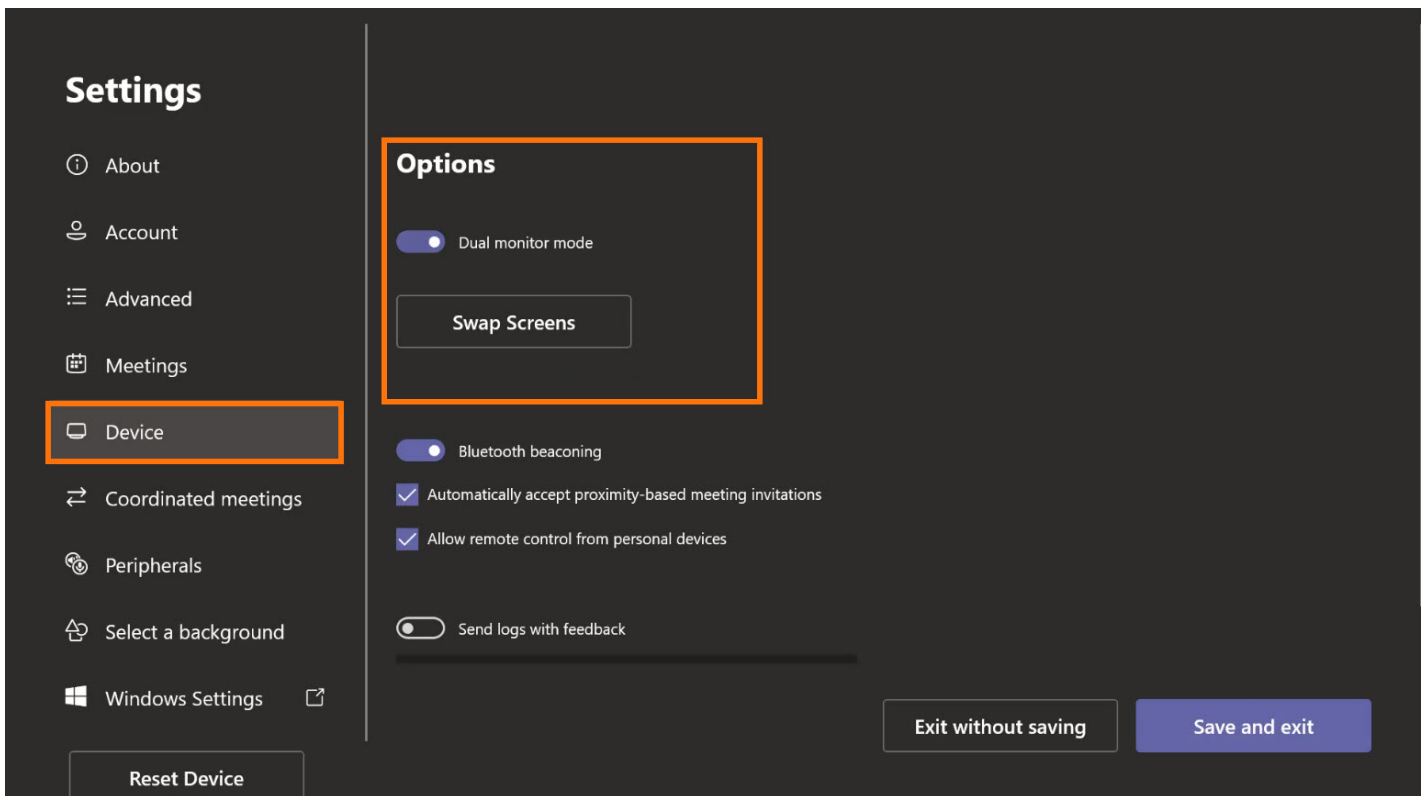

FAQ



Why can't the dual displays be used after the MVC device joins the Third-party Zoom meeting?

The way to join a third-party Zoom meeting is through the web user interface, so dual displays cannot be used in third-party meetings.

Can I set dual screens as duplicate screens? How do I set the extended screen as a duplicate screen?

In the Microsoft Teams mode, the dual displays default to an extended display and cannot be set as a duplicate display. Please refer to [Single and Dual Layouts](#) for the display layout.

In the Windows mode, the dual displays default to an extended screen. You can change the dual displays to a duplicate screen as follows:

1. You need to switch the system to Microsoft Teams mode (For more information, please refer to [Switch Account](#)).
2. Go to  >  > **System** > Display > Multiple displays to select **Duplicate these displays** or **Extend these displays**.

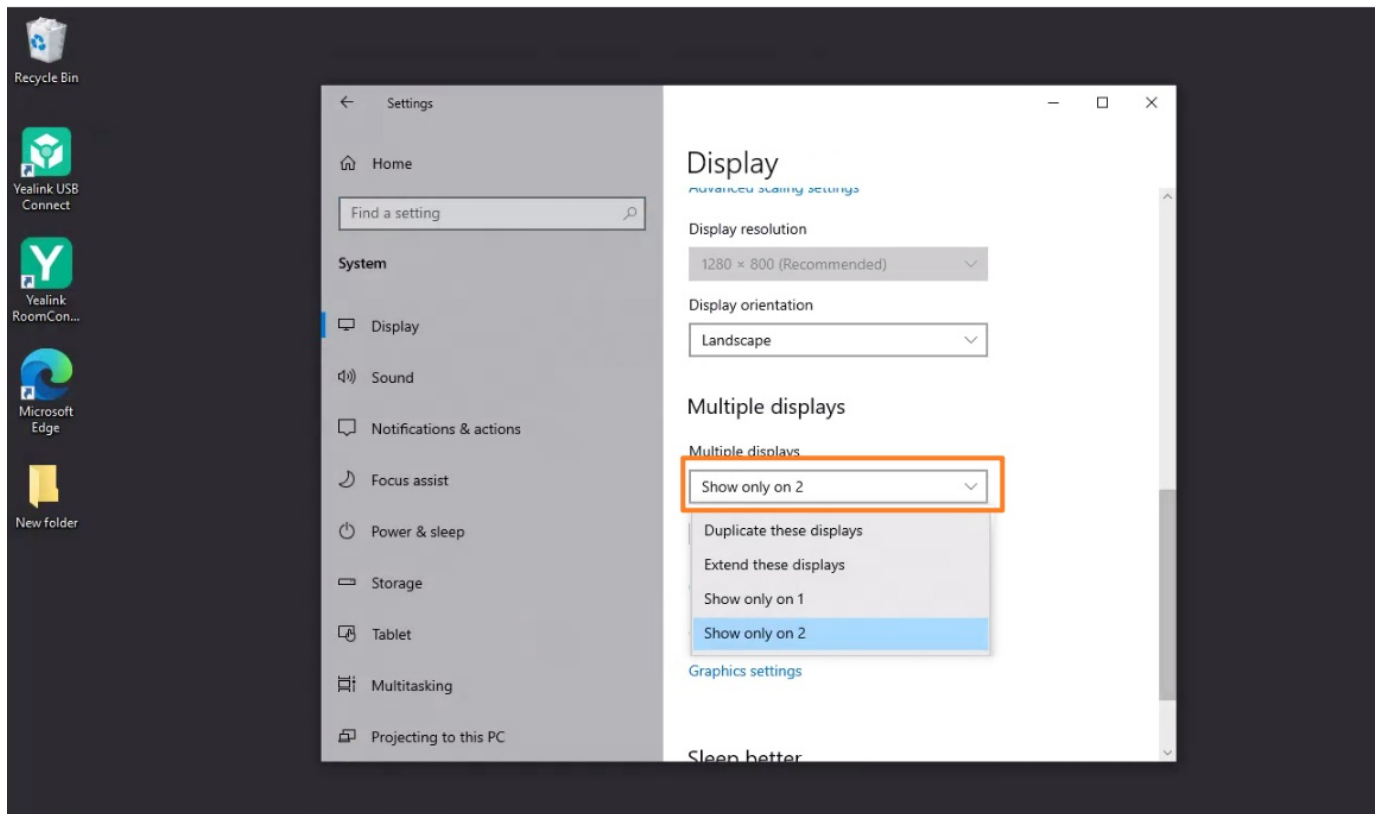

BYOD Mode

BYOD Mode

Introduction

BYOD, i.e., Bring Your Own Device. In BYOD mode, you can use the audio and video device of the MVC conference system as a peripheral for third-party conferences. When holding a meeting on the PC, you can use the camera, speaker, and microphone of MVC and display the PC content on the screen connected to MVC.

How to Use

1. Connect BYOD

To use the BYOD mode, you need to purchase MVC BYOD-Extender or USB Connector to connect your PC to the MVC conference system.

- MVC BYOD-Extender: Connect the PC with the deployed MVC conference system to enter the BYOD mode. A fully deployed MVC conferencing system is required. If only audio and video devices are connected, and MCore is not deployed, it cannot be used in BYOD mode. For more information, please refer to [MVC BYOD-Extender](#).
- USB Connector: Connect your PC directly to your audio and video device to enter BYOD mode. For more information, please refer to [USB Connector](#).

FAQ

Do I need an HDMI cable to connect to the display in BYOD mode?

Yes, the PC can use the audio and video devices of the conference room system in BYOD mode. If you want to share the content of the PC with the display, you also need to connect the display with an HDMI cable.

- When entering BYOD with MVC BYOD-Extender:

When using MVC BYOD-Extender, you need to use an HDMI cable to connect the PC to the MTouch II and the display to display the contents of the PC. For more information, please refer to [Share Content via Cable](#).

- When entering BYOD with USB Connector:

If you use the USB-A port to connect to a PC: the USB-A port cannot transmit video, so you need to connect the PC and the display via the HDMI cable to share the PC's contents with the display. For the specific connection method, please refer to [MVC BYOD-Extender](#).

If you use the USB-C port to connect to a PC: the USB-C port cannot transmit video, so you need to connect the USB Connector and the display via the HDMI cable to share the PC's contents with the display. For the specific connection method, please refer to [USB Connector](#).

WPP30 Supports Wireless BYOD

Introduction

When conducting a meeting using a personal computer and utilizing the audio and video equipment within the conference room, you can enable **Wireless BYOD Mode** on UVC86, pair the WPP30 with the MTouch Plus (or MTouch E2), UVC 86, and external audio devices. After a successful pairing, connect the WPP30 to your personal computer and select the **BYOD Mode** to enter the wireless device mode, thus enhancing your meeting's audio and video experience.

Before You Begin

MTouch Plus is supported in 282.432.0.5 and later versions.

WPP30 is supported in 270.352.0.75 and later versions.

How to Use

1. You can directly use MTouch for operations or perform operations remotely. For remote management, please refer to [Remote Control](#).
2. Switch to **Windows mode**. For instructions on how to switch, please refer to [Switch Account](#).

Connect & Enter Device Mode

1. Connect the UVC86 Camera and MTouch Plus, MTouch E2 to the MCore Pro.

- 2. Enable the Wireless BYOD Mode on Yealink RoomConnect.
Click **UVC Device** > **Device Settings** > **Advanced Settings**.

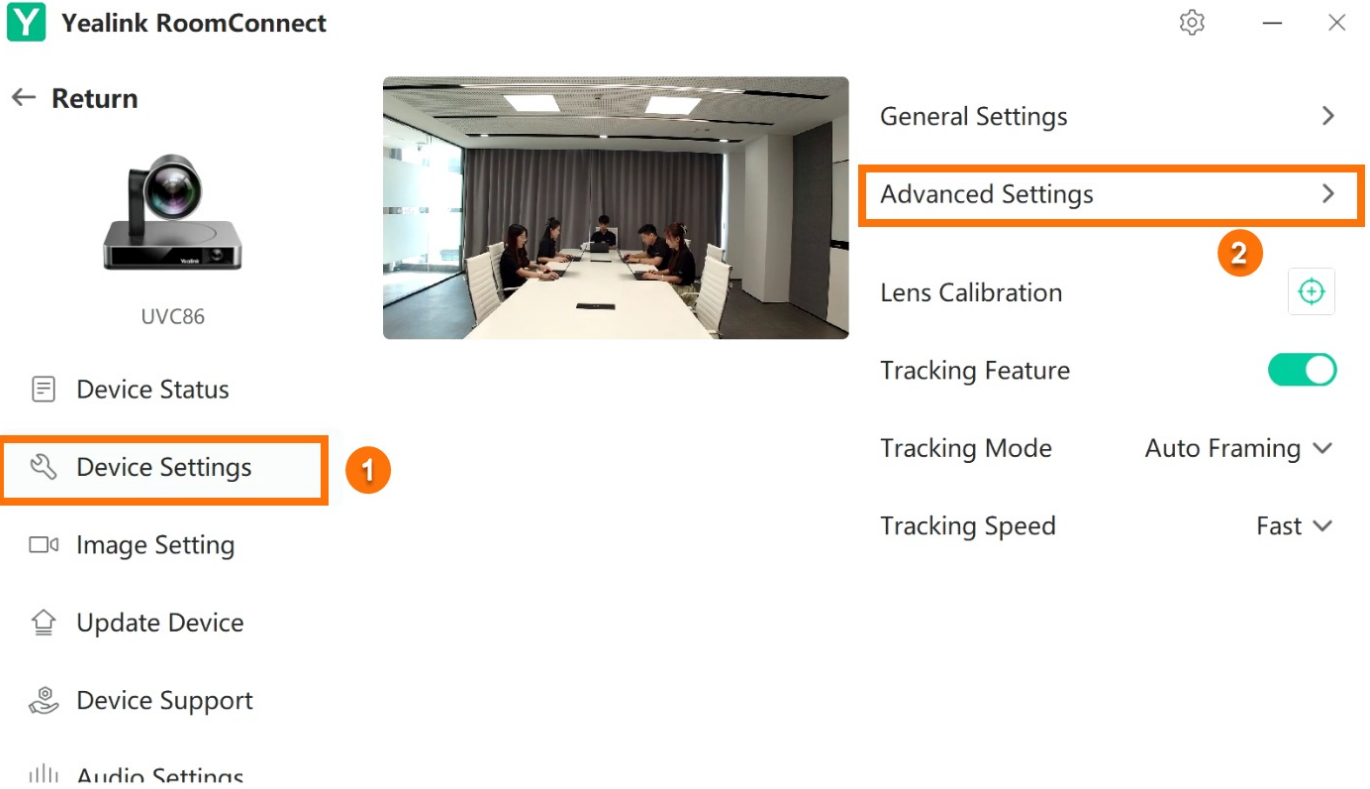

- Click **Wireless BYOD Mode**

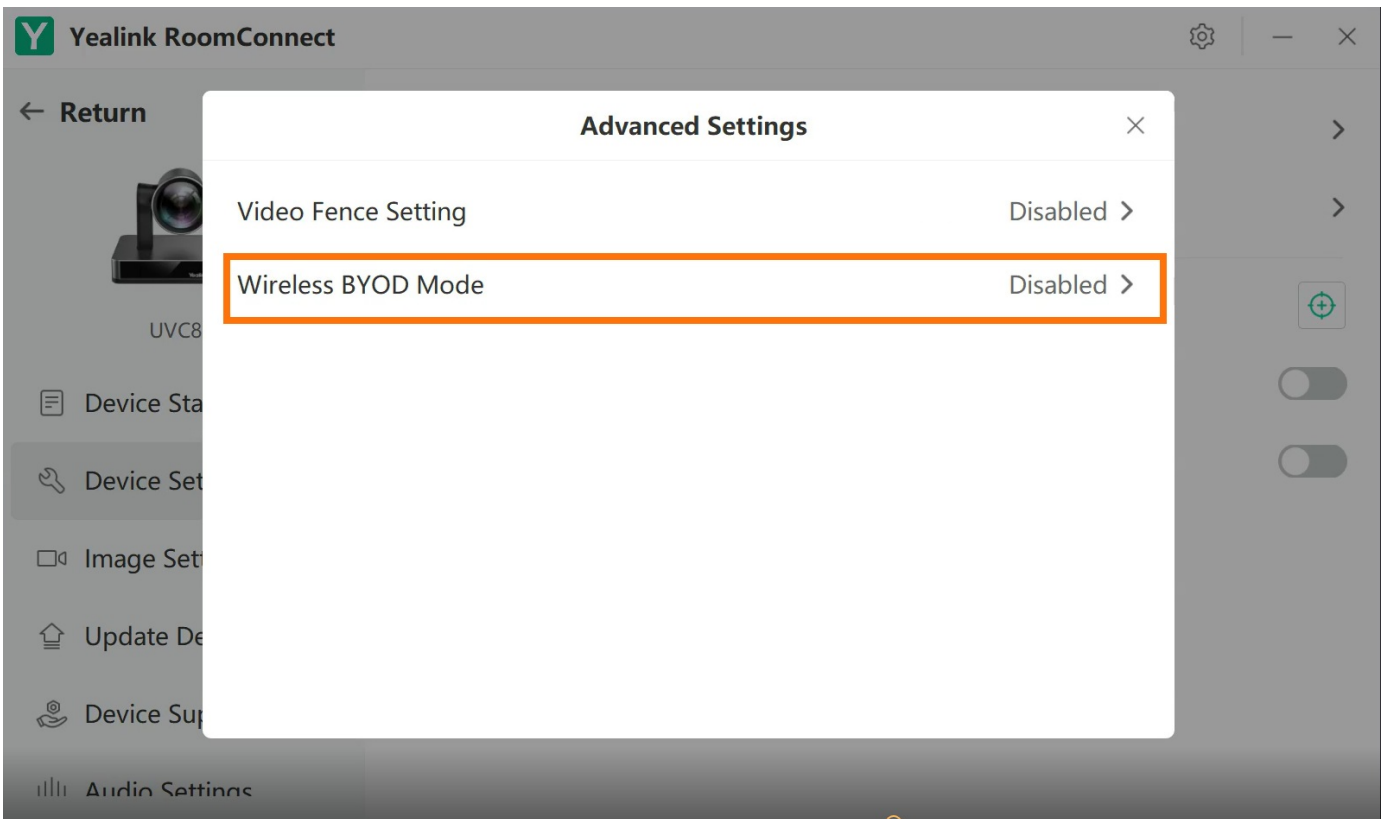

- Enable **Wireless BYOD Status**

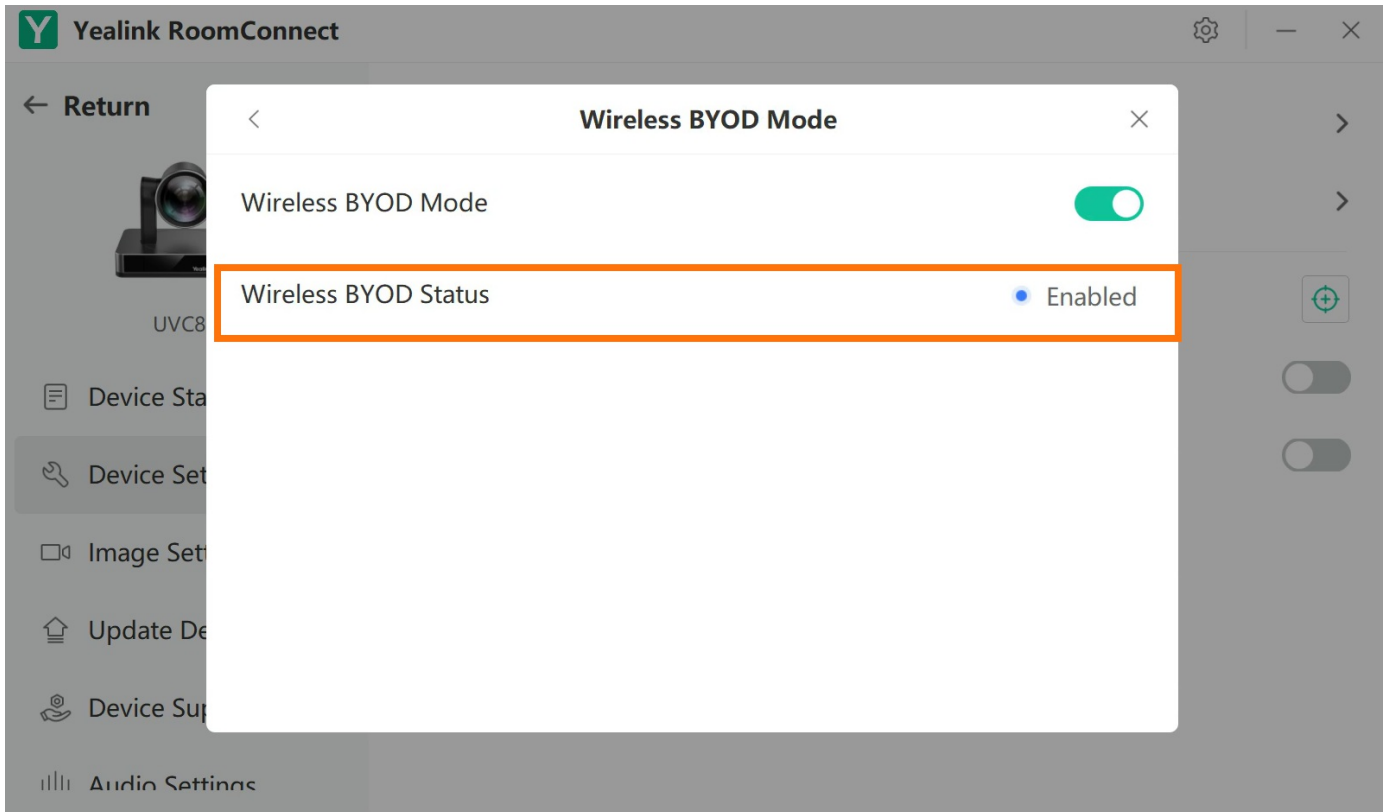

3. Insert the WPP30 into the USB-A port of MTouch Plus. The breathing status green light on the WPP30 indicates a successful pairing with MTouch Plus.



NOTE

The USB-A port used is located on the side of the MTouch Plus.

4. Insert the WPP30 into the USB-C port of PC, and click **BYOD Mode** on **Yealink Wireless Presentation Pod**. You will have two ways to enter the wireless BYOD mode:

- Click **BYOD Mode > Press to share**.
- Press the WPP30 button for 4 seconds.

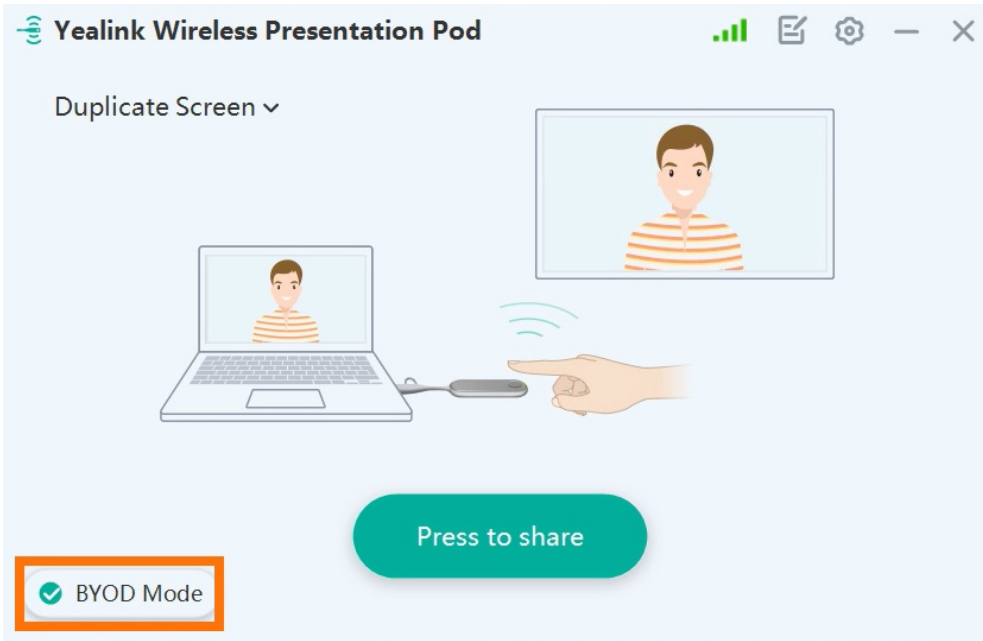

NOTE

If **BYOD Mode** does not appear in the popup window of the **Yealink Wireless Presentation Pod**, please unplug and plug in the WPP30 again. The system will prompt you for an upgrade.

5. If audio devices are connected with UVC device, click to select **Yealink Room Audio** in the input and output device settings under Sound settings.

- Select in Windows:

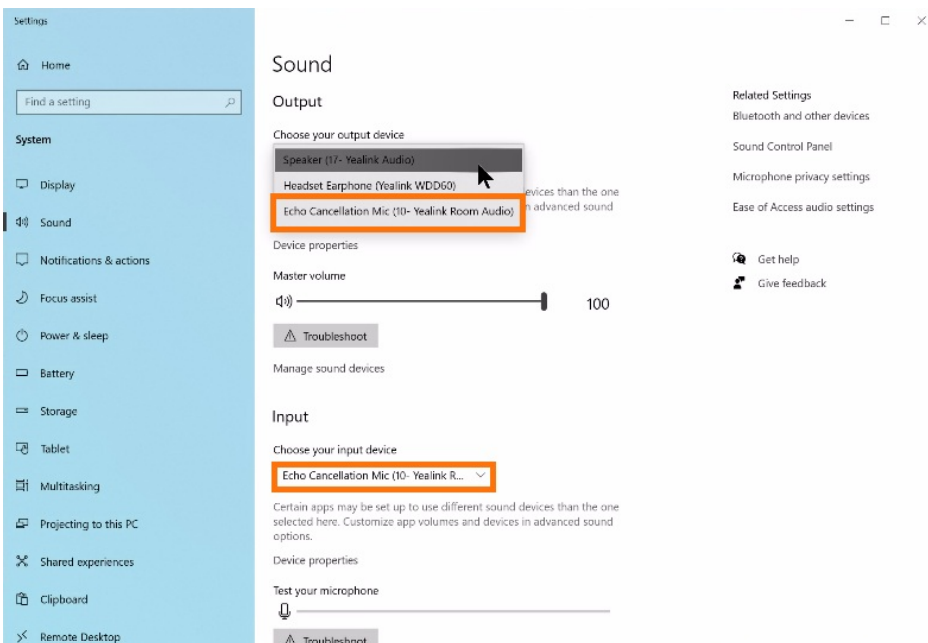

- Select in Google Meet:

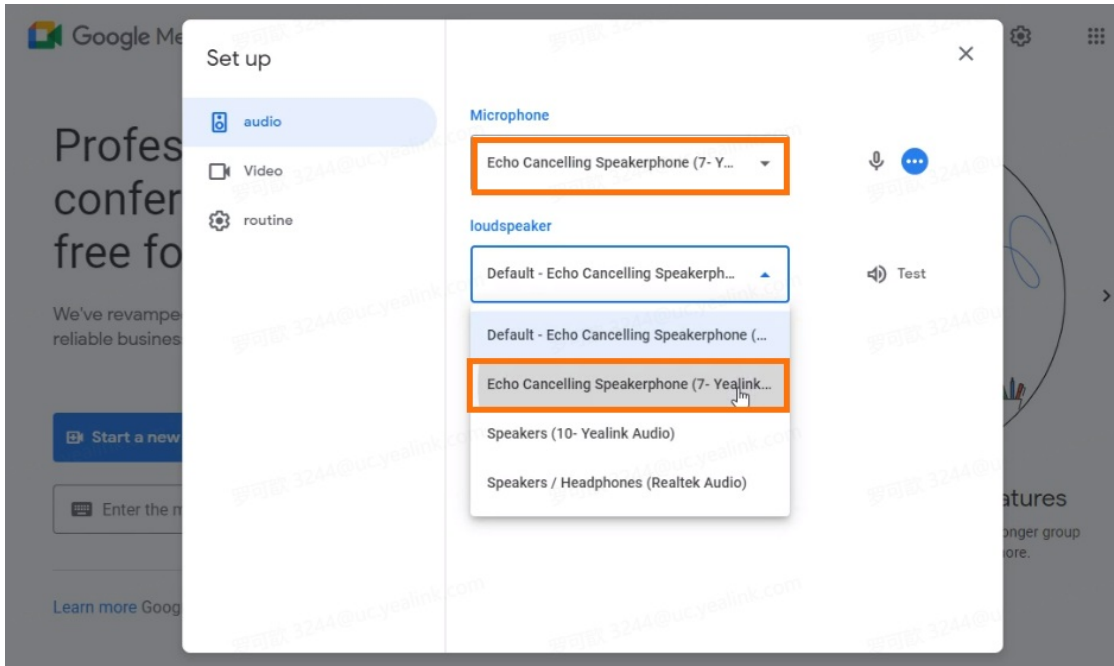

Exiting Device Mode

Choose one of the following methods:

- Disconnect the WPP30.
- Click **BYOD Mode** again on **Yealink Wireless Presentation Pod**.

CEC

CEC

Introduction

The CEC functionality in MVC refers to the synchronized wake-up feature between the MVC and the TV display.

The MTouchII device is equipped with a presence sensor, which automatically wakes up the MTouchII and synchronizes the wake-up of the TV display when someone enters the meeting room or approaches the MTouchII.

If your meeting room has glass partitions, the presence sensor may also detect movement outside the meeting room, resulting in the automatic wake-up of the MTouchII and TV.

However, the MVC currently does not support scenarios where the MTouchII is awakened by waking up the TV or where the MTouchII and TV enter sleep mode synchronously.

How to Use

The CEC feature is supported by default. If your display uses CEC, the device automatically wakes up when you enter the meeting room. However, scenarios such as waking up the TV to wake up MTouchII and MTouchII and the TV entering sleep synchronously are not supported.

FAQ

Does MVC support the CEC feature? How do I enable or disable CEC for MVC?